

ECHO®

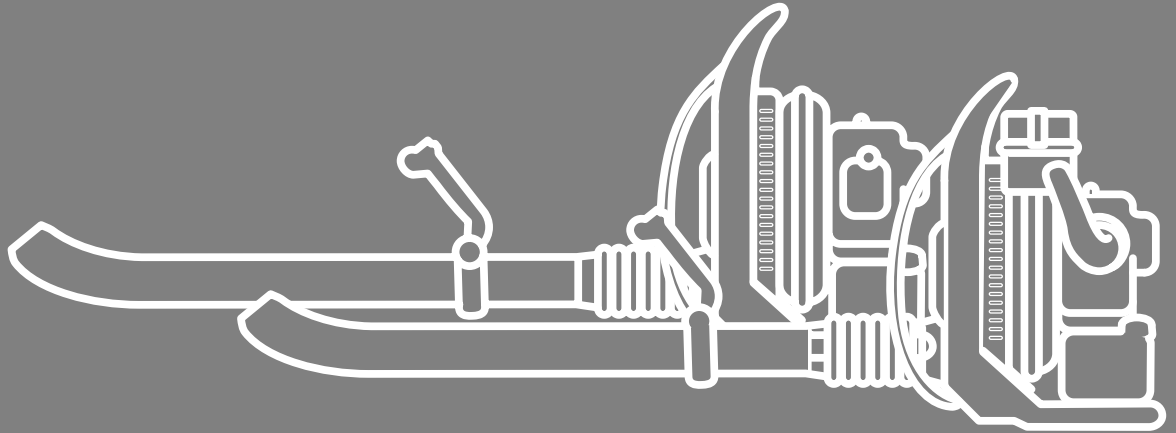

SERVICE MANUAL

PB-650
PB-750



REVISED JUNE 2004

Ord. No. 403-12

INTRODUCTION

This service manual contains information for service and maintenance of **ECHO POWER BLOWER**, model **PB-650 (Serial Number up to 35999999) and PB-750 (Serial Number up to 35999999)**.

For systematic diagnosis, to avoid extra work and time loss, please refer to “Troubleshooting guide” that describes problems, testings, remedies and references. We recommend you make use of Operator’s Manual and Parts Catalog together with this manual when servicing.

We are constantly working on technical improvement of our products. For this reason, technical data, equipment and design are subject to change without notice. All specifications, illustrations and directions in this manual are based on the latest products information available at the time of publication.

	Page		Page
1 SERVICE INFORMATION	2	5-2 Removing handle	26
1-1 Specifications	2	5-3 Replacing throttle wire and switch	27
1-2 Technical data	3	5-4 Adjusting throttle control lever friction	27
1-3 Torque limits	4	5-5 Assembling handle	27
1-4 Special repairing materials	5	5-6 Positioning throttle wire and tube	27
1-5 Service limits	6	5-7 Adjusting throttle wire	28
1-6 Special tools	7	5-8 (Option) Assembling static protection kit	28
2 STARTER SYSTEM	8	6 BACKPACK FRAME	29
2-1 Removing starter drum and rope	9	6-1 Replacing back cushion and harness	29
2-2 Replacing rope guide	10	6-2 Removing backpack frame	30
2-3 Installing rewind spring	10	6-3 Checking rubber cushions	30
2-4 Installing starter drum and rope	11		
2-5 Increasing rope tension	12	7 BLOWER SYSTEM	31
2-6 Replacing starter pawl	12	7-1 Replacing elbow blowing pipe	31
		7-2 Replacing fan case grid	32
3 IGNITION SYSTEM	13	7-3 Separating fan case and engine	32
3-1 Troubleshooting guide	13	7-4 Assembling fan and fan case	33
3-2 Testing spark	14	7-5 Assembling engine unit on backpack frame	34
3-3 Checking spark plug	14		
3-4 Replacing spark plug cap and coil	15	8 ENGINE	35
3-5 Checking coil resistance	15	8-1 Testing cylinder compression	35
3-6 Checking ignition switch	16	8-2 Cleaning cooling air passage	36
3-7 Checking flywheel magnets	16	8-3 Checking muffler and exhaust port of cylinder	36
3-8 Replacing ignition coil	16	8-4 Testing crankcase and cylinder sealings	37
3-9 Setting pole shoe air gaps	17	8-5 Checking cylinder	38
3-10 Assembling dust cover and lead	17	8-6 Removing flywheel	38
		8-7 Checking woodruff key for flywheel	38
4 FUEL SYSTEM	18	8-8 Installing flywheel	39
4-1 Cleaning air filter	19	8-9 Checking piston and piston ring	39
4-2 Checking fuel cap and strainer	19	8-10 Disassembling crankcase	40
4-3 Adjusting carburetor	20	8-11 Removing main ball bearing and oil seal	40
4-4 Testing carburetor	21	8-12 Assembling main ball bearing	41
4-5 Checking fuel tank and vent	22	8-13 Assembling crankshaft and crankcase	41
4-6 Replacing fuel line and grommet	22	8-14 Assembling oil seal	42
4-7 Checking metering lever	23	8-15 Assembling piston rings on piston	42
4-8 Checking inlet needle valve	23	8-16 Installing piston	43
4-9 Checking diaphragm and others	24	8-17 Installing cylinder	43
4-10 Removing main jet	24		
4-11 Checking pulse passages	25	9 MAINTENANCE GUIDE	44
4-12 (Option) Assembling heavy duty air cleaner kit ..	25	9-1 Troubleshooting guide	44
		9-2 Service intervals	46
5 HANDLE AND CONTROL SYSTEM	26	9-3 Disassembly chart	47
5-1 Adjusting handle position	26		
		INDEX	48

1 SERVICE INFORMATION

1-1 Specifications

Model		PB-650	PB-750
Dimensions	Length*	mm(in)	375 (14.8)
	Width*	mm(in)	470 (18.5)
	Height*	mm(in)	527 (20.8)
Dry weight**		kg(lb)	10.7 (23.6) 11.4 (25.1)
Engine	Type	KIORITZ, air-cooled, two-stroke, single cylinder	
	Rotation	Counterclockwise as viewed from the output end	
	Displacement	cm ³ (in ³)	63.3 (3.863)
	Bore	mm(in)	48.0 (1.89s)
	Stroke	mm(in)	35.0 (1.38)
	Compression ratio	6.3	
Carburetor	Type	Diaphragm, horizontal-draught, with primer (purge pump)	
	Model	Walbro WYK-150	Walbro WYK-179
Ignition	Type	CDI (Capacitor discharge ignition) system	
	Spark plug	BPM8Y	
Starter	Type	Automatic rewind	
	Rope diameter x length	mm(in)	3.5 x 1000 (9/64 x 39 1/2)
Fuel	Type	Premixed two-stroke fuel	
	Mixture ratio	50 : 1 (2 %)	
	Petrol	Minimum 89 octance petrol (RON)	
	Two-stroke air cooled engine oil	ISO-L-EGD (ISO/CD13738), JASO FC	
	Tank capacity	L (U.S.fl.oz.)	2.0 (67.64)
Throttle	Throttle control type	Trigger type with lock	
	Throttle lever location	Adjustable-tube mounted	
Blower	Fan type	Centrifugal, single stage	
	Max. air volume (with pipes)	m ³ /min (ft ³ /min)	17 (600.35)**
	Max. air velocity (with pipes)	m/s (mph)	97 (217)***
	Discharge ID	mm (in)	62 (2.441)

ID : Inner diameter.

* Without blower pipes.

** With straight pipes.

*** With taper pipe.

1-2 Technical data

Model		PB-650	PB-750
Engine			
Idling speed	r/min	2200 - 2800	
Wide open throttle speed	r/min	7000	
Compression pressure	MPa (kgf/cm ²) (psi)	0.8 (8.0) (115)	
Ignition system			
Spark plug gap	mm(in)	0.6 - 0.7 (0.024 - 0.028)	
Minimum secondary voltage at 1000 r/ min	kV	12	
Secondary coil resistance	kΩ	1.2 - 1.8	
Pole shoe air gaps	mm(in)	0.3 - 0.4 (0.012 - 0.016)	
Ignition timing	°BTDC	30	
Carburetor			
Venturi size	mm(in)	15.0 (0.591)	
Throttle bore	mm(in)	15.0 (0.591)	
Main jet		#58.5	#50
Idle adjust screw initial setting	turn in*	1 1/2	
Test Pressure, minimum	MPa (kgf/cm ²) (psi)	0.05 (0.5) (7.0)	
Metering lever height	mm (in)	1.5 (0.06) lower than diaphragm seat	

BTDC: Before top dead center.s

* Set idle speed screw to contact throttle plate before initial setting.

** Screw in idle mixture needle from initial thread engagement (at the point that the clicking sound is heard).

1-3 Torque limits

Descriptions	Size	kgf•cm	N•m	in•lbf	
Starter system	Starter pawl assembly	M 10	80 - 100	8 - 10	70 - 90
	Starter case	M 5***	35 - 50	3.5 - 5.0	30 - 45
Ignition system	Flywheel	M 10	200 - 240	20 - 24	175 - 210
	C.D.I module	M 5	60 - 100	6 - 10	50 - 90
Fuel system	Spark plug	M 14	150 - 170	15 - 17	130 - 150
	Carburetor	M 5	40 - 55	4.0 - 5.5	35 - 48
	Intake insulator	M 5	35 - 45	3.5 - 4.5	30 - 40
	Fuel tank	M 5	20 - 40	2 - 4	17 - 35
Engine	Crankcase	M 5	70 - 110	7 - 11	60 - 95
	Cylinder	M 5	70 - 110	7 - 11	60 - 95
	Engine plate	M 5*	20 - 40	2 - 4	17 - 35
	Engine mount	M 6	100 - 150	10 - 15	90 - 130
	Cylinder cover	M 5	40 - 55	4.0 - 5.5	35 - 48
	Engine cover	M 5**	20 - 40	2 - 4	17 - 35
	Muffler	M 6***	110 - 150	11 - 15	95 - 130
	Muffler bracket	M 5	70 - 110	7 - 11	60 - 95
	Muffler insulator	M 5*	20 - 40	2 - 4	17 - 35
Others	Fan	M 5	50 - 75	5.0 - 7.5	45 - 65
	Fan case	M 5**	40 - 55	4.0 - 5.5	35 - 48
	Blower grid	M 5**	20 - 40	2 - 4	17 - 35
	Cushion				
	Frame side	M 5***	20 - 40	2 - 4	17 - 35
	Fan case side				
	Top	M 5**	20 - 40	2 - 4	17 - 35
	Bottoms	M 5**	80 - 100	8 - 10	70 - 90
	Main pipe	M 5	20 - 40	2 - 4	17 - 35
	High tension lead clip	M 5**	40 - 50	4 - 5	35 - 45
	Harness fixture	M 5**	20 - 40	2 - 4	17 - 35
	Trigger bracket fixture†	M 5	20 - 30	2 - 3	17 - 26
Throttle lever††	M 6	20 - 30	2 - 3	17 - 26	
Regular bolt, nut, and screw		M 3	6 - 10	0.6 - 1.0	5 - 9
		M 4	15 - 25	1.5 - 2.5	13 - 22
		M 5	25 - 45	2.5 - 4.5	22 - 40
		M 6	45 - 75	4.5 - 7.5	40 - 65
		M 8	110 - 150	11 - 15	95 - 130

* Tapping screw

** Tapping bolt

*** Apply thread locking sealant (See next page)

1-4 Special repairing materials

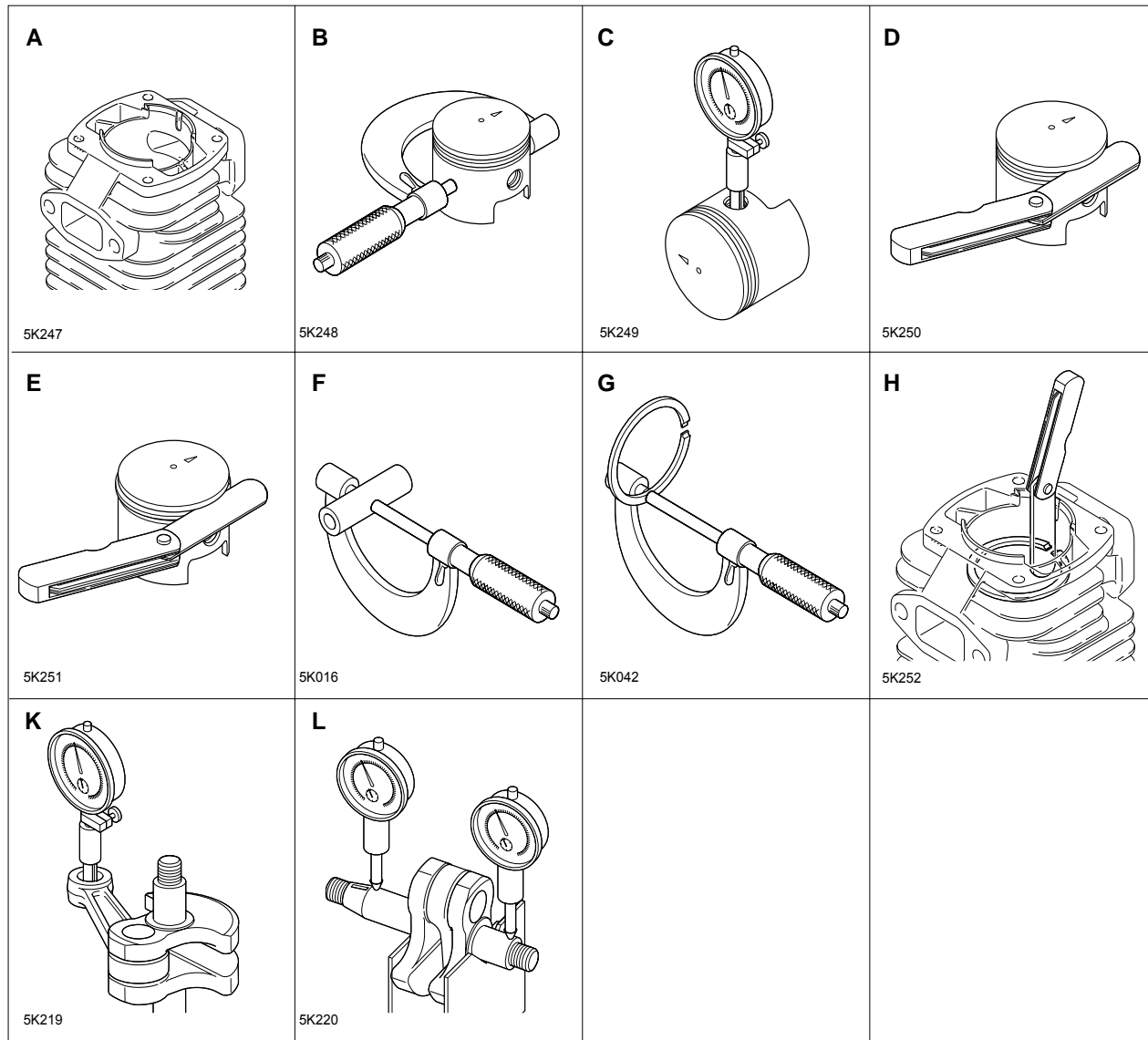

Material	Location	Remarks
Grease	Rewind spring	Lithium based grease
	Starter center post	
	Oil seal inner lips	
Thread locking sealant	Ball bearing	Loctite #675 or equivalent
	Muffler	Loctite #242, ThreeBond #1327 or equivalent
	Starter case	Loctite #222, ThreeBond #1344N or equivalent
	Cushion (Frame side)	Loctite #222, ThreeBond #1344N or equivalent

1-5 Service limits

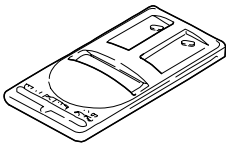
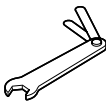
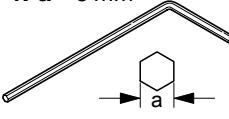
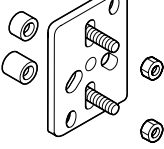
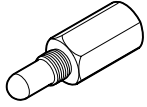
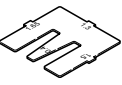
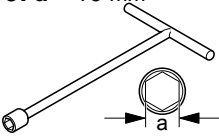
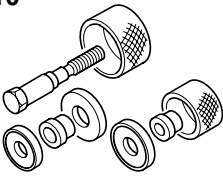
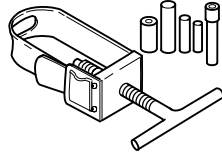
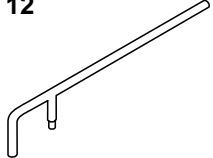
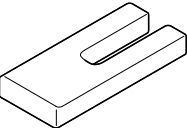
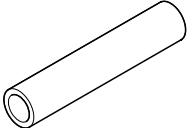
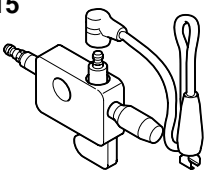
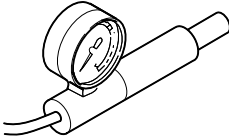
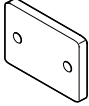

Description			mm(in)
A	Cylinder bore		When plating is worn and aluminum can be seen
B	Piston outer diameter	Min.	47.95 (1.888)
C	Piston pin bore	Max.	10.03 (0.395)
D	Piston ring groove, 1st	Max.	1.65 (0.065)
		2nd	Max. 1.6 (0.063)
E	Piston ring side clearance	Max.	0.1 (0.004)
F	Piston pin outer diameter	Min.	9.98 (0.393)
G	Piston ring width	Min.	1.45 (0.057)
H	Piston ring end gap	Max.	0.5 (0.02)
K	Con-rod small end bore	Max.	14.025 (0.552)
L	Crankshaft runout	Max.	0.05 (0.002)

1-6 Special tools

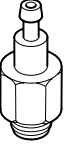
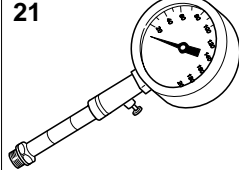
1 	2 	3: a = 4 mm 4: a = 5 mm 	5 	6 
7 	8: a = 8 mm 9: a = 10 mm 	10 	11 	12 
13 	14 	15 	16 	17 
18 	19 	20 	21 	

Key	Part Number	Description	Used for:
1	897801-33330	Tachometer PET-1000	4-3
2	895115-00330	Magneto wrench	3-9
3	895610-79920	L-hex wrench (4 mm)	
4	895611-79920	L-hex wrench (5 mm)	
5	897501-03938	Puller	8-6
6	897537-30130	Piston stopper	2-6, 7-3, 8-6, 8-8
7	897563-19830	Metering lever gauge	4-7
8	897558-02830	T-socket wrench(8mm)	
9	897558-10230	T-socket wrench(10mm)	
10	897701-14732	Bearing tool	8-11, 8-12
11	897702-30131	Piston pin tool	8-9, 8-16
12	897712-07930	2-pin wrench	2-6
13	897719-02830	Piston holder	8-9, 8-16
14	897726-21430	Oil seal tool	8-14
15	897800-79931	Spark tester	3-2
16	897803-30131	Pressure tester	4-4, 4-5, 8-4
17	897826-16131	Rubber plug	8-4
18	897827-16131	Pressure plate	8-4
19	897834-79930	Rubber plug	8-4
20	897835-16131	Pressure connector	8-4
21	91007	Compression gauge	8-1

2 STARTER SYSTEM

- (A) Pawl carrier
- (B) Starter pawl
- (C) Starter drum
- (D) Rewind spring
- (E) Starter case
- (F) Starter rope
- (G) Rope guide
- (H) Starter grip

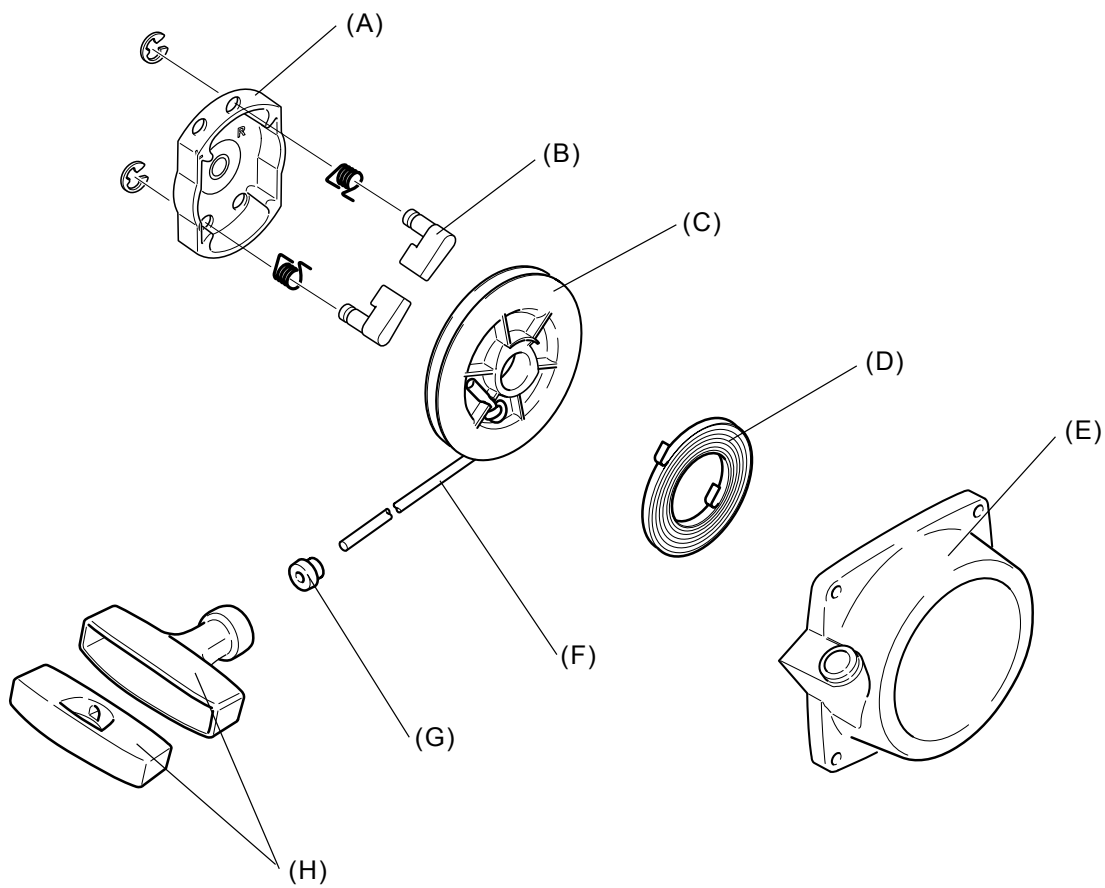

2-1 Removing starter drum and rope



1. Unscrew four bolts of starter case (A) to remove it from engine body.

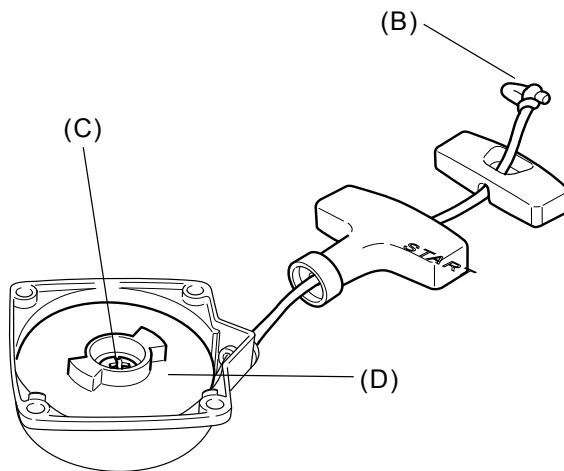

2. Pull off the starter rope knot (B) in starter grip .

3. Cut off or untie the knot (B) and allow rope to slowly rewind by holding starter drum.

4. Remove screw (C) and washer holding starter drum in starter case.

WARNING  **DANGER**
Be careful when removing starter drum;
rewind spring may unwind unexpectedly.

5. Turn starter drum (D) clockwise lightly and lift up drum slowly.

6. Unwind starter rope from starter drum, remove the knot from the end of rope, and remove rope from drum.

4K172E

2-2 Replacing rope guide

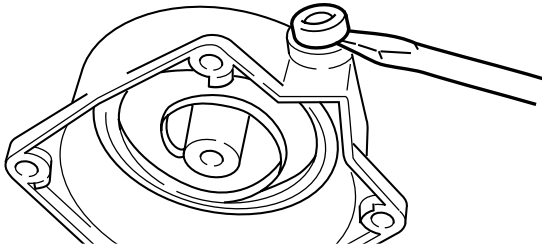

4K345

If rope guide is worn out or damaged, replace it as follows:

1. Remove or break rope guide by prying from starter case with a screwdriver.
2. Push out remaining guide from case.
3. Press new rope guide into starter case until it bottoms with a sound of click.

2-3 Installing rewind spring

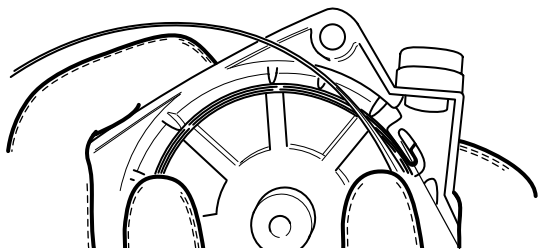

4K346

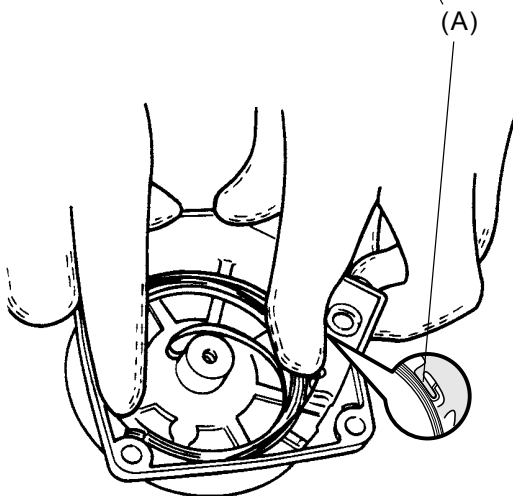

4K347

WARNING  **DANGER**

Use of eye protection and safety gloves are strongly recommended while working on rewind spring.

To remove rewind spring from starter case, hold spring tightly with a long nose pliers.

If rewind spring unwinds unexpectedly, follow steps 1) to 2).

- 1) Catch a hook at the outer edge of rewind spring on the inner part (A) of starter case. Wind rewind spring counterclockwise in starter case.
- 2) Apply small amount lithium based grease to out side of rewind spring.

NOTE: Rewind spring supplied as spare part is shipped in temporary retainer. The retainer should be removed when installing the new rewind spring.

To install new spring wound in retainer to starter case :

- 1) Align an outer hook of spring in retainer with a part (A) in starter case.
- 2) Push spring down into the bottom of case, keeping spring strongly pressed against case.
- 3) Spring should fall into case, and retainer is detached.

2-4 Installing starter drum and rope

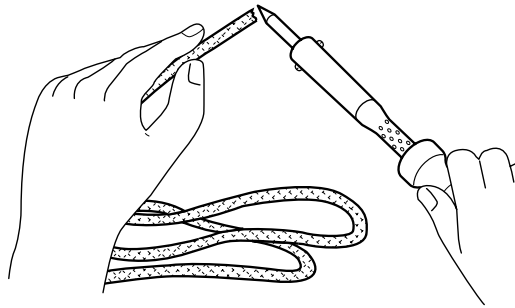

4K287

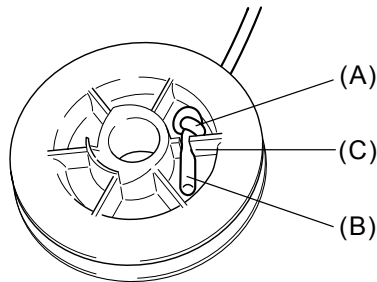

4K348

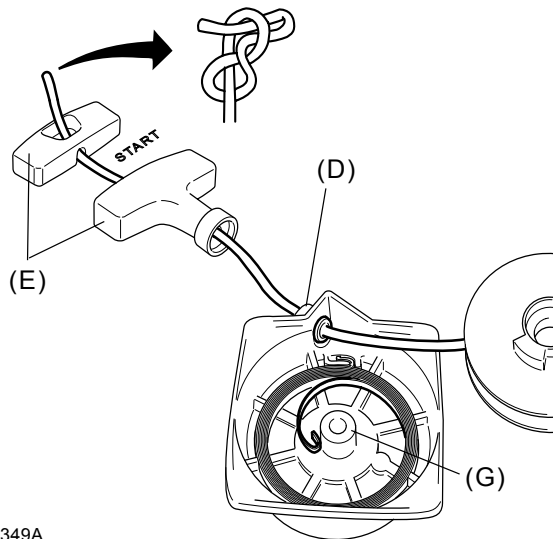

4K349A

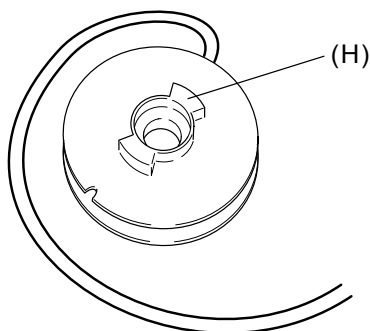

4K350

1. When installing a new starter rope, singe both ends of rope to prevent fraying.

WARNING  **DANGER**
Do not use flame in an area where gasoline is stored or flammable gases may exist.

2. Pass one end of rope through the opening in Starter drum and make a knot (A).
3. Pull Rope to seat the knot in Drum.
4. Pack excess rope (B) into the recess (C) of drum.

5. Pass loose end through rope guide (D) and starter grip (E).
6. Make another knot at the end of the starter grip side. Then press the knot into the recess of grip.
7. Bend the inner loop of rewind spring so that the inner hook lightly touches center post (G).
8. Lubricate center post (G) and the center hole of drum with grease (use any good quality lithium based grease).

9. Wind the rope onto drum about four turns counterclockwise as viewed from the pawl catcher (H) side.
10. Install drum in starter case. Make sure that drum engages with the inner end of rewind spring.
11. Install the washer and the screw holding drum in case. Use thread locking sealant (Loctite #222 or equivalent).

2-5 Increasing rope tension

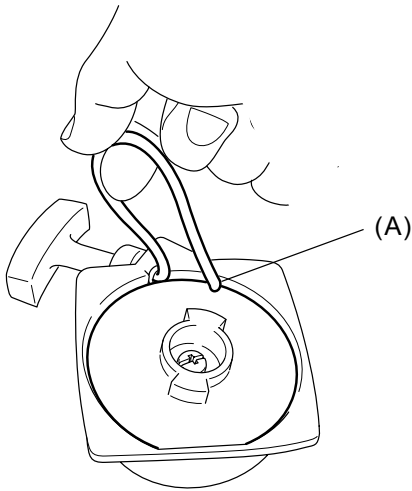

4K351

1. Pre-tension spring by rotating starter drum counterclockwise 3 to 4 turns with rope hooked at the notch (A).
2. Hold starter drum to prevent it from rewinding, and pull on starter grip, to take up the rope slack.
3. Let starter rewind slowly.
4. Pull starter several times to check the rewind spring tension.
5. If starter is not rewinding fully, rotate starter drum counterclockwise 1 extra turn with rope hooked at the notch (A).
6. Pull out starter rope all the way, and check that drum can be rotated more than half a turn counterclockwise.

2-6 Replacing starter pawl

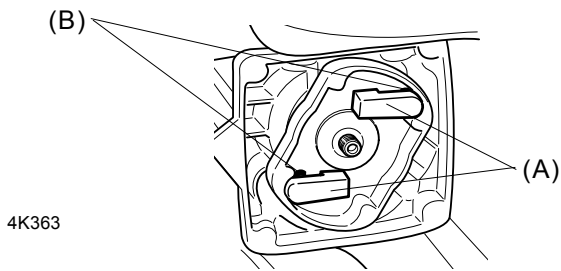

4K363

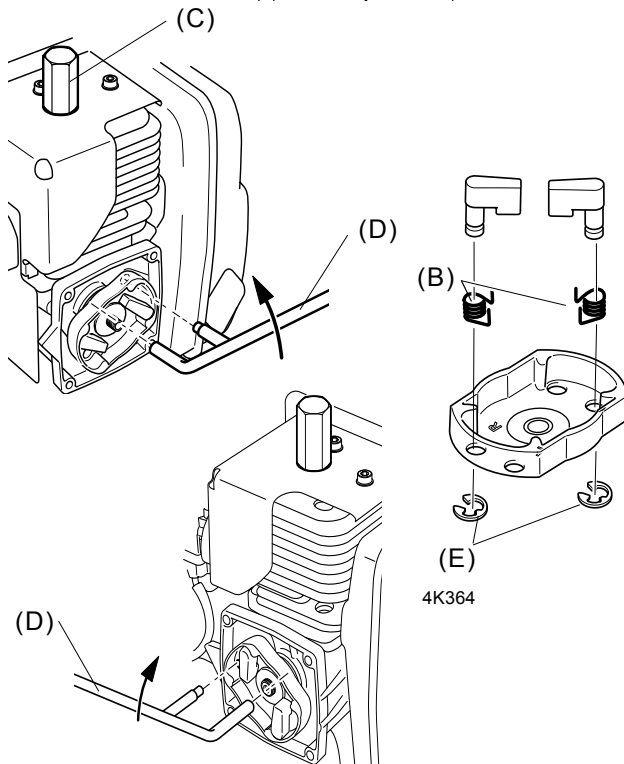

4K364

1. Remove starter assembly, and check starter pawl(s) (A) and pawl spring(s) (B). Replace them if defective.
2. Clean dirt from around spark plug, and remove spark plug.
3. Remove engine cover.
4. Insert piston stopper 897537-30130 (C) in the spark plug hole by hand.
5. Remove pawl carrier using 2-pin wrench 897712-07930 (D) .
6. Remove E-ring(s) (E) from pawl(s), and replace pawl(s) and/or return spring(s) as necessary.
7. Insert (new) spring(s) (B) to (new) pawl(s), and push pawl(s) into the hole(s). Then, install E-ring(s) (E) as shown.
8. Install pawl carrier hand tight temporarily to crankshaft.
9. Tighten pawl carrier using the 2-pin wrench (D) as shown.
10. Remove piston stopper. Install engine cover, spark plug and spark plug cap.
11. Install starter assembly, and other remaining parts.

3 IGNITION SYSTEM

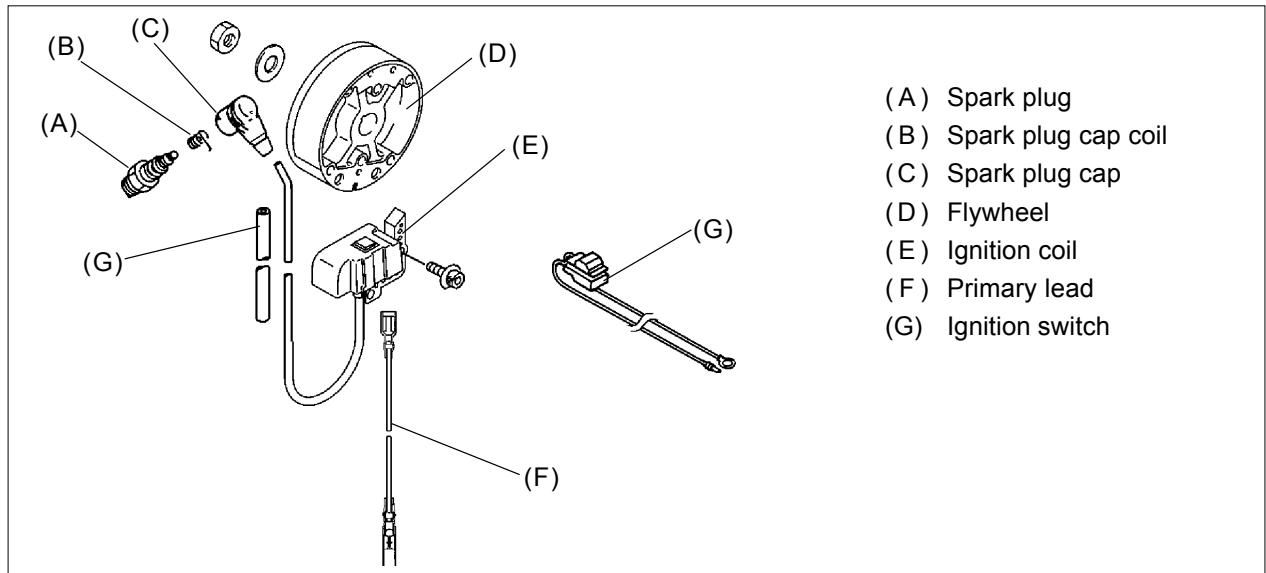

3-1 Troubleshooting guide

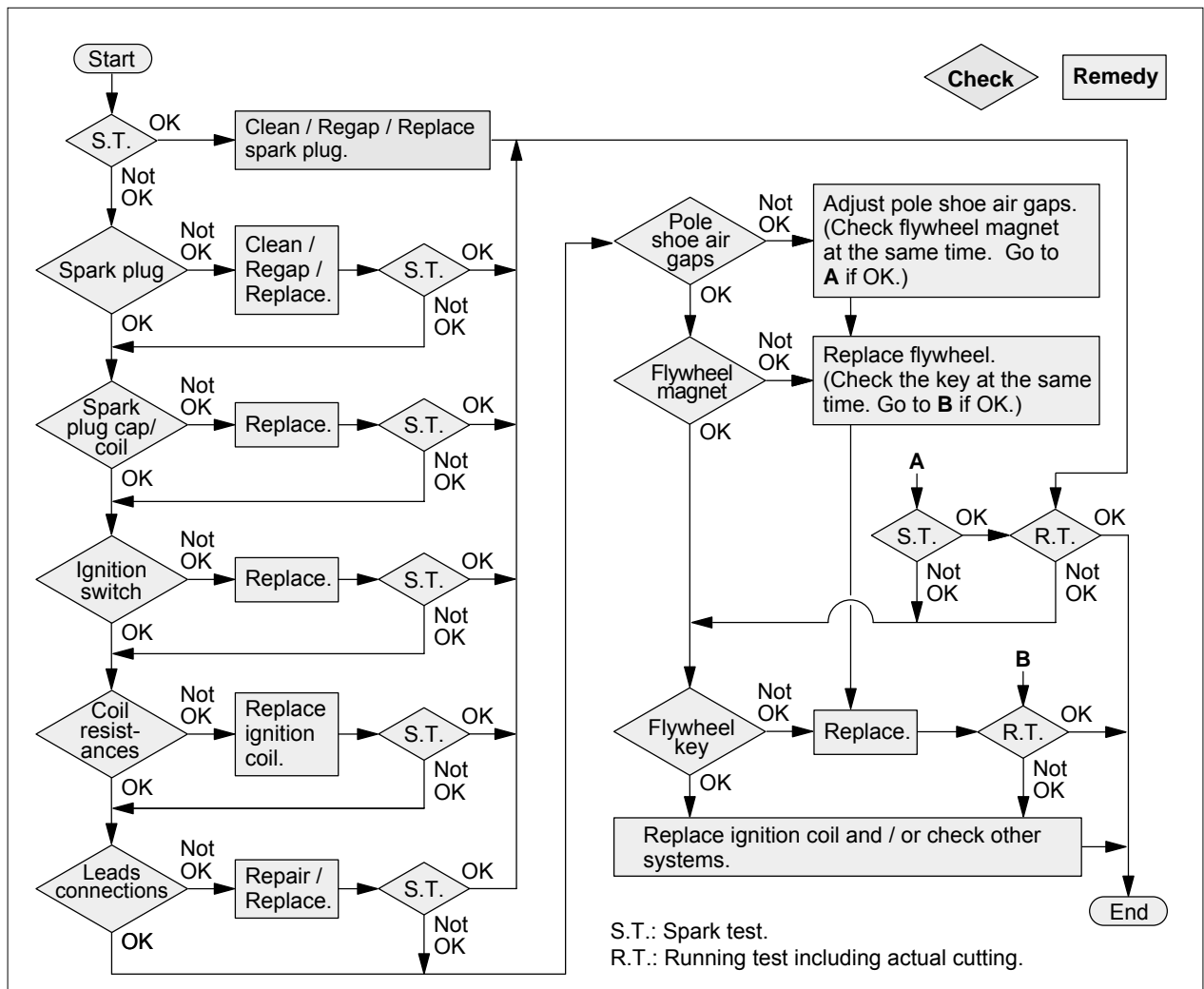

3-2 Testing spark

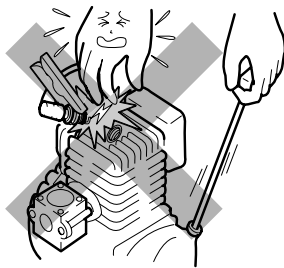

5K124

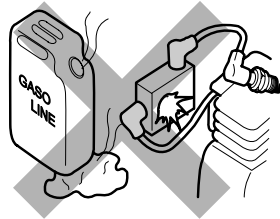

5K123

WARNING  **DANGER**

Do not touch the spark plug while performing the test to avoid receiving electric shock.

WARNING  **DANGER**

Do not check the spark in an area where gasoline is spilled or flammable gases may exist.

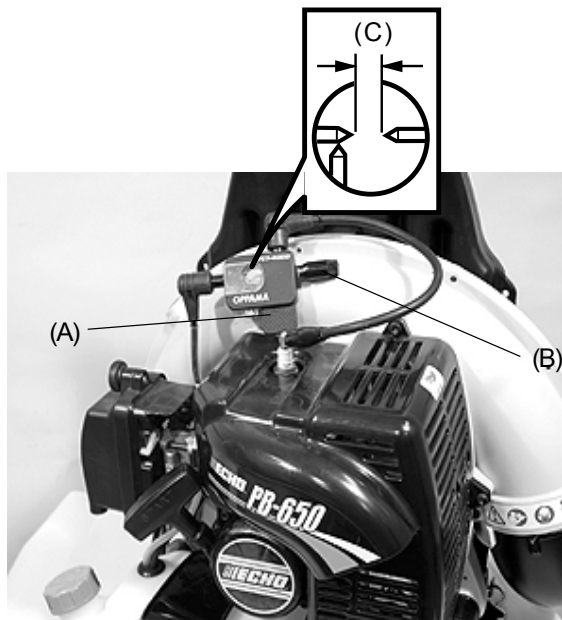

1. Disconnect the spark plug cap.
2. Connect the spark tester 897800-79931 (A).
3. Screw in adjuster (B) until the tips contact together and turn back four turns to set the spark tester gap (C) to 4 mm (0.16 in).
4. Turn the ignition switch to RUN position.
5. Pull the starter grip several times.
6. If the spark is blue, white and steady by the tester gap, the ignition system is considered good. Go to "3-3 Checking spark plug".
7. If no spark exists or spark is red, yellow or intermittent, continue with further tests according to "3-1 Troubleshooting guide".

3-3 Checking spark plug

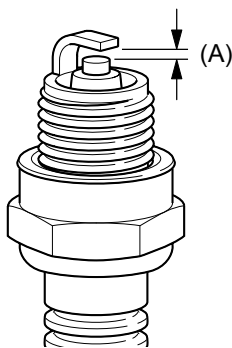

3K069

1. Remove the spark plug, check for fouling and worn, and rounded center electrode.
2. Clean the plug electrodes and insulator of carbon deposits, or replace with a new plug.
3. Set the spark plug gap to 0.6 to 0.7 mm (0.024 to 0.028 in) by bending the outer electrode.
4. If the engine does not start after cranking several times, check if the spark plug is wet or dry. If it is excessively dry or wet, check the fuel system.

3-4 Replacing spark plug cap and coil

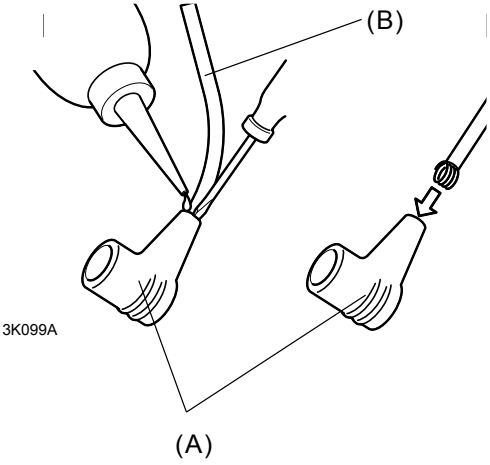

3K099A

1. Disconnect the spark plug cap (A).
2. Drip some oil in the cap (A) to aid in removing the cap.
3. Remove spark plug cap (A) from high tension lead (B).
4. Check the coil for correct connection and the cap for cracks. Replace as required.

NOTE: Make sure the coil contacts the core of the high tension lead when reinstalling it.

3-5 Checking coil resistance



1. Connect one probe of an ohm-meter or a multi-meter to spark plug cap coil and the other end to crankcase or a clean ground.
2. Measure the secondary coil resistance. The resistance should be in the range of 1.2 and 1.8 k Ω ; if the value is not in the range, replace with a new ignition coil.

3-6 Checking ignition switch



1. Disconnect lead coupler at bottom of unit and connect the probes of an ohm-meter or a continuity tester to the switch side of lead coupler and terminal.
2. When the ignition switch is in RUN position, the tester should indicate infinite resistance.
3. When the ignition switch is STOP position, the tester should show that the circuit is in conduction state (close circuit).
4. If the ignition switch is defective, replace with a new one.

3-7 Checking flywheel magnets

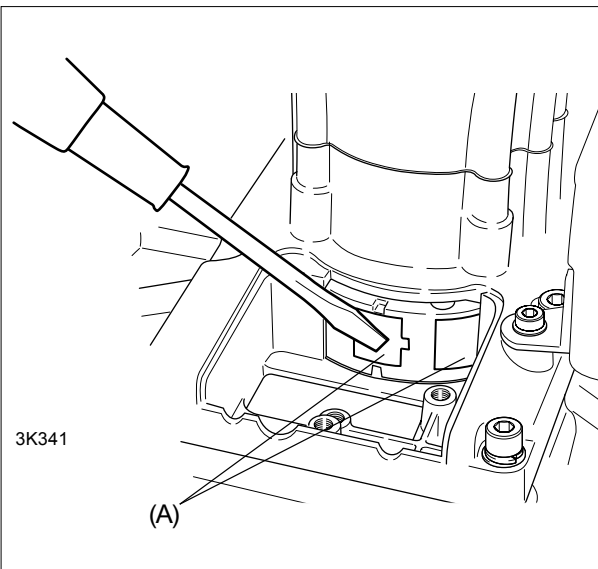

1. Remove spark plug and engine cover.
2. Disconnect fuel pipes from carburetor.
3. Loosen the bolts for the outer part of fuel tank band, and then pull out fuel tank.
4. Remove dust cover from bottom of crankcase.
5. Remove ignition coil.
6. Rotate flywheel until the magnets are visible at the opening of crankcase wall.
7. Check magnetic force of flywheel (A) using flux meter or bridging with a screwdriver and comparing with a good one.
8. If it is defective, replace with new one.

3-8 Replacing ignition coil

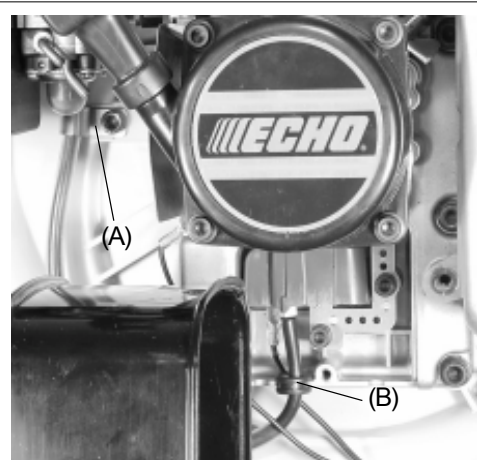

1. Remove the spark plug cap, ignition coil, throttle wire bracket (A) and tube from high tension lead of the defective ignition coil.
2. Reinstall those parts to high tension lead of a new ignition coil.
3. Temporarily install ignition coil.
4. Install grommet (B) to high tension lead of the new ignition coil together with primary lead.
5. Insert the grommet to the notch of crankcase bottom wall.

3-9 Setting pole shoe air gaps

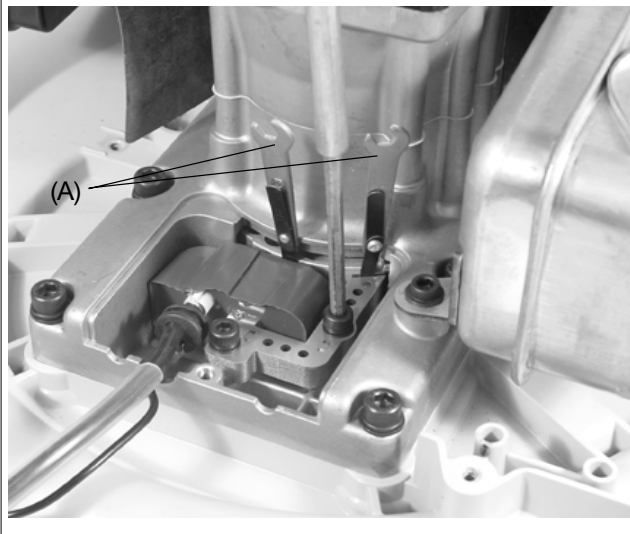

1. Loosen ignition coil bolts and insert 0.3 mm (0.012 in) feeler gauges of two magneto wrenches 895115-00330 (A) respectively between both ends of ignition coil core and flywheel magnets.

2. While holding ignition coil against the feeler gauge between magnets of flywheel and ignition coil, tighten bolts.

Standard gaps : 0.3-0.4mm

NOTE: If air gaps are too wide, this system will not generate sufficient energy and give a weak spark or an incorrect ignition timing. If the gaps are too close, the ignition coil can interfere with the flywheel.

3-10 Assembling dust cover and lead

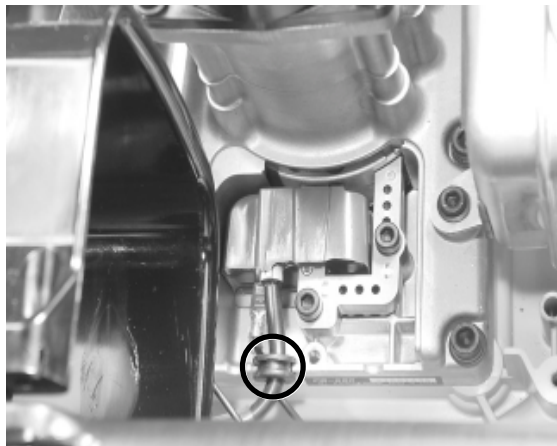

1. Set grommet into the notch of crankcase as shown.

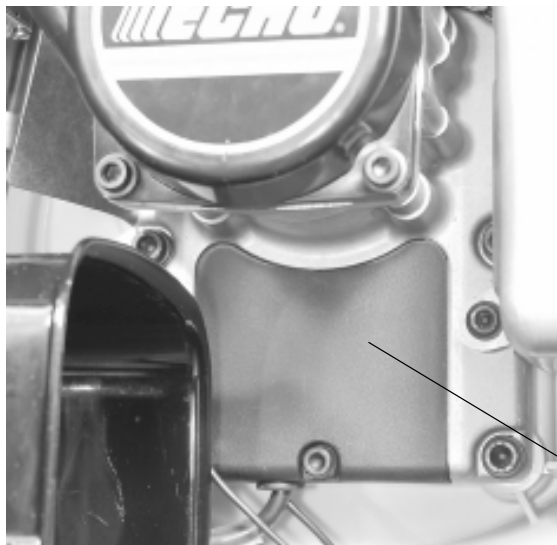

2. Insert flywheel side corner of dust cover (A) into crankcase and then press in bottom side of the cover while pushing the flywheel side corner to crankcase.

3. Make sure that grommet on high tension lead is properly seated between crankcase wall and dust cover (A).

4. Fasten dust cover (A) with a bolt.

5. Connect primary lead coupler and reinstall other remaining parts in place.

4 FUEL SYSTEM

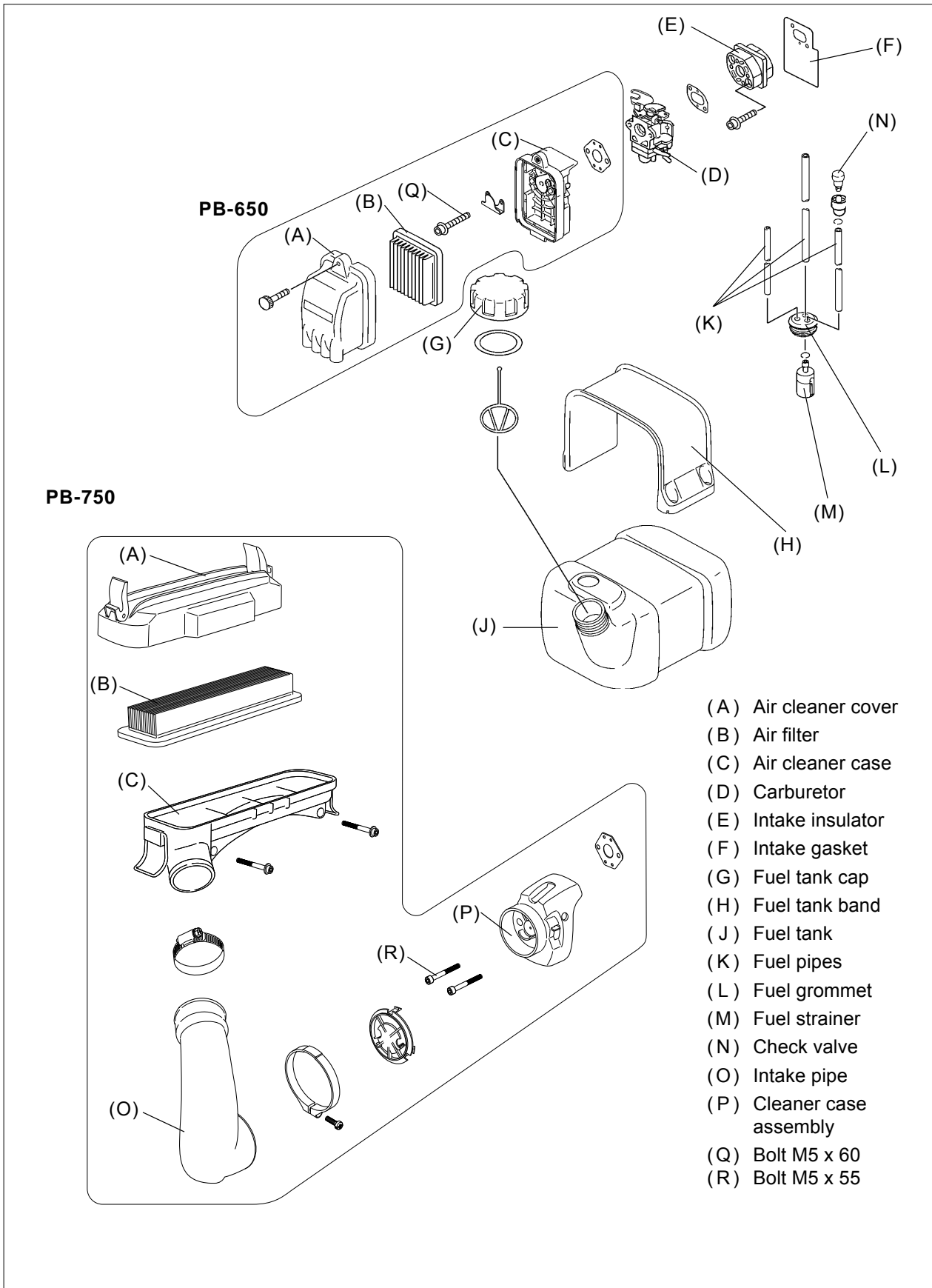

4-1 Cleaning air filter

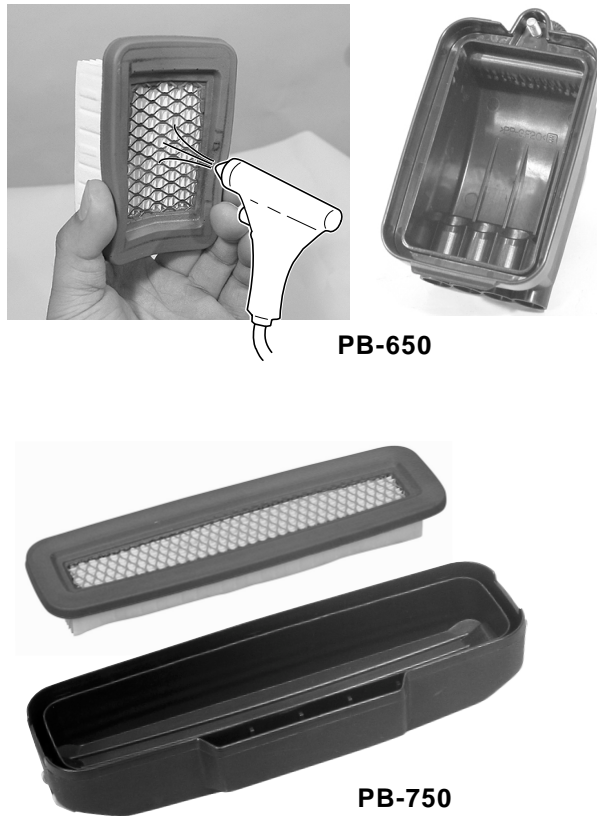

1. Close the choke shutter to prevent dust entering cylinder and remove the air cleaner cover and the air filter.
2. Clean the air filter and the cover with compressed air.

WARNING  **DANGER**
Wear eye protection when working with compressed air. Eye damage can occur from flying particles.

3. Replace the air filter if heavily soiled or damaged.

4-2 Checking fuel cap and strainer

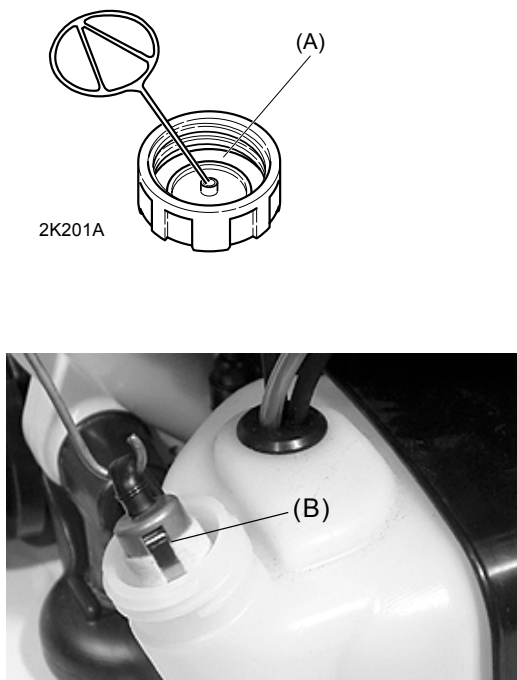

1. Remove fuel cap.
2. Check fuel cap for cracks and gasket (A) for cuts or damage. Replace defective parts as required.
3. Pull fuel strainer (B) from fuel tank using a wire hook and replace with a new one if it is blocked with dirt.
4. Reinstall fuel cap.

4-3 Adjusting carburetor

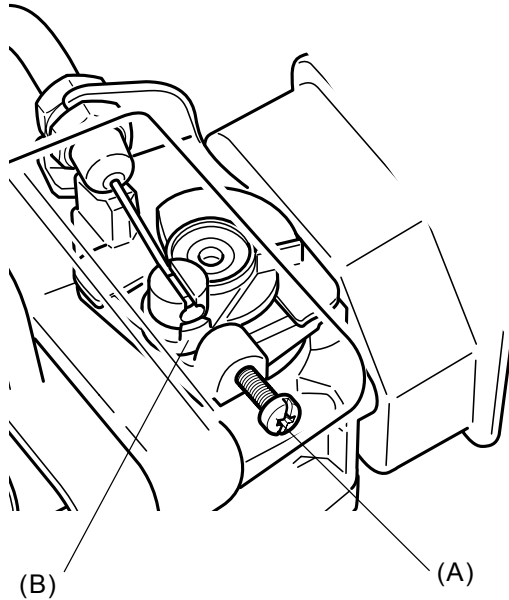

2K470

GENERAL ADJUSTMENT RULES:

Before starting the unit for adjustment, check the following items:

- Air filter must be cleaned and properly installed.
- Exhaust port of muffler must be clear of carbon.
- The unit must be equipped with blowing pipes.

REQUIRED TOOLS:

- Screwdriver
- Electronic digital tachometer

1. Turn out idle speed screw (A) counterclockwise until its tip just touches throttle plate (B). Then turn it in clockwise 1 and 1/2 (one and half) turns.
2. Start engine and warm-up at idle more than three minutes.
3. Turn idle speed screw (A) to set engine speed to 2,200 to 2,800 rpm on the tachometer.
4. Check that Engine speed at full throttle operation (WOT) is more than approx. 7,000 rpm on the tachometer.
5. If carburetor can not be adjusted correctly as above, check carburetor assembly (Refer to "4-9 Checking diaphragm and others").

4-4 Testing carburetor

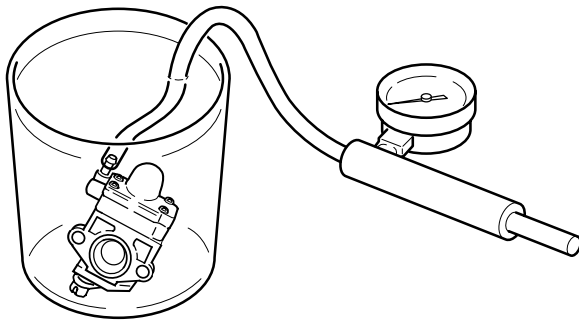

2K209A

1. To fill and wet fuel pump circuit with fuel, push purge pump several times.
2. Pull off black fuel line from carburetor and connect pressure tester 897803-30131 (A) to fuel inlet on carburetor.
3. Apply pressure to approx. 0.8 kgf/cm^2 (10 psi). The pressure should remain over 0.5 kgf/cm^2 (7 psi).
4. If it drops below 0.5 kgf/cm^2 (7 psi), re-tighten pump cover and repeat the previous Step 3. If it still drops rapidly, proceed to Step 6 to locate the leak.
5. Apply pressure to 0.5 kgf/cm^2 (7 psi) and push purge pump. Pressure should drop. If it does not drop, check the metering lever height for too low of a setting (according to "4-7 Checking metering lever"), or Inlet needle valve for sticking (according to "4-8 Checking inlet needle valve").
6. Remove fuel return pipe and throttle wire from carburetor, then remove carburetor from engine. With pressure tester still attached, submerge carburetor in suitable clean solvent and apply 0.5 kgf/cm^2 (7 psi) pressure to locate the leak.
7. If the air bubbles come out between the pump body and the carburetor body, check the pump diaphragm, pump gasket, and diaphragm seat of carburetor body.
8. If the air bubbles come out from the carburetor bore, check inlet valve, metering lever spring and the metering lever height.

4-5 Checking fuel tank and vent

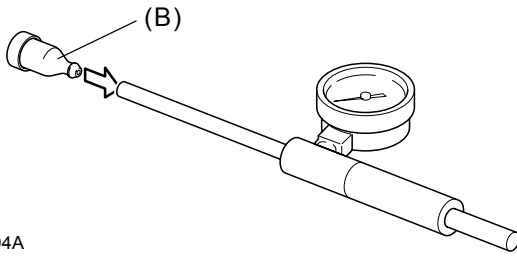
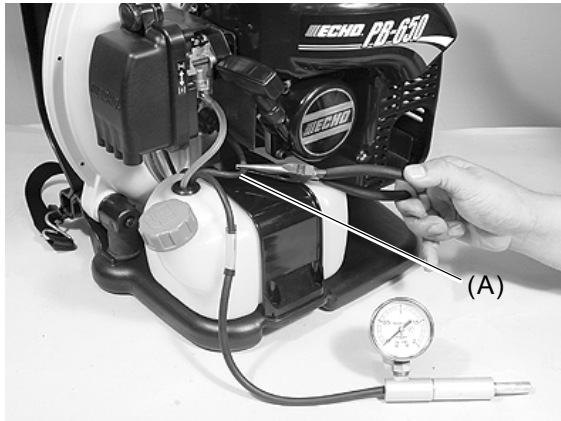

2K194A

1. Disconnect black fuel line from carburetor and connect pressure tester 897803-30131 to fuel line with an appropriate joint.
2. Pinch vent pipe (A) to block the air passage, and apply 0.1 kgf/cm² (1.5 psi) of pressure.
3. The pressure should not drop. If the pressure drops, leakage may be occurring from fuel cap gasket, fuel tank, fuel line, grommet or vent line. Check them and replace defective parts with new ones.
4. Release the vent pipe. The pressure should stay at or above 0.1 kgf/cm² (1.5 psi). If pressure drops, vent or vent pipe is defective.
5. To check vent, remove vent, and connect pressure tester to vent (B).
6. Apply 0.5 kgf/cm² (7.0 psi) and check if the pressure stays between 0.1 to 0.4 kgf/cm² (1.5 to 5.5 psi).
7. If the pressure is out of range, clean vent gently with compressed air or replace with a new vent assembly.

4-6 Replacing fuel line and grommet

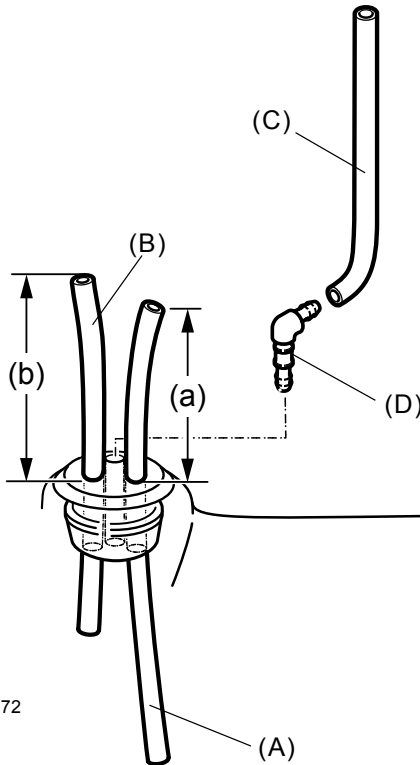

2K472

1. Disconnect fuel pipes from carburetor.
2. Remove grommet with pipes from fuel tank. Pull off fuel strainer from the end of pipe (A).
3. Pull out defective pipe (A) and pipe (B) from grommet and pull out pipe (C) from pipe joint (D) (and remove pipe joint (D) from grommet, if pipe joint is defective).
4. Insert new pipe as follows:

Pipe		(A)	(B)	(C)
		Black (Strainer)	Transparent (Return)	Black (Vent)
Length	mm	230	145	145
	(inch)	(9.06)	(5.71)	(5.71)
Distance		(a)	(b)	---
	mm (inch)	99~101 (3.90 ~3.98)	104~106 (4.10 ~4.17)	

(continued)

4-6 Replacing fuel line and grommet (continued)

4. Reinstall grommet to fuel tank together with pipe joint and pipes.

NOTE: Pipe joint (D) (part number : V186-000080) has not installed on the unit serial number 35003000 and before. When replacing fuel pipe (C) of the above units, addition of pipe joint is recommended.

5. Reinstall all the parts that have been removed in place.

4-7 Checking metering lever

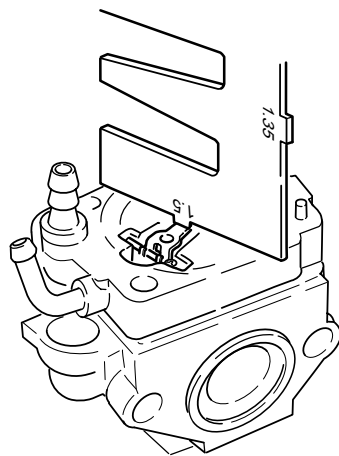

2K423A

1. Disconnect throttle cable from carburetor, then pull off fuel pipe and fuel return pipe from carburetor and remove carburetor.

2. Remove purge pump, air purge body, metering diaphragm, and gasket.

3. Check the metering lever height using metering lever gauge 897563-19830. If necessary, gently bend the lever up or down to set the metering lever at the correct position of 1.5 mm (0.06 in) as shown.

NOTE: When the metering lever is:

Too high → Fuel flooding

Too low → Fuel starvation/overheating

4-8 Checking inlet needle valve

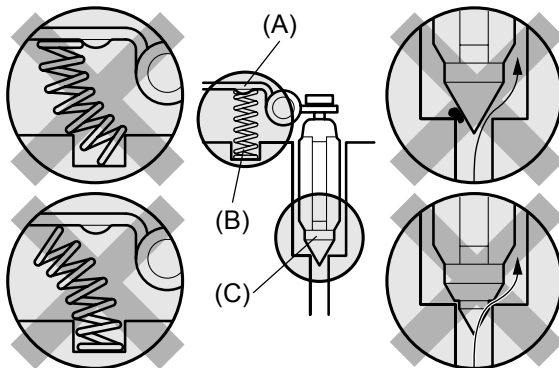

2K005B

1. Remove the metering lever pin with the lever (A), spring (B), and inlet needle valve (C).

2. Inspect the inlet needle valve if worn or stuck. Clean or replace as required.

NOTE: Causes of the fuel flooding from carburetor to the cylinder are as follows:

- Improper assembling of the metering lever and spring.
- Dirt between the inlet needle valve and the seat.
- Worn inlet needle valve tip.

3. Clean the valve seat.

4. Assemble the metering lever, inlet needle valve, pin, and spring.

NOTE: Make sure that the spring is seated in its hole at the chamber floor under dimple of the metering lever and that the metering lever is holding the inlet needle valve.

4-9 Checking diaphragm and others

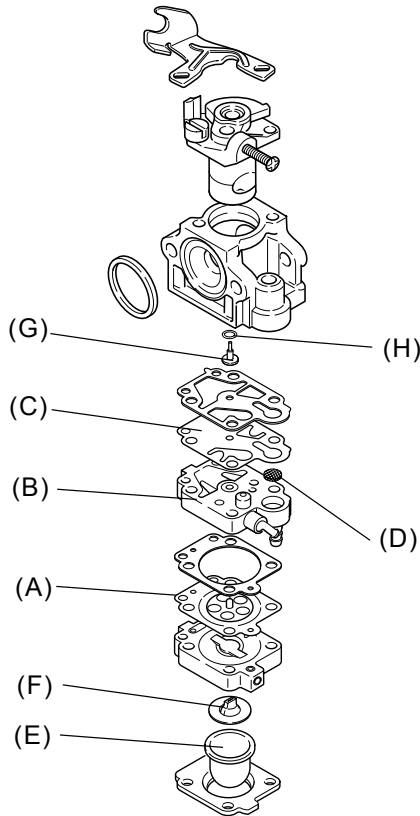

2K463

1. Check metering diaphragm (A) for hardening, distortion, or pin hole. Replace it as required.
2. Remove pump body assembly (B) and pump diaphragm (C).
3. Check pump diaphragm, and replace it if hardened or curled at the valve tabs.
4. Check metering and pump gaskets, and replace if defective.
5. Check inlet screen (D) if blocked with dust. Remove and clean it, or replace it if defective.
6. Check purge bulb (E) for crack or fatigue. Replace it as required.
7. Check the slit of check valve (F) if deformed or resinous. Replace it as required.
8. Check main jet (G) if clogged. Replace it as required, referring to "4-10 removing main jet".
9. Check O-ring (H) for crack or fatigue. Replace it as required.
10. Clean the fuel passages in carburetor body with gentle compressed air.

4-10 Removing main jet

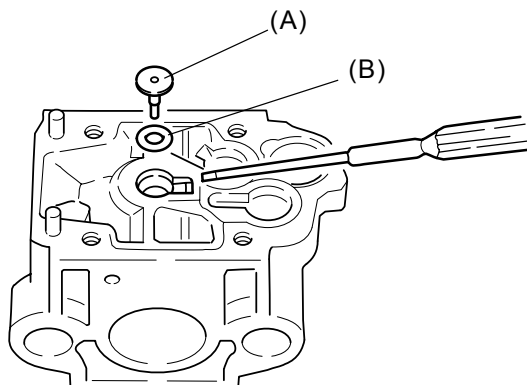

2K375

1. Carefully pry main jet (A) from carburetor with a small screwdriver.
2. Inspect O-ring (B) under main jet and replace if necessary.
3. Clean the fuel passage of carburetor body.
4. Clean main jet or replace it.

	Main jet
PB-650	#58.5
PB-750	#50

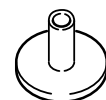

(PB-650)

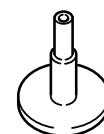

(PB-750)

4-11 Checking pulse passage

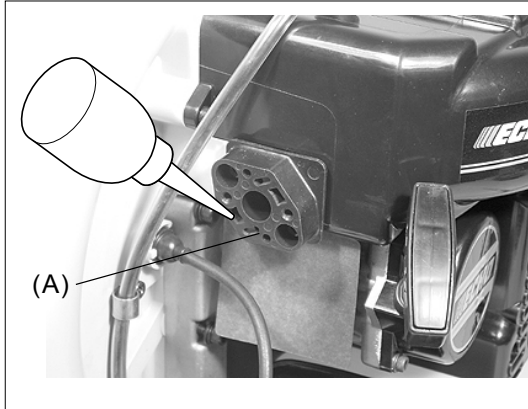

1. Remove carburetor, and drop a little oil in the pulse hole (A) on Insulator.
2. Remove spark plug and pull starter grip several times. Oil should spit back from the hole.
3. If not, remove Insulator and gaskets. Check gaskets for misassembly or remove the oil residue clogging the pulse passages in insulator and cylinder.
4. Install gasket and insulator and the other remaining parts.

4-12 (Option) Assembling heavy duty air cleaner kit for PB-650 (Part number : P021-007160)

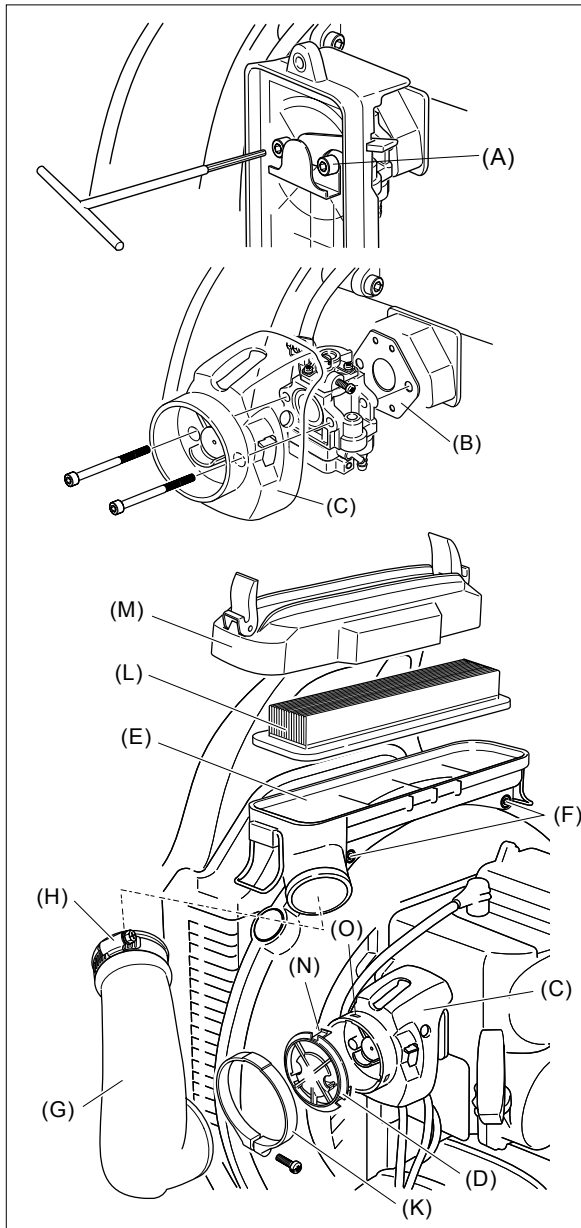

1. After removing air cleaner lid and air filter, loosen bolt 900105-05060 (A) to remove air cleaner case, carburetor and intake gasket.
2. Assemble new intake gasket (B), carburetor and cleaner case (C) with bolt 900105-05055 as shown.
Torque limits : 40 - 55 kgf•cm (4.0 - 5.5 N•m).
3. Install prevent plate (D) to cleaner case (C) meeting the notch (N) with hole (O) on cleaner case.
4. Install air cleaner case (E) on fan case using 2 bolts (F).
5. Connect intake pipe (G) with air cleaner case (E) and secure it with band (H).
6. Connect intake pipe (G) with cleaner case assembly (C) and secure it with clamp (K).
7. Install air filter (L) and air cleaner lid (M).
8. After installing air cleaner kit, make it sure engine running condition.

5 HANDLE AND CONTROL SYSTEM

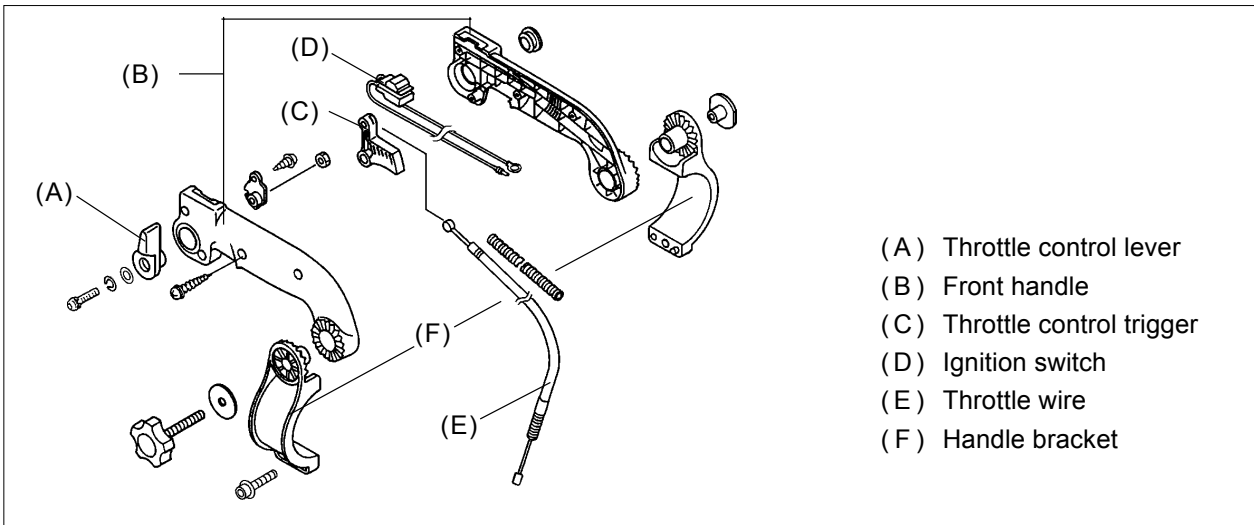

5-1 Adjusting handle position

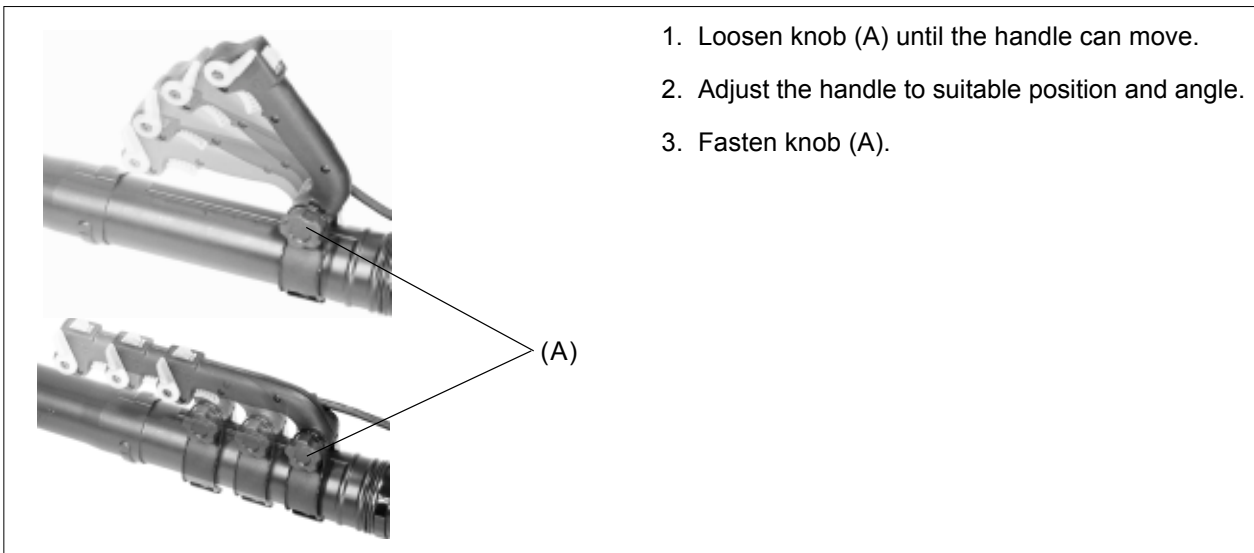

5-2 Removing handle

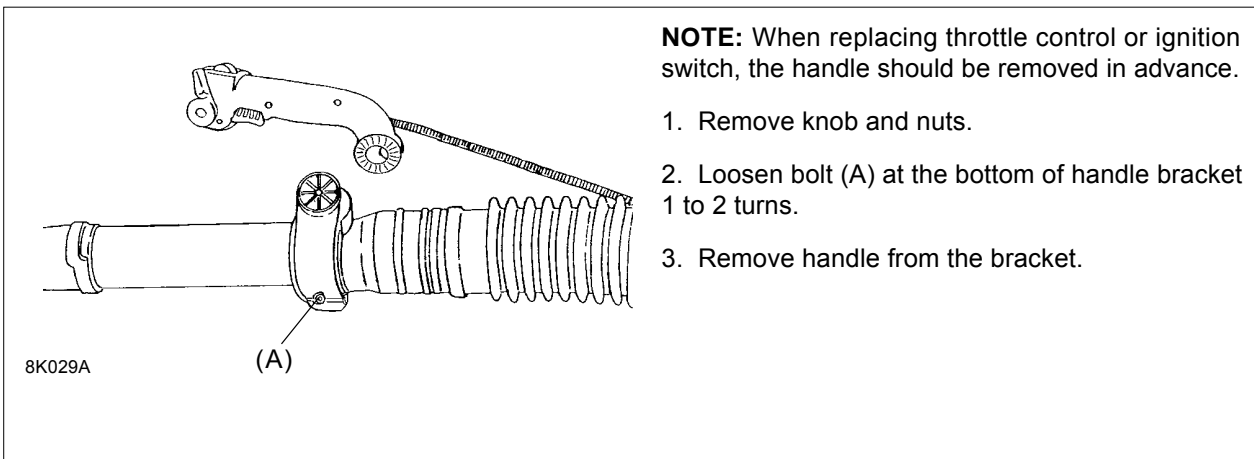

5-3 Replacing throttle wire and switch

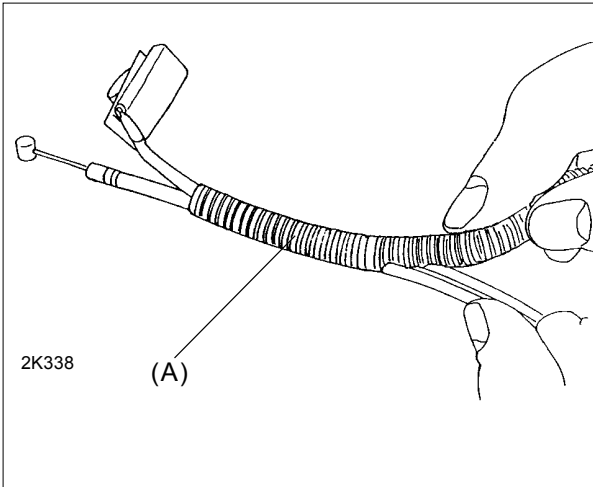

1. Disconnect lead coupler, terminal and throttle cable at the engine side.
2. Separate the right side half of handle. Remove throttle control part and ignition switch.
3. Remove tape from corrugated tube (A).
4. Separate corrugate tube (A) from cable and leads all the way.
5. Push in new throttle cable and two leads of new ignition switch together into corrugate tube (A).
6. Wrap a tape 2 turns at the engine side and end of the tube.

5-4 Adjusting throttle control lever friction

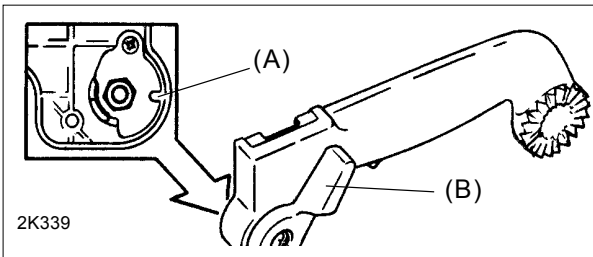

1. Loosen the nut (A) inside handle.
2. Turn the screw (B) securing throttle control lever to adjust the lever friction.
3. Tighten nut (A) holding the screw.

5-5 Assembling handle

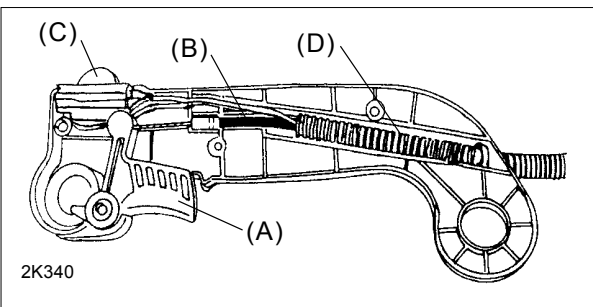

1. Connect throttle wire end to throttle control trigger (A).
2. Put the throttle control trigger (A), throttle wire (B), ignition switch (C), and corrugated tube (D) in the right side half of handle.
3. Put together both handle halves.

5-6 Positioning throttle wire and tube

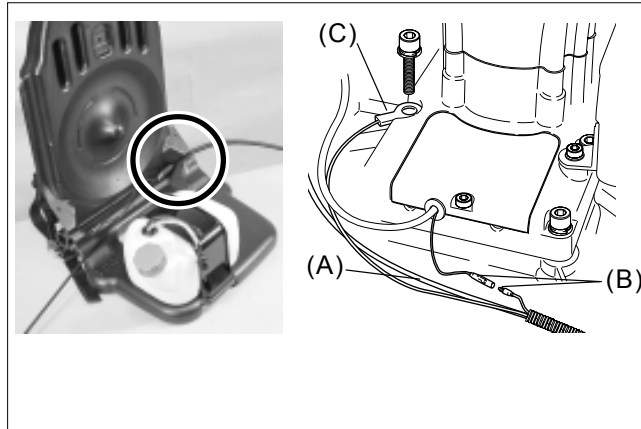

1. Pass corrugate tube housing, throttle cable etc. through the right side bottom hole of backpack frame as shown.
2. Lay throttle wire (A) between fan case and fuel tank.
3. Connect lead coupler (B), and secure bolt to the middle left of crankcase together with ground lead terminal (C).

5-7 Adjusting throttle wire

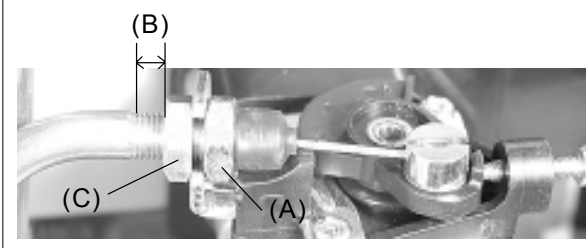

1. Loosen nut (A) and adjust the length (B) to 5 - 6 mm by turning nut (C). Fix the length (B) by tightening nut (A).

5-8 (Option) Assembling static protection kit (Part number : 900500)

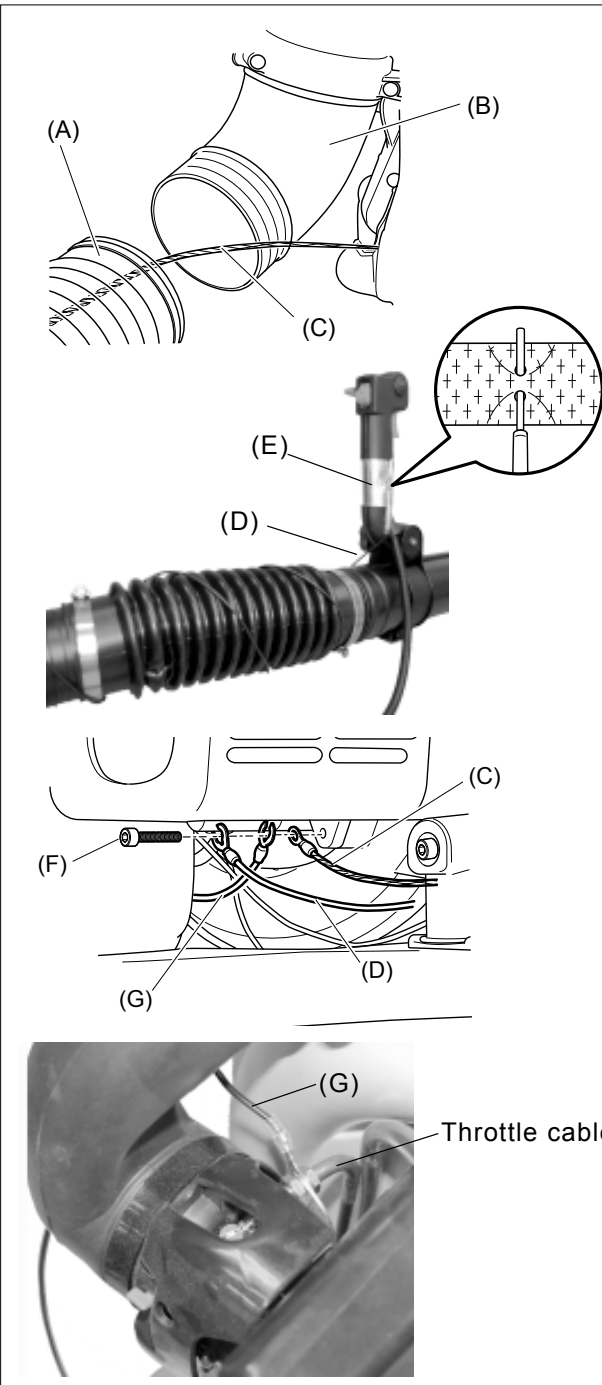

1. Disassemble flexible pipe (A) from main pipe (B).
2. Insert plaited lead (C) (approx. 500mm) into flexible pipe (A) as shown.

NOTE : Allow enough slack to assure free movement of main pipe (B).

3. Insert copper pipe end of lead (D) into holes of aluminized tape (E) and stick them to handle.
4. Wrap lead around flexible pipe to take up the slack of lead with copper pipe (D).
5. Remove bolt (F) from lower engine cover and secure the eyelet end of plaited lead (C), the open eyelet end of lead with copper pipe (D) and the eyelet end of lead (G) with bolt (F).
6. Route lead (G) behind fuel tank and below engine, and secure the open eyelet end by nut of throttle cable as shown.

6 BACKPACK FRAME

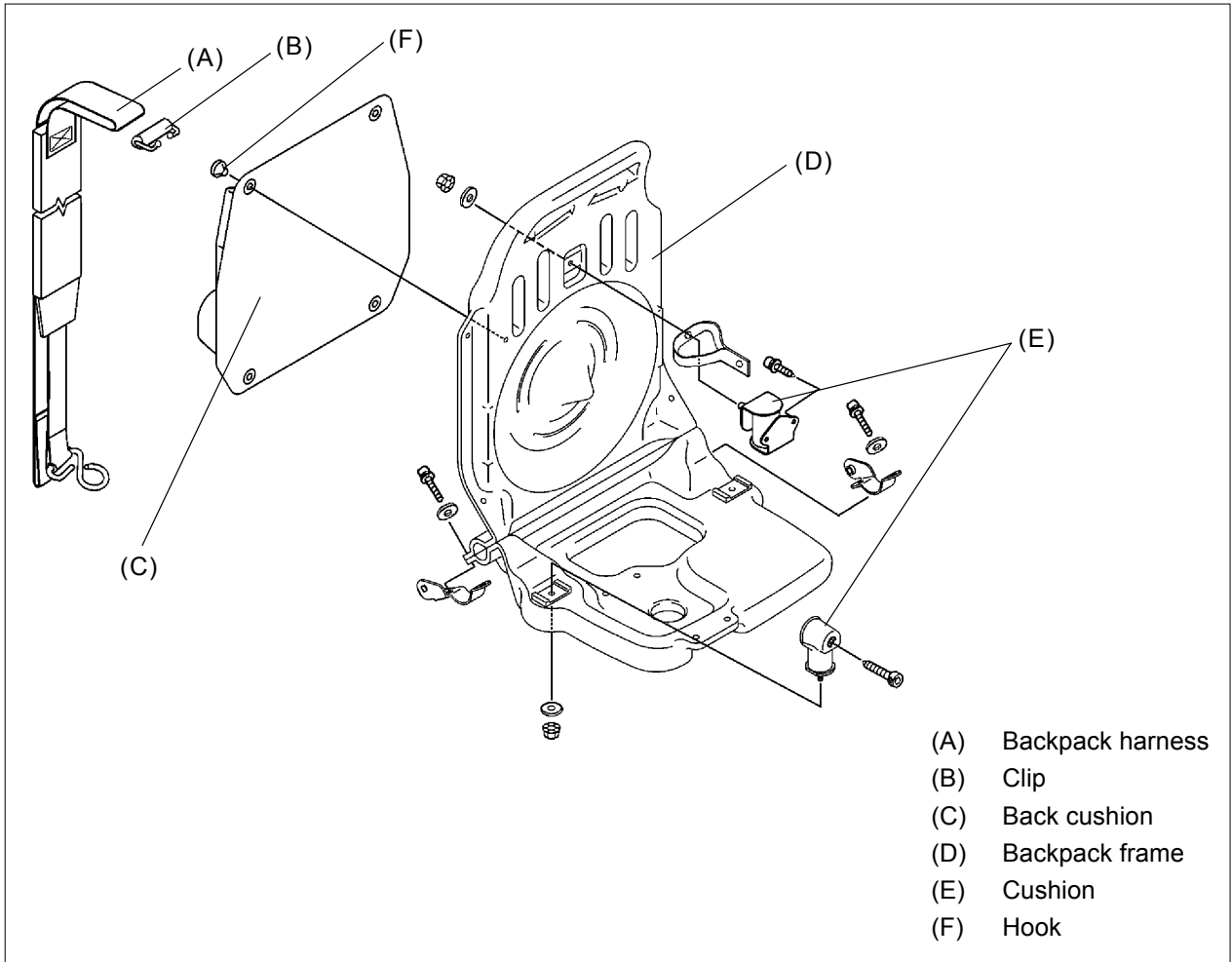

6-1 Replacing back cushion and harness

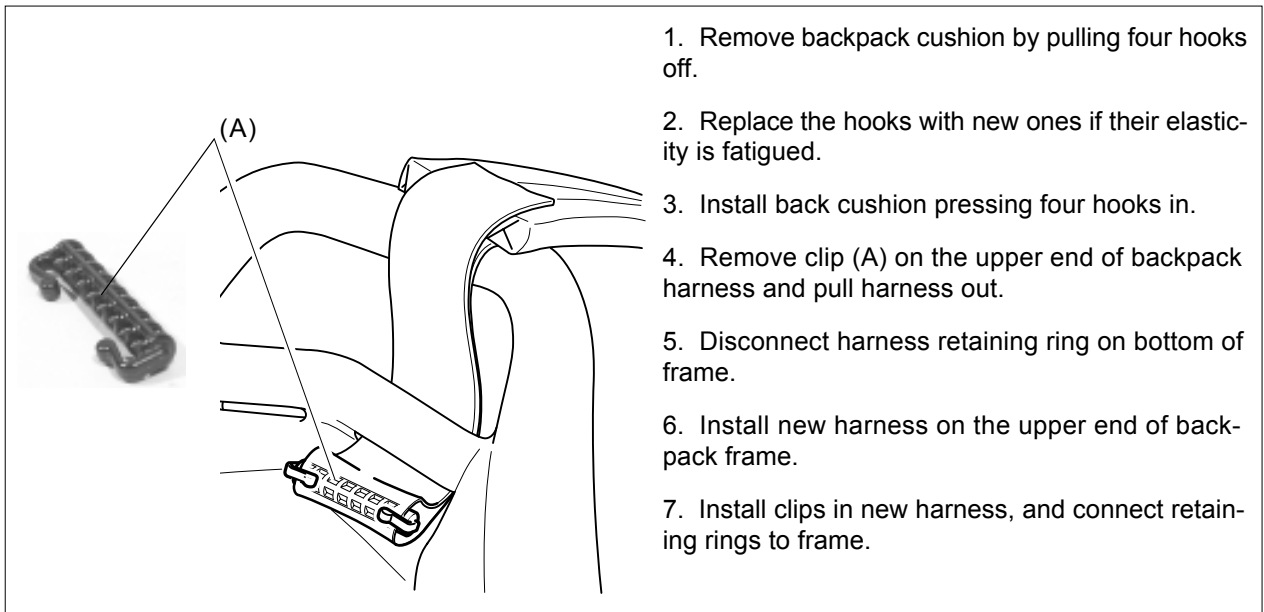

6-2 Removing backpack frame

2K471 (A)

(B)

(C)

(D)

(E)

(F)

8K046

1. Disconnect throttle wire and fuel pipes from Carburetor.
2. Disconnect primary lead coupler (A) and remove ground lead terminal (B) from crankcase.

For the units of PB-650 serial number up to 35003140

3. Remove three nuts and washers (C) on frame and disconnect engine unit from frame.

For the units of PB-650 serial number 35003141 to 35999999, and for the units of PB-750 up to 35999999

3. Remove three nuts and washers (C) on frame.
4. Remove four bolts (D), spacers (E) and flange nuts (F) and dismount engine units from frame.

6-3 Checking rubber cushions

(A)

Check three rubber cushions (A) on fan case for crack, wear, or peeling from the metal fixture. Replace as required.

7 BLOWER SYSTEM

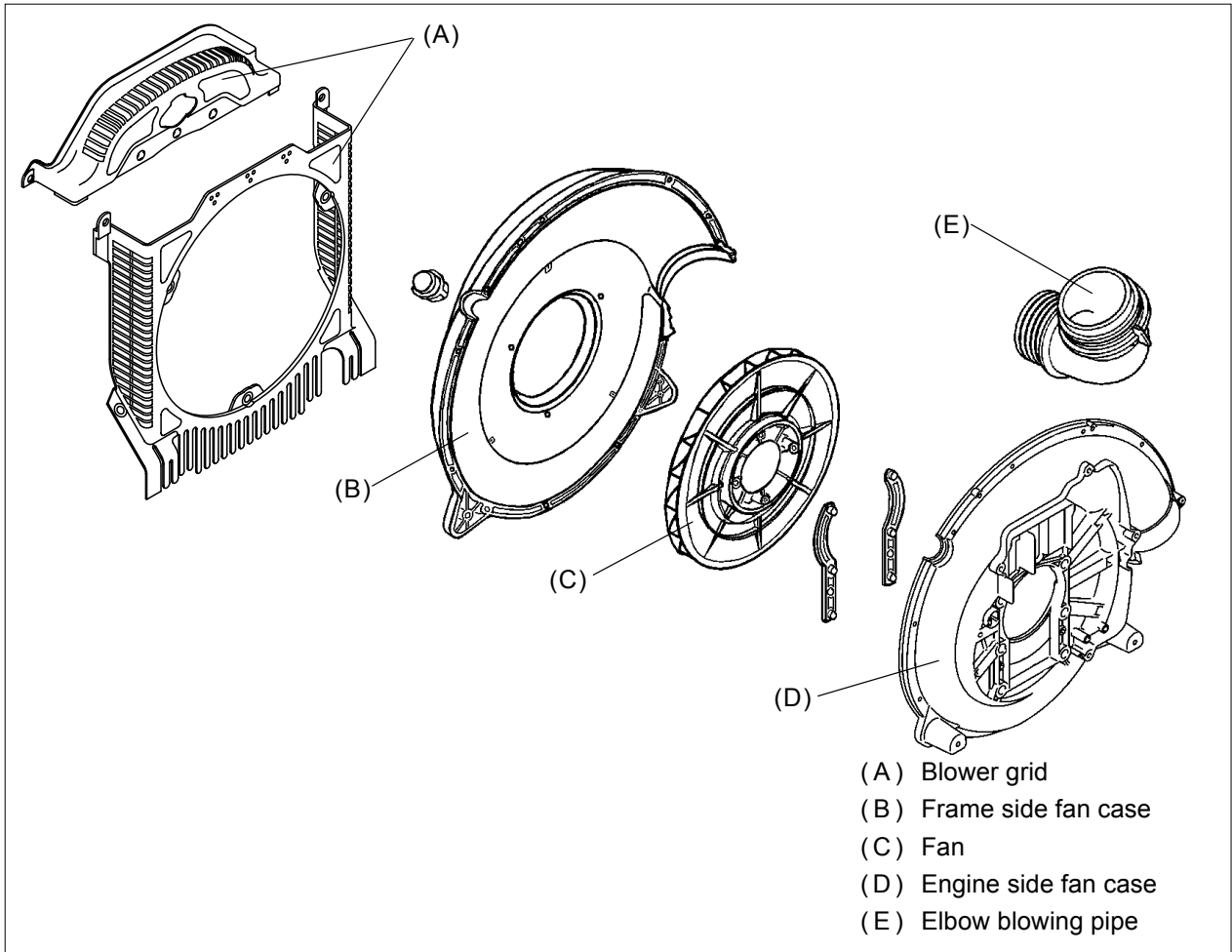

7-1 Replacing elbow blowing pipe



1. Remove spark plug and engine cover.
 2. Remove two bolts (A).
 3. Pull down elbow blowing pipe.
 4. Push a new pipe into fan case until it bottoms.
 5. Fasten bolts and nuts to install blowing pipe to the fancase.
- NOTE:** Make sure that nuts are installed in the frame side holes of fan case as the flange side of the nut faces outside.
6. Reinstall the engine cover and spark plug.

7-2 Replacing fan case grid

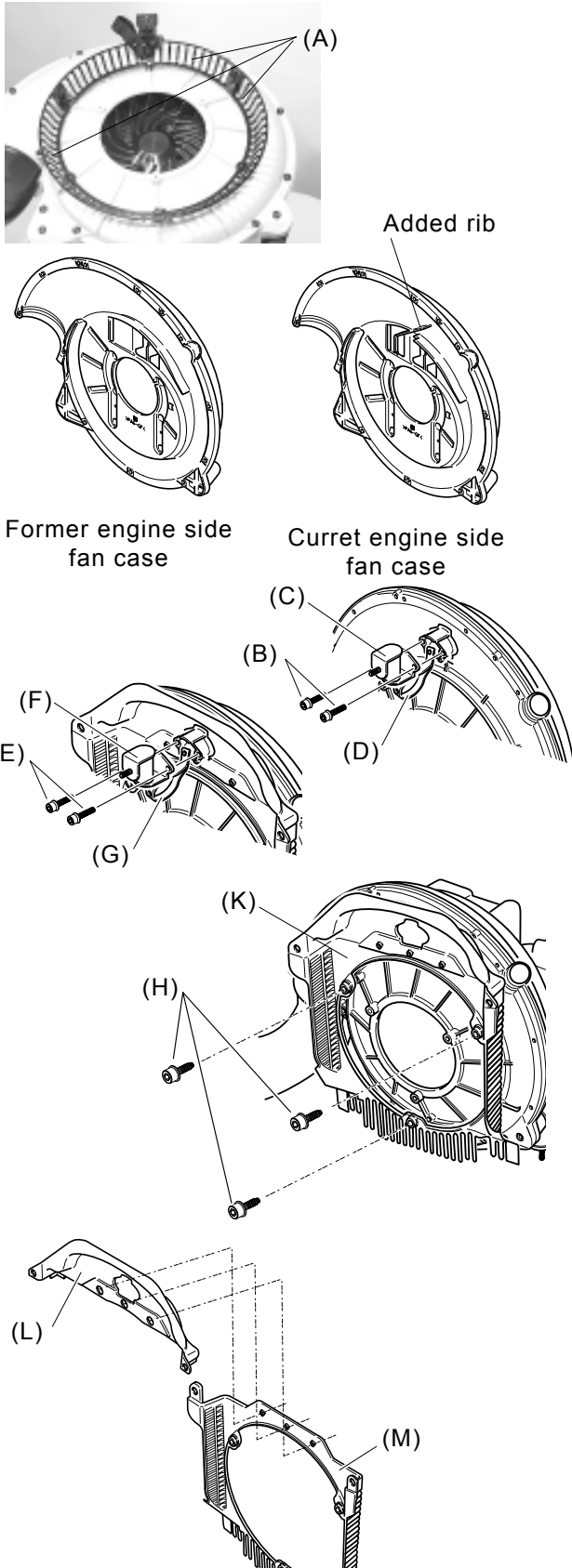

Removing blower grid

1. Remove fan case with engine block from back-pack frame (refer to 6-2 "Removing backpack frame").

For the units of PB-650 serial number up to 35003000

2. Remove former blower grid (A) from fan case.
3. Replace former engine side fan case with current engine side fan case (refer to 7-3 "Separating fan case and engine").
4. Loosen bolts (B), and remove cushion (C) and stopper (D).
5. Go to assembling blower grid below.

For the units of PB-650 serial number 35003001 to 35003140

2. Remove former blower grid (A) from fan case.
3. Loosen bolts (B), and remove cushion (C) and stopper (D).
4. Go to assembling blower grid below.

For the units of PB-650 serial number 35003141 to 35999999, and for the units of PB-750 up to 35999999

2. Loosen bolts (E), and remove cushion (F) and stopper (G).
3. Loosen three tapping bolts (H), and remove blower grid (K).
4. Separate upper piece (L) and bottom piece (M) of blower grid, and check them for crack and wear. Replace as required.

Assembling blower grid

1. Attach upper piece (L) and bottom piece (M) of current blower grid as reverse order.
2. Place current blower grid and fasten it to fan case using tapping bolts. Reinstall cushion and stopper in place.

7-3 Separating fan case and engine

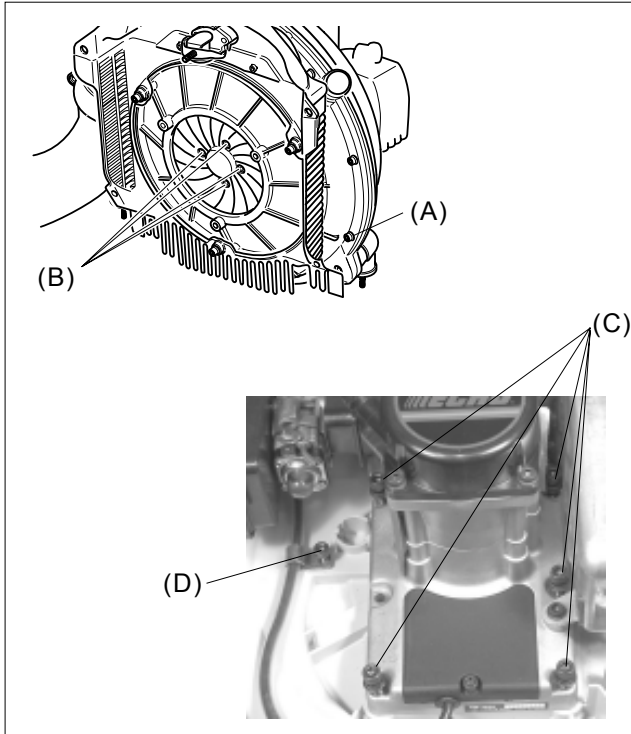

1. Remove all the tapping bolts (A) securing fan case and replace frame side fan case if defective.
2. Remove spark plug and engine cover.
3. Insert piston stopper 897537-30130 in the spark-plug hole by hand.
4. Loosen four bolts (B) of fan.
5. Remove remaining five bolts on crankcase (C) and throttle wire bracket (D) for separating engine side fan case from engine.
6. Replace fan and engine side fan case if defective.

7-4 Assembling fan and fan case

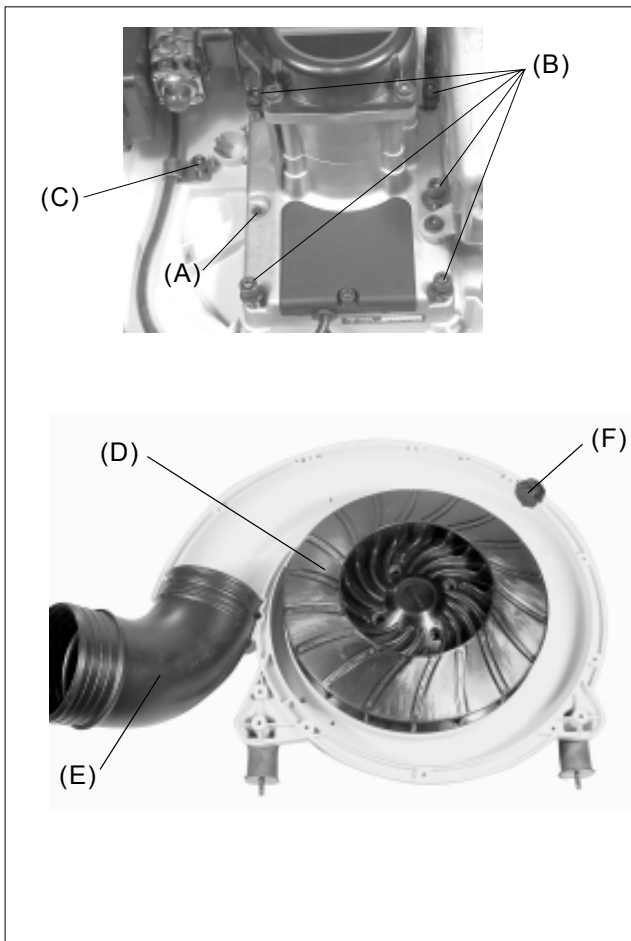

1. Put engine block on engine side fan case.

NOTE: Do not fasten the bolt on the middle left of crankcase (A) in this stage. After assembling fan case, engine, and backpack frame, this bolt is installed together with ground lead terminal of ignition switch.

2. Fasten crankcase with five bolts (B) and throttle wire bracket (C).
3. Put fan (D) on engine side fan case, and fasten it with four bolts.
4. Put elbow blowing pipe (E) and plug (F) on engine side fan case.
5. Put together frame side fan case and engine side fan case, and fasten them with tapping bolts.

NOTE: Refer to 7-1 "Fasten elbow blowing pipe".

7-5 Assembling engine unit on backpack frame

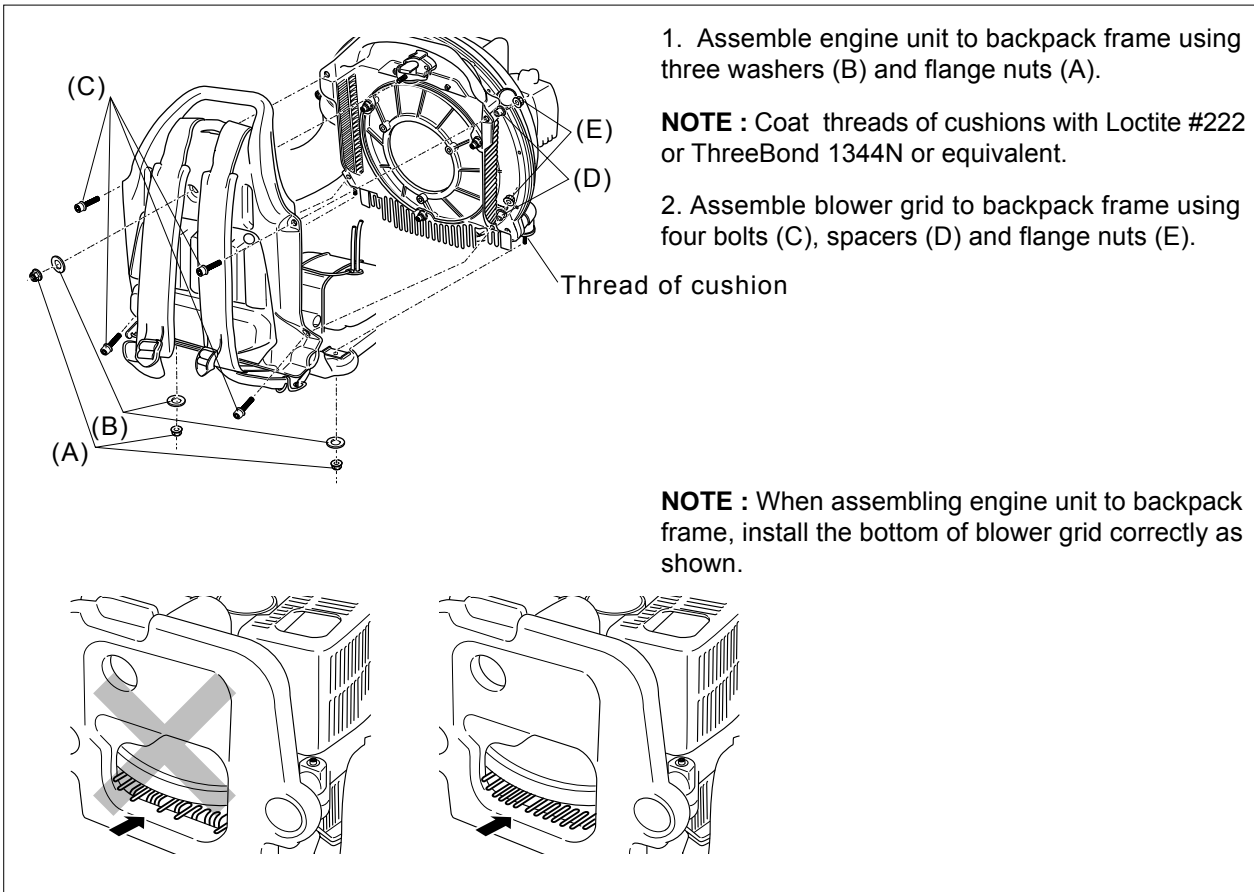

8 ENGINE

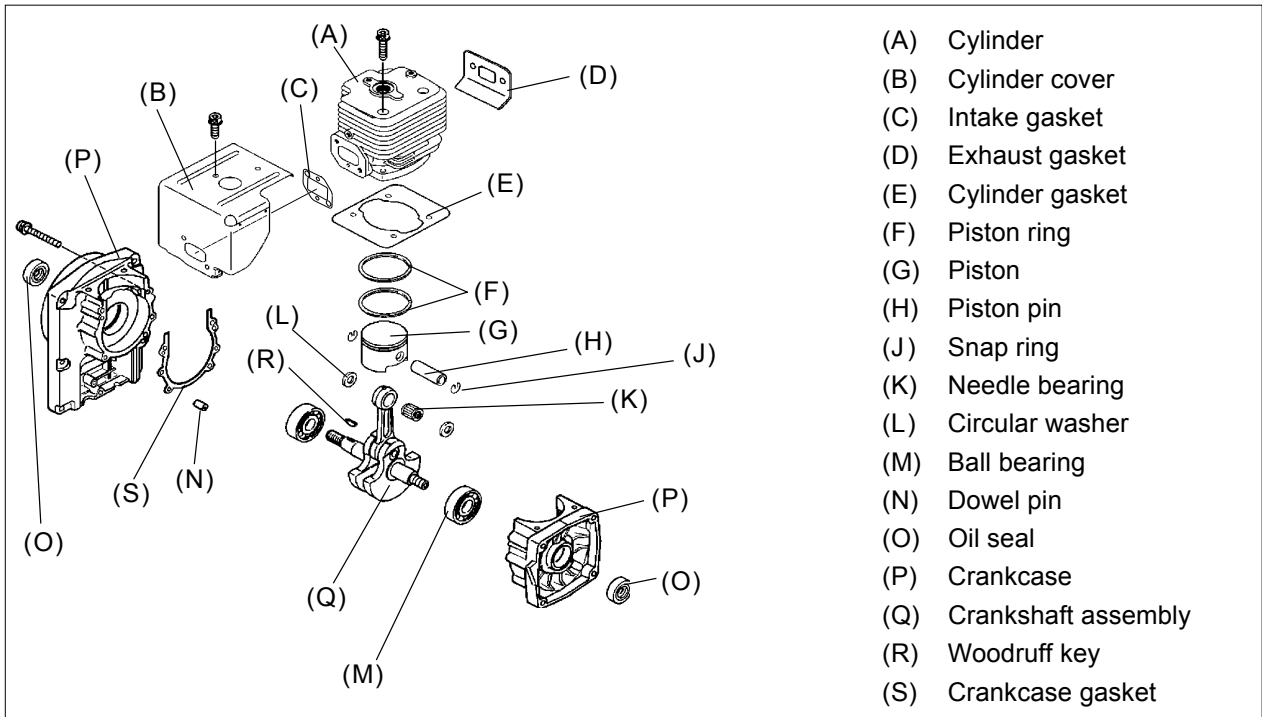

8-1 Testing cylinder compression



NOTE: Test the cylinder compression when engine is cold.

1. Move ignition switch to STOP position.
2. Remove spark plug.
3. Install a compression gauge 91007 (A) in spark plug hole as shown and pull starter several times to stabilize reading.
4. If the pressure is lower than approx. 80% of standard compression pressure, check cylinder bore, piston, and piston ring if worn-out. (Refer to "1-2 Technical data" for standard compression pressure.)
5. If the pressure is more than approx. 130% of standard compression pressure, check cylinder combustion chamber and exhaust port, piston crown, and muffler for carbon deposits.

NOTE: Compression pressure varies with the volume of compression gauge tip occupying the cylinder combustion chamber. If the volume of the gauge tip is considerably different from the one of spark plug, it is recommended to measure and note compression pressures of brand-new engines as standard pressure in advance.

6. Remove compression gauge, then reinstall spark plug and spark plug cap.

8-2 Cleaning cooling air passage



1. Remove spark plug and engine cover.
2. Inspect cylinder cooling fins for blockage with dirt or dust.



WARNING

Always wear eye protection when using compressed air. Eye damage can occur from flying particles.

3. Clean the air passages with a wooden or plastic stick, or compressed air as required.

8-3 Checking muffler and exhaust port of cylinder



1. Remove muffler.
2. Inspect the cylinder exhaust port and clean the port using a wooden or plastic stick if carbon is deposited.

NOTE: When cleaning the port, always position the piston at Top Dead Center (TDC) to prevent carbon from entering cylinder. Do not use a metal tool and be careful not to scratch piston or cylinder.

3. Remove carbon deposits from muffler component parts. If heavily deposited, replace with new parts as required.
4. Reinstall all the removed parts in place.

8-4 Testing crankcase and cylinder sealings

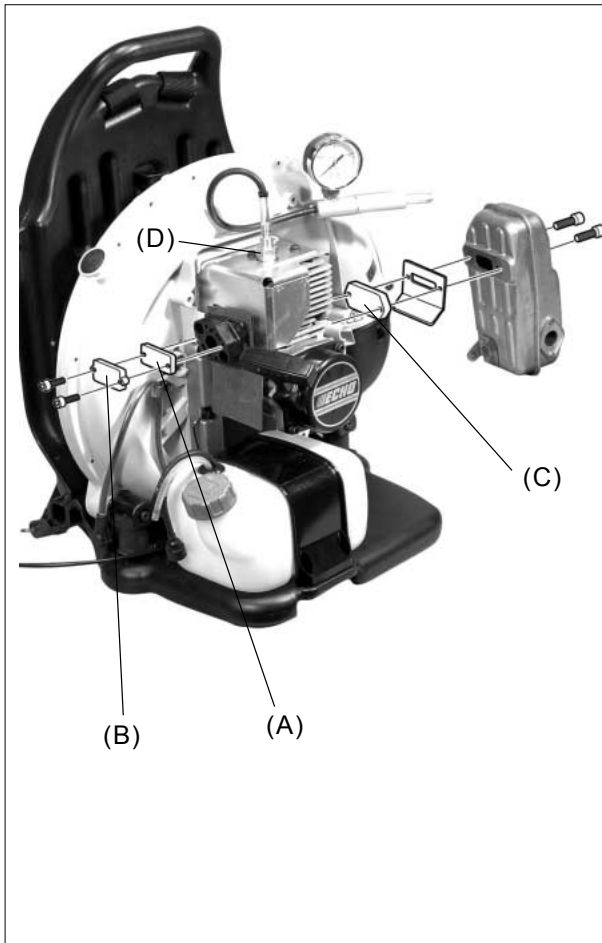

1. Remove muffler and carburetor.
2. Close Intake port and crankcase pulse passage using pressure plug 897826-16131 (A), pressure plate 897827-16131 (B).
3. Close exhaust port with pressure plug 897834-79930 (C), and install muffler.
4. Install pressure connector 897833-16131 (D) to spark plug hole.
5. Connect pressure tester to connector and apply approx. 0.2 kgf/cm² (3 psi) of pressure.

NOTE: Do not exceed 0.5 kgf/cm² (7 psi), or damage to seals will result.

6. Gauge should indicate constant pressure at a minimum of 0.2 kgf/cm² (3 psi).

NOTE: Leak less than the value of 0.05 kgf/cm² (1 psi) per minute is allowed.

7. If the reading drops, use soapy water to locate leakage. Leakage may occur from the cylinder base, crankcase seam, or oil seal.

8. Remove plugs from exhaust port and Intake port after this test, and reinstall all the removed parts in place.

8-5 Checking cylinder

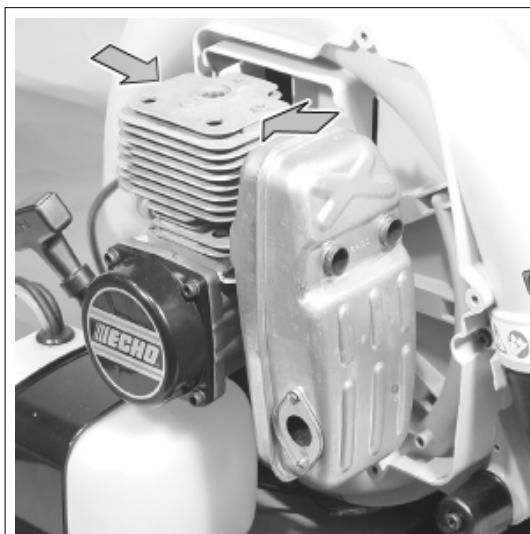

1. After removing cylinder cover and insulator, remove cylinder from engine.

NOTE: If it is difficult to remove cylinder, gently tap cylinder with a plastic mallet at carburetor and/or muffler sides of cylinder head.

2. Inspect the cylinder combustion chamber. Clean with wooden or plastic scraper if carbon is deposited.

NOTE: Never use a metal scraper in the cylinder combustion chamber to avoid damage.

3. Replace the cylinder with a new one if plating is worn, peeled away or scored, exposing cylinder base metal.

8-6 Removing flywheel

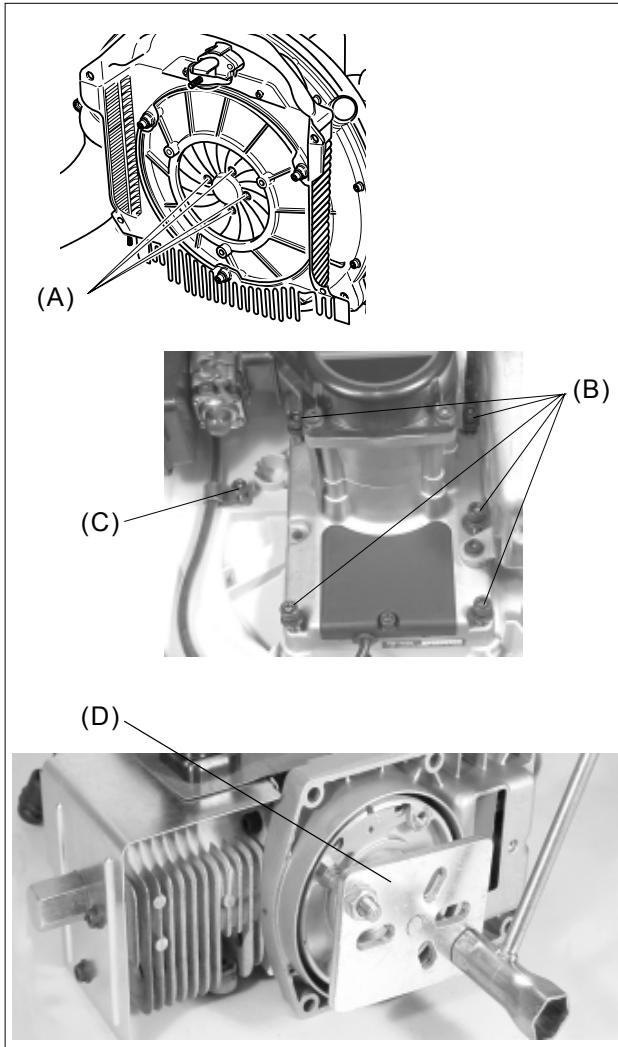

1. Remove fan case with engine block from backpack frame (refer to 6-2 "Removing backpack frame").
2. Remove spark plug and engine cover.
3. Insert piston stopper 897537-30130 in the spark plug hole by hand.
4. Loosen four bolts of fan (A).
5. Remove remaining five bolts (B) and throttle wire bracket (C) on crankcase
6. Separate engine block from fan case.
7. Remove nut securing flywheel to crankshaft.

NOTE: Do not pry flywheel from crankshaft. Damage will result to crankshaft, flywheel or other main parts of engine.

8. Install puller 897501-03938 (D) on flywheel.
9. Tighten two nuts on stud alternately with even strength to remove flywheel.
10. Remove piston stopper.

8-7 Checking woodruff key for flywheel

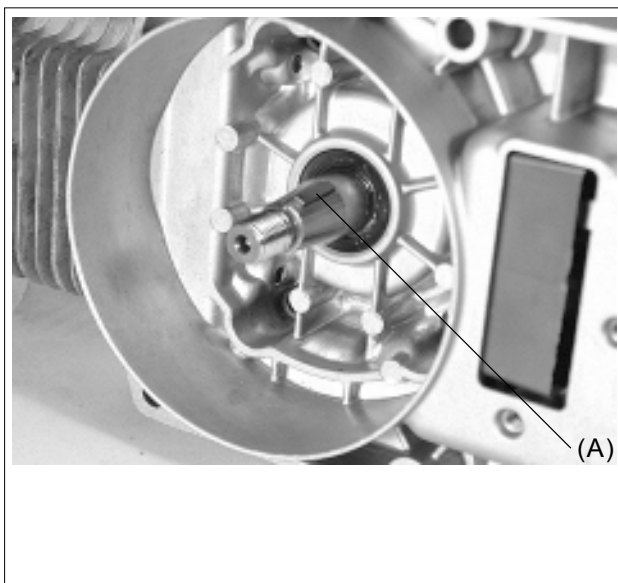

1. Check Woodruff key (A) on crankshaft if defective. Replace as required .
2. When installing woodruff key on crankshaft, set the key in parallel with center line of crankshaft.

8-8 Installing flywheel

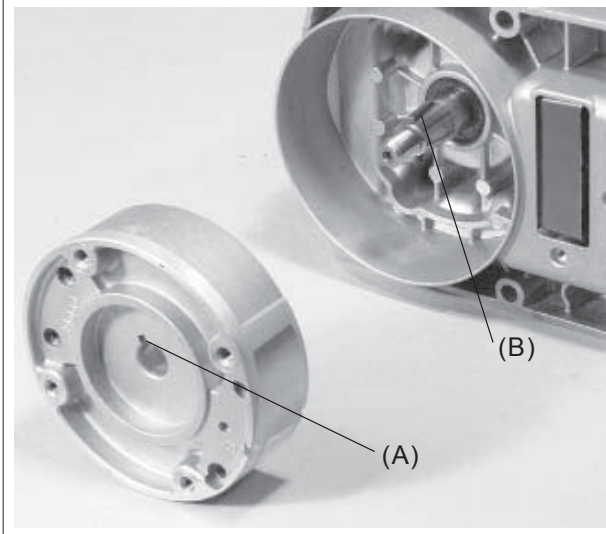

1. Install flywheel matching key way (A) of flywheel to key (B) on crankshaft. Tighten nut by hand.

NOTE: If starter is installed, pull starter rope out about 20 cm (8 in) and make a temporary knot at the end of rope guide before inserting piston stopper in spark plug hole. After inserting piston stopper, pull out starter handle and untie temporary knot. Rotate flywheel counterclockwise until it stops at piston stopper. Then release rope.

2. Insert piston stopper 897537-30130 in the spark plug hole by hand.

3. Install the nut to flywheel and tighten it.

4. Reinstall all the parts, which have been removed,

8-9 Checking piston and piston ring

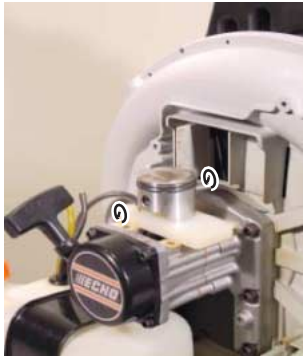
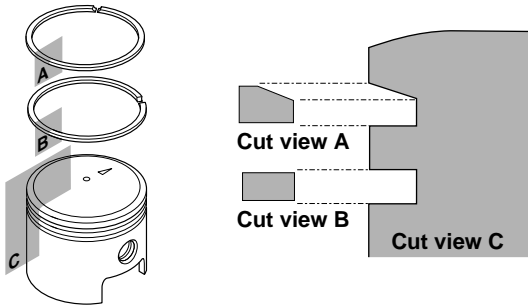

1. Clean the piston crown with a fine sandpaper or wooden scraper as required.

2. After removing piston rings, clean the ring groove using a ring groove cleaning tool.

NOTE : Do not use the squared end of broken piston ring when cleaning the 1st piston ring groove of PB-650 and PB-750, because the 1st piston ring is **key-stone ring** and the 1st ring groove is trapezoid shape to meet the key-stone ring.

If clean the 1st ring groove using the end of broken piston ring, 1st ring groove might be scratched.

3. Check the piston and piston rings for wear or heavy discoloration. Replace as required.

4. Remove piston pin circlips from the piston and discard them.

5. Push the piston pin out from the piston.

NOTE: If the piston pin is tight, use the piston pin tool 897702-30131 (A) with the adapter stamped "10" on an end and piston holder 897719-02830 (B).

6. Check the piston pin and needle bearing for wear or discoloration. Replace as required.

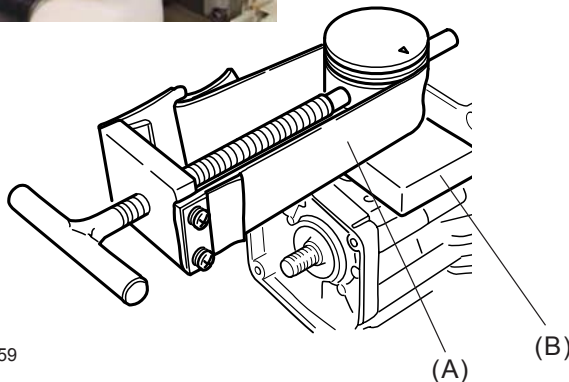

1K359



8-10 Disassembling crankcase

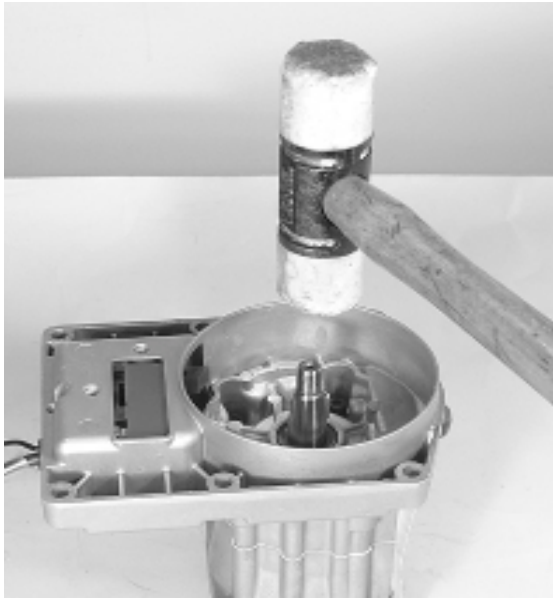

1. Remove four bolts securing the crankcase.
2. Remove woodruff key from crankshaft to avoid damage of oil seal.
3. Hold the crankcase half and tap crankshaft end using a plastic mallet to separate the crankcase halves.
4. Hold the other crankcase half and tap the end of crankshaft to remove crankshaft.
5. Clean the insides of crankcase halves if dirty. Replace as a set if damaged.
6. Inspect the crankshaft for roughness (crankshaft runout), discoloration, or other damage. Replace it with a new one as required.

8-11 Removing main ball bearing and oil seal

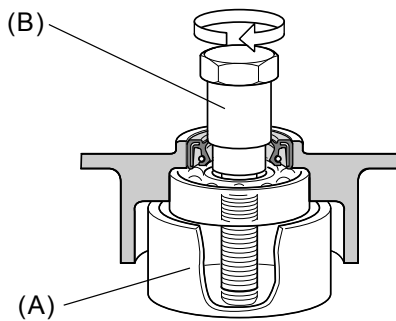

1. Check the ball bearings for smooth rotation. If rough, replace it (them) with new ones.

2. Remove the main ball bearing from crankcase half using the bearing tool set 897701-14732 as shown.

To remove ball bearing from crankcase half smoothly:

- 1) Hold nut (A) using vice firmly.
- 2) Tighten bolt (B) using wrench to remove the bearing.

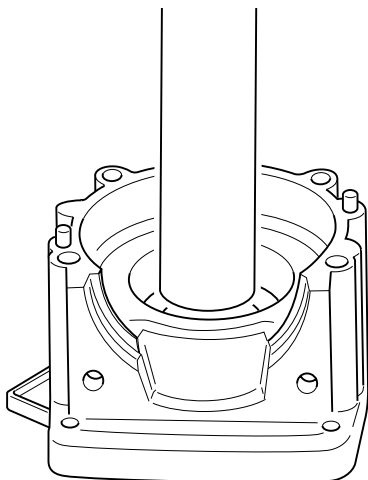

3. Push out oil seal using oil seal tool 897726-21430.

NOTE : Remove the oil seal after removing main ball bearing, because the oil seal is tight fitting.

4. Clean up inside of crankcase.

8-12 Assembling main ball bearing

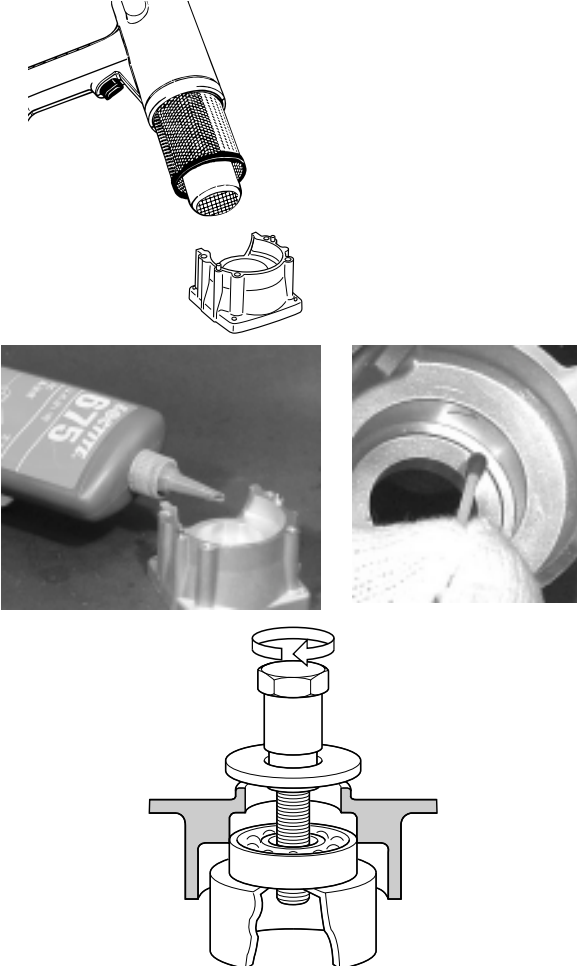

1. Heat bearing housing of crankcase to 110°C (230°F) for easier installation of main ball bearing.
2. Apply thin coating of Loctite #675 in circumference of the bearing housing. Do not apply the Loctite too much, or the Loctite flows inside the ball bearing and damage the bearing.

NOTE : After applying Loctite, move next process quickly, because the Loctite would be dried by heated crankcase.

3. Insert ball bearing using bearing tool set 897701-14732 without inclining the ball bearing as shown.

8-13 Assembling crankshaft and crankcase

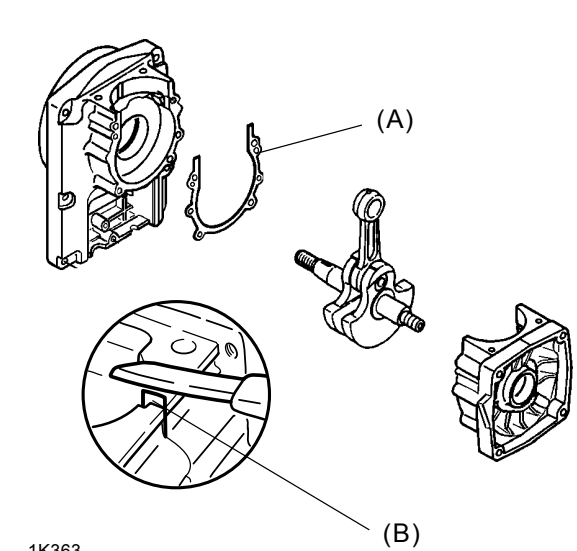

1. Clean the mating surface of each crankcase half.
2. Insert the crankshaft starter end into the starter side of the crankcase half until properly seated. If hard to insert, gently tap at the other end with a plastic mallet.
3. Put a new crankcase gasket (A) on the fan case side crankcase half.
4. Reassemble both crankcase halves together ensuring that dowel pins on the crankcase half are properly seated in holes another half.
5. Tighten four bolts to secure the crankcase halves together and check crankshaft rotation.

NOTE: The torque differences among four bolts should not exceed 20kgf•cm(17in•lbf).

6. Remove an excessive protruding portion of crankcase gasket (B) with a sharp knife carefully.

1K363

8-14 Assembling oil seal

Dust lip Seal lip

Oil seal section

(B)

(A)

1mm

1. Apply lithium based grease on dust lip and seal lip of oil seal to avoid damage of lips while inserting crankshaft into the oil seal.
2. Lubricate the circumference of oil seal with alcohol or thinner.
3. Push oil seal (A) down 1 mm from boss edge using oil seal tool 897726-21430 (B) for both starter side seal and fan side seal.
4. Install woodruff key on magneto rotor side crankshaft.

8-15 Assembling piston rings on piston

(1)

(2)

(3)

Cut view (1)

Cut view (2)

Cut view (3)

(A)

(B)

(C)

(D)

NOTE : The 1st piston ring and the 2nd piston ring are not interchangeable. If the 2nd piston ring is installed in 1st ring groove, cylinder can not be assembled on the piston.

1. Assemble the 2nd ring (A) firstly, while meeting ring-ends with locating pin of the 2nd ring groove (B).
2. Assemble 1 st ring (key-stone ring) (C), while meeting ends of 1st ring with locating pin of the 1st ring groove (D).

NOTE : In case of assembling the key-stone ring without meeting the ends with the locating pin and rotated the ring to meet with the locating pin after assembling the ring, the ends might scratch on the groove as shown. If the scratch is made, friction of piston-movement becomes bigger.

8-16 Installing piston

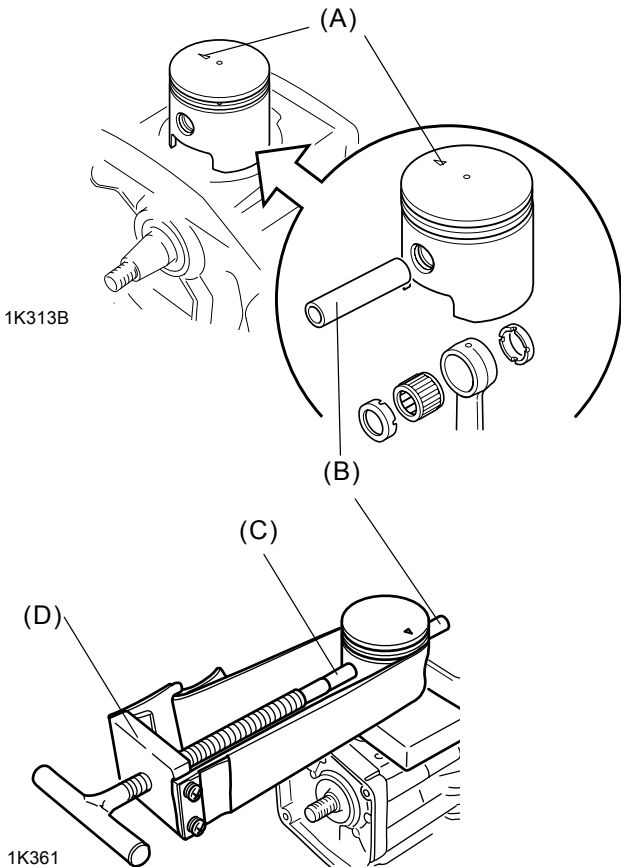

1. Lubricate needle bearing with the two-stroke oil.

2. Insert needle bearing into the small end bore of connecting rod.

3. Place piston over the small end of connecting rod, so that the arrow mark (A) on piston points toward the exhaust side.

4. Insert piston pin guide (B) stamped "10", through Piston, washers and needle bearing in connecting rod.

5. Insert piston pin (C) in piston pushing out piston pin guide (B) using piston pin tool 897702-30131 (D).

6. Install new snap rings to the piston pin bore, and be sure that they are properly seated in the grooves.

8-17 Installing cylinder

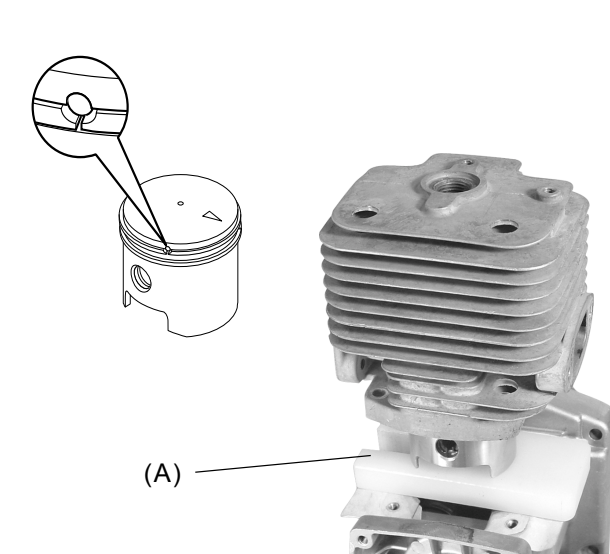

1. Stick a new cylinder gasket on the cylinder base with a little glue for easier installation of the cylinder.

2. Make sure the piston ring on the piston ensuring that the locating pins are positioned between the ring ends.

3. Apply oil to the piston ring and cylinder internal wall.

4. Install the cylinder over piston ensuring that exhaust side of cylinder is at arrow side of piston.

NOTE: When installing piston, it is convenient to use a piston holder 897719-02830 (A) for stabilizing the piston.

NOTE: Do not rotate the cylinder while installing. Otherwise, the piston ring and/or cylinder wall might be damaged.

9 MAINTENANCE GUIDE

9-1 Troubleshooting guide

TROUBLE	
Engine does not crank.	01
Engine does not start.	02
Fuel leaks.	03
Idling is not stable.	04
Acceleration is poor.	05
Engine stalls at high speed.	06
Engine lacks power.	07
Engine overheats.	08
Engine misfires.	09
Engine / others are extremely noisy.	10
Fuel consumption is excessive.	11
Vibration is excessive.	12
Engine does not stop.	13
Staic electricity	14

CHECKING	REFERENCES	14	13	12	11	10	09	08	07	06	05	04	03	02	01	Check <input type="radio"/> first.
Starter system		14	13	12	11	10	09	08	07	06	05	04	03	02	01	
Rewind spring	2-3															<input type="radio"/>
Starter pawl / spring	2-6															<input checked="" type="radio"/>
Ignition system		14	13	12	11	10	09	08	07	06	05	04	03	02	01	
Sparks	3-2						<input checked="" type="radio"/>			<input type="radio"/>	<input type="radio"/>	<input type="radio"/>			<input checked="" type="radio"/>	
Spark plug	3-3						<input type="radio"/>			<input type="radio"/>	<input type="radio"/>	<input type="radio"/>			<input type="radio"/>	
Spark plug cap / coil	3-4						<input type="radio"/>								<input type="radio"/>	
Ignition switch	3-6, 3-10		<input checked="" type="radio"/>				<input type="radio"/>								<input type="radio"/>	
Ignition coil	3-5, 3-7,3-8						<input type="radio"/>			<input type="radio"/>	<input type="radio"/>	<input type="radio"/>			<input type="radio"/>	
Pole shoe air gaps	3-9						<input type="radio"/>		<input type="radio"/>			<input type="radio"/>			<input type="radio"/>	
Flywheel	3-7,3-9						<input type="radio"/>					<input type="radio"/>			<input type="radio"/>	
Flywheel key	8-7								<input type="radio"/>			<input type="radio"/>			<input type="radio"/>	
(Continued)																

9-2 Service Intervals

Check point	Service	Reference	Intervals			
			Daily	weekly or monthly	3 months or 100 hours	Yearly or 600 hours
Screws, bolts, and nuts	Inspect / Retighten / Replace		○			
Air filter	Clean	4-1, 4-12	○			
	Replace				○	
Carburetor	Inspect / Rebuild	4-4 to 4-11			○	
	Replace					○
Fuel leaks	Inspect / Repair	4-4	○			
Fuel line	Inspect / Repair	4-5, 4-6			○	
Choke system	Inspect / Clean / Replace		○			
Cooling system	Inspect / Clean	8-2	○			
Spark plug	Clean / Regap	3-3		○		
	Replace				○	
Fuel strainer	Clean / Replace	4-2		○		
Leads and connections	Inspect / Repair				○	
Fuel tank	Clean inside.			○		
Muffler and exhaust port	Clean	8-3		○		
Starter rope	Inspect / Clean	2-2, 2-4	○			

Daily: Checking in every services.

IMPORTANT: Service intervals shown above are maximum. Actual use and your experience will determine the frequency of required maintenance.

9-3 Disassembly chart

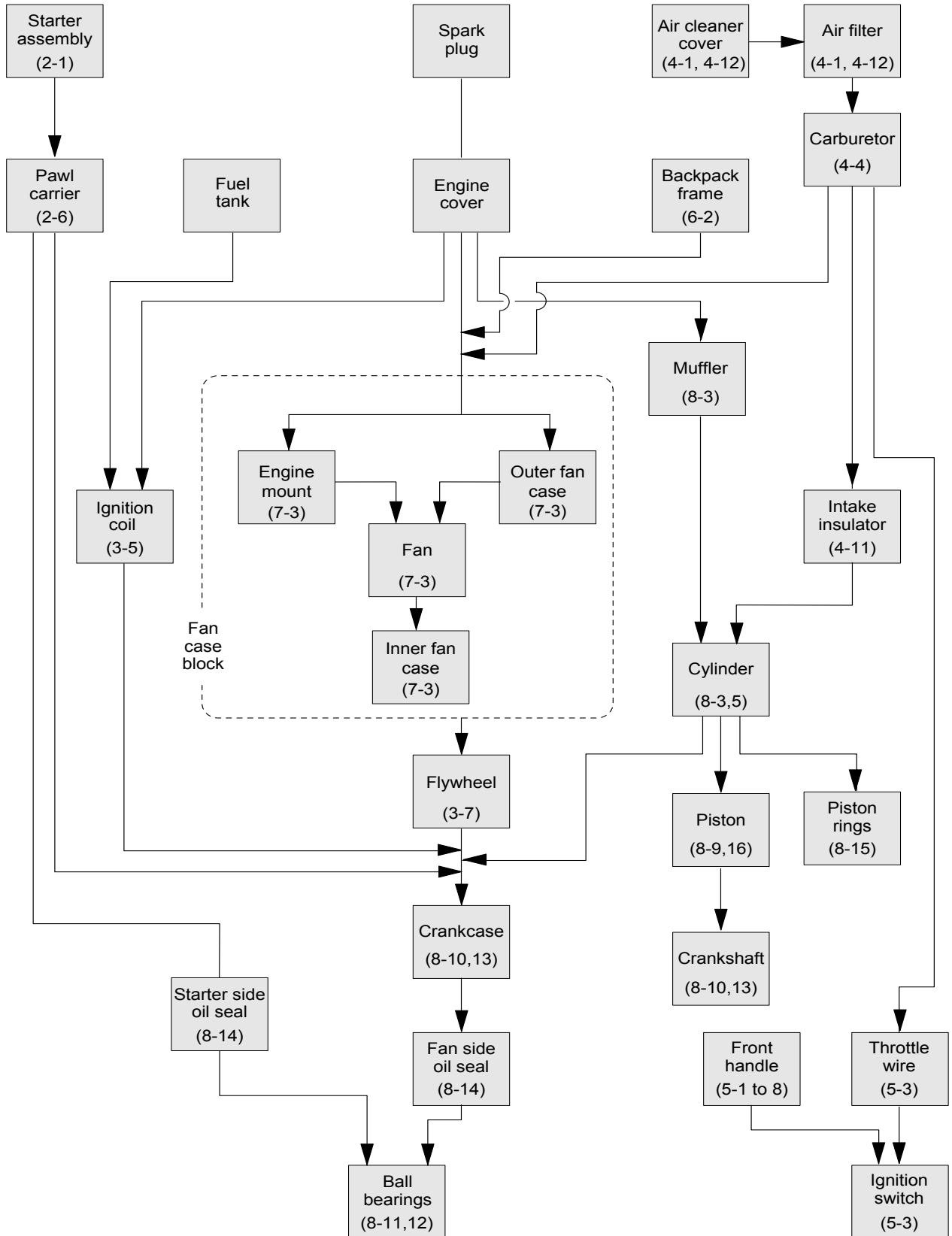

- Adapter, piston pin tool 7, 39,43
Air filter 19,25
Ball bearing, crankcase 40, 41
Bearing tool 7, 40
Carburetor 20 to 24
Carburetor adjustment 20
Carburetor pressure test 21
Check main jet 24
Coil resistance 15
Compression pressure 3, 35
Cooling air passage 36
Crankcase 35, 37, 40, 41
Crankcase / Cylinder sealings 37
Crankcase pulse passage 25
Crankshaft 41
Crankshaft runout 6
Cylinder 35, 36, 37
Cylinder bore 6
Cylinder compression 3, 35
Cylinder fins 36
Diaphragms, carburetor 24
Disassembly chart 47
Engine 35 to 43
Exhaust port 36
Fan 31
Fan case 31 to 34
Fan case grid 32
Flywheel 16, 38
Fuel cap 19
Fuel lines 22
Fuel strainer 18, 19
Fuel system 18 to 25
Fuel tank 18, 19, 22
Fuel tank vent 22
Gasket, carburetor diaphragm 24
Gasket, crankcase 40, 41
Gasket, fuel cap 19
Grommet, fuel tank 22
Heavy duty air cleaner kit 25
High tension lead 15
Idling (idle) speed 3, 20
Ignition coil 15, 16, 17
Ignition switch 16, 27
Ignition system 13 to 17
Ignition timing 3
Inlet needle valve 23
Intake insulator 18, 25
Key, flywheel 38, 39
Key-stone ring 39
L-wrench 7
Lead, ignition switch 16, 27
Magneto wrench 7,17
Maintenance guide 44 to 45
Metering lever 7, 23
Metering lever height 3, 23
Minimum secondary voltage 3
Muffler 36, 37
Oil seal, crankcase 42
Oil seal tool 14, 42
Pawl carrier 12
Pin guide, piston pin tool 7, 43
Piston 35, 39, 42, 43
Piston outer diameter 6
Piston pin bore 6
Piston pin outer diameter 6
Piston pin tool 7, 39, 43
Piston ring 39, 42, 43
Piston ring end gap 6
Piston ring groove 6, 39
Piston ring side clearance 6
Piston ring width 6
Piston stopper 7,12
Pole shoe air gaps 3,17
Pressure connector 7, 36
Pressure tester 7,21,22,36
Purge pump 21,24
Rewind spring 8,10
Rope guide 10,11
Rope tension 12
Secondary coil resistance 3,15
Service information 2 to 7
Service intervals 46
Service limits 6
Spark plug 2,14
Spark plug cap 15
Spark plug cap coil 15
Spark plug gap 3,14
Spark test 14
Spark tester 7,14
Special tools 7
Specifications 2
Starter center post 10,11
Starter drum 9,11,12
Starter grip 9,11
Starter pawl 12
Starter rope 9,11,12
Starter system 8 to 12
Static protection kit 28
Tachometer 7,20
Technical data 3
Test pressure, carburetor 21
Thread locking sealant 4, 5
Torque limits 4
Troubleshooting guide 44 to 45
Troubleshooting guide, ignition 13
Wooden stick 35

ECHO[®]



KIORITZ CORPORATION

TOKYO JAPAN

Printed in Japan

0406