

# STIGA

## WBE 120 - 140

# WORKSHOP MANUAL

Rel. 0.0



PRODUCTION YEAR 2019 - 2021

The manufacturer reserves the right to make all the necessary technical or commercial improvements to its products, so there may be some differences between the series of engines and the contents of this manual. However the basic specifications and different operating procedures will remain the same.

by STIGA - No use of the illustrations or duplication, reproduction or translation, even partial, of the texts in this document may be made without explicit authorization.

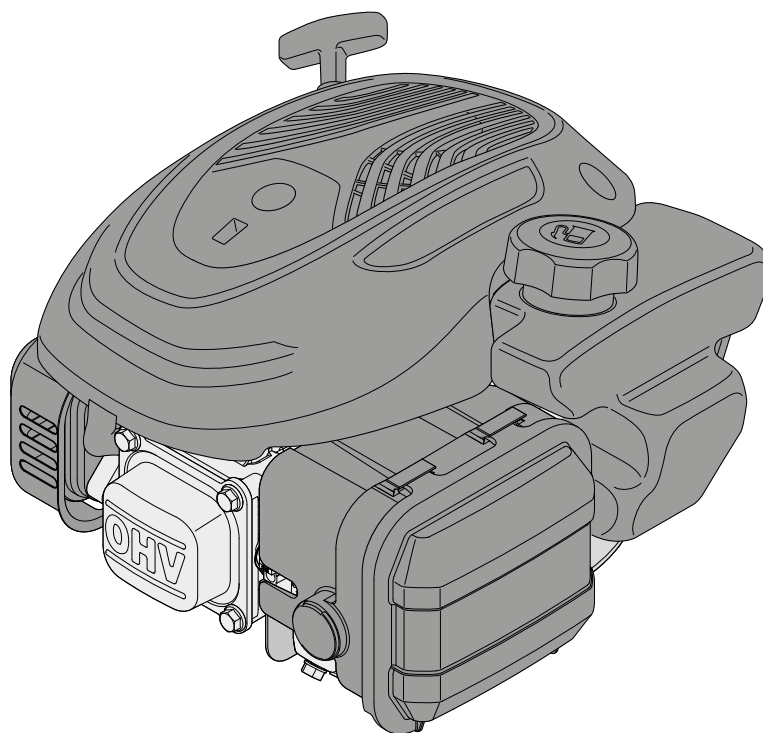

**IMPORTANT NOTICE :** The information contained herein is intended for Service Operations and professionals only, able to competently perform the operations described herein, using the appropriate equipment in order to safeguard se-curity and performance of the machine. The manufacturer is not liable for damages or injuries arising from operations performed by individuals or inadequate facilities.





**CONTENTS**

**INTRODUCTION..... 5**

**1. RULES AND PROCEDURES FOR SERVICE CENTRES ..... 6**

    1.1. Guarantee validity .....6

    1.2. Service repairs after guarantee period.....6

    1.3. Fault notification .....6

    1.4. Spare parts request.....6

**2. GENERAL AND SAFETY REGULATIONS..... 7**

    2.1. Qualification of operators .....7

    2.2. Safety measures .....7

    2.3. Precautions during servicing.....7

    2.4. Warning labels.....8

    2.5. Necessary equipment .....8

    2.6. Symbols and terms used for safety purposes.....8

**3. TECHNICAL DATA AND SPECIFICATIONS..... 9**

    3.1. Identification.....9

    3.2. Technical data .....9

    3.3. Adjustments .....9

    3.4. Expendable materials.....9

    3.5. Use limits.....9

    3.6. Tightening torques.....10

    3.7. Table of Tightening torques .....11

    3.8. Identification of engine units.....12

**4. ENGINE TUNING AND TESTING ..... 13**

    4.1. Operating guidelines .....13

    4.2. Engine tuning program.....13

    4.3. Functional test .....14

**5. TANK AND SUPPLY ..... 15**

    5.1. Emptying and removing the tank.....16

    5.2. Cleaning the tank .....16

    5.3. Checking and cleaning the breather pipe .....17

**6. STARTING SYSTEM..... 18**

    6.1. Removing the starter assembly .....18

    6.2. Replacing the rope .....18

    6.3. Replacing the hooks.....19

**7. INTAKE SYSTEM ..... 20**

    7.1. Servicing and replacing the sponge filter element.....20

**CONTENTS**

<b>8. CARBURATION.....</b>	<b>22</b>
8.1. Removing and cleaning the carburettor .....	22
8.2. Replacing the carburettor .....	25
8.3. Adjusting speed .....	25
8.4. Adjusting the carburation.....	25
<b>9. GOVERNOR SYSTEM OF THE CARBURETTOR .....</b>	<b>26</b>
9.1. Adjusting speed .....	26
<b>10. AUTO-CHOKE SYSTEM.....</b>	<b>28</b>
10.1. Replacing of the AUTO-CHOKE system.....	28
<b>11. IGNITION.....</b>	<b>29</b>
11.1. Checking the efficiency of the ignition system .....	29
11.2. Adjusting the air gap and checking the coil .....	30
11.3. Replacing the coil.....	31
<b>12. TURNING OFF AND STOPPING THE ENGINE .....</b>	<b>32</b>
12.1. Checking the control cable.....	32
12.2. Checking the system for turning off the engine.....	32
12.3. Checking the brake.....	33
12.4. Replacing the system for turning off and stopping the engine .....	34
<b>13. EXHAUST SYSTEM .....</b>	<b>35</b>
13.1. Removing and replacing the muffler .....	35
<b>14. ENGINE BLOCK - External operations .....</b>	<b>36</b>
14.1. Checking the heating unit seal .....	36
14.2. Adjusting the valve clearance .....	37
14.3. Dismantling and replacing the flywheel.....	38
14.4. Blow-by check .....	39
14.5. Replacing the upper compression ring of the engine shaft (flywheel side) .....	39
14.6. Replacing the lower compression ring of the engine shaft (sump side).....	40
<b>15. ENGINE BLOCK - Overhauling internal parts.....</b>	<b>41</b>
15.1. Carter opening .....	41
15.2. Dismantling and checking the camshaft and counterweight governor.....	42
15.3. Dismantling and checking the piston, piston rings, connecting rod and engine shaft.....	44
15.4 Overhauling the valves .....	50
<b>16. TROUBLESHOOTING .....</b>	<b>53</b>

### INTRODUCTION

The purpose of this manual is to provide to Service Centres the information necessary for a correct maintenance, dismantling and repair procedure for the **engines WBE 120 and WBE 140**.

Interventions on the engine must be performed in accordance with instructions in the following pages and with safety regulations in force in the country in which the engine is operated, and only by authorised and appropriately trained personnel.

In every manual page the following informations are described:

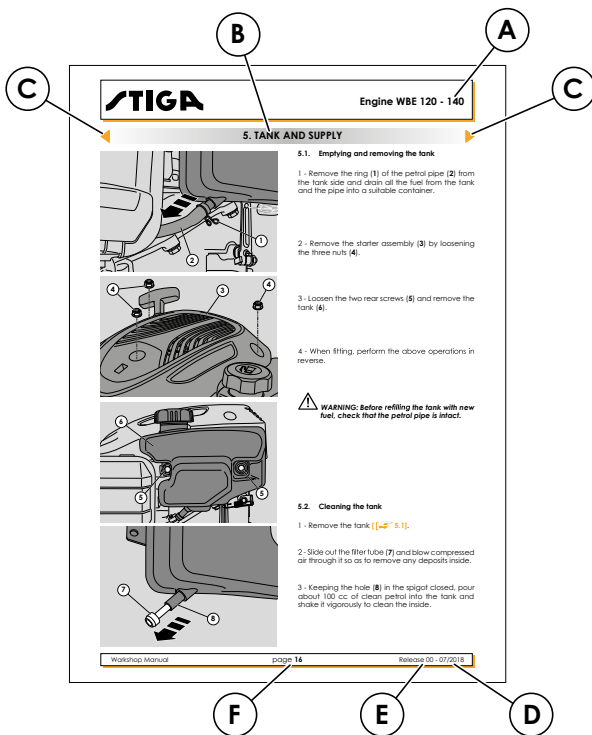

- A:** Motor typ for which the page is valid.
- B:** Reference to the chapter and the argument with the relative numbering.
- C:** Presence of previous or following chapters from the present chapter.
- D:** Issue date or possible audit.
- E:** Audit number.
- F:** Page progressive numbering.

Certain symbols are used in the manual, highlighting particularly important information, risks, warnings and prescriptions:



**Warns of operations that should be carried out with utmost care to avoid impairing the functionality and safety of the lawnmower.**



**Warns of operations that should be carried out with utmost care to avoid injury to the operator.**



**NOTE: Refers to specific advice by the manufacturer.**



**Reference to another procedure or part of the manual.**



**Recommends that washers and O-rings are checked and replaced if necessary.**



**Refers to use of special tools.**



**Shows all the operations requiring different intervention methods depending on the engine version.**



**NOTE: During the description of procedures, the indications "right", "left", "front", "rear", "upper" and "lower" refer to the engine mounted on the lawn tractor seen from the user's perspective.**

Please read all the contents of this manual to become familiar with the basics of the engine, which is fundamental for operating in a logical manner without making errors or wasting time.

## 1. RULES AND PROCEDURES FOR SERVICE CENTRES

### 1.1. Guarantee validity

The warranty is supplied under the terms, procedures and limits stated in the contract.

### 1.2. Service repairs after guarantee period

The Service Centre must write a report for each intervention containing the serial number of the engine  **3.1**, and summary information about the problems complained of, the intervention made and possible spare parts used..

A copy of these reports must be kept and made available to the manufacturer together with the replaced parts, in case clients should make further complaints.

### 1.3. Fault notification

The manufacturer should be informed of all faults that recur frequently; this allows it to carefully examine the problem and make corrections on the production line.

Similarly, the manufacturer shall report any faults traced on its engines, indicating the best troubleshooting procedure.

### 1.4. Spare parts request

When asking for spare parts, you must quote their code by referring to the exploded views corresponding to the year of manufacture reported on the nameplate  **3.1**.

## 2. GENERAL AND SAFETY REGULATIONS



**IMPORTANT:** Before commencing with any intervention, carefully read the information provided in the present manual, in particular the following safety regulations.

### 2.1. Qualification of operators

All maintenance, disassembly and repairs must be carried out by expert mechanics who are familiar with all the accident prevention and safety regulations after reading through the procedures in this manual.

### 2.2. Safety measures

All the engines are built in conformity with the European safety regulations in force. To maintain initial safety levels in the long term, the Service Centre should take proactive measures by making checks whenever possible. Every time you are asked to service the engine (or the lawnmower on which it is installed), you should:

- check:
  - that the safety devices function correctly;
  - that the casings and protection covers have not been removed;
  - that the nameplates or specification labels have not been removed or made illegible, (as they form an integral part of the safety devices).
- also:
  - restore to proper working order any safety devices which have been manipulated or removed;
  - replace ineffective, damaged or missing guards and covers;
  - replace illegible labels;
  - do not carry out operations or modifications on the lawnmower or on the engine that could affect their performance or lead to an improper or different use from the one for which it has been designed and approved;
  - warn the customer that the failure to comply with the above points automatically voids the warranty and the responsibility of the manufacturer.

### 2.3. Precautions during servicing

As well as following the usual accident prevention regulations that apply to most repair shops, we recommend you:

- disconnect the spark plug cap before servicing;
- protect hands with suitable working gloves, especially when working near the cutting unit;
- check that you do not cause accidental petrol leaks or other losses;
- do not smoke when working on the tank or when handling petrol;
- do not inhale oil or petrol fumes;
- clean up all traces of spilt petrol immediately;
- do not pollute the environment with oil, petrol or other waste and dispose of all waste in accordance with the laws in force.



**Exhaust gas contains carbon monoxide, which is highly toxic, odourless and colourless. Avoid inhaling.**

- Perform tests on the engine in a well-ventilated environment or in the presence of adequate exhaust gas extraction systems.

## 2. GENERAL AND SAFETY REGULATIONS

### 2.4. Warning labels

On the canopy motor, in a immediately identification position, are some indication or prescription plates for the safety operator.

The plates are as follows:

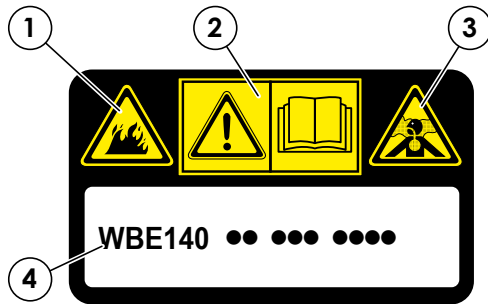

#### 1 - Fire hazard due to:

##### - Petrol or oil

Prevent by following the precautions below:

- Do not smoke or ignite a flame in the vicinity of the petrol or oil;
- Turn engine off before adding petrol;
- Do not spill petrol on overheated or electric parts of the engine;
- Handle or store petrol or oil in well-ventilated areas;
- Use non-flammable oil for cleaning engine parts.

##### - Accumulation of flammable material

Prevent by following the precautions below:

- Remove dry leaves, chips, pieces of paper, dust or other flammable material which has accumulated in or is attached to the engine.

##### - Electrical cabling

Short circuits can cause fires. Prevent by following the precautions below:

- Always keep the electrical connections of the machine clean and tightly sealed;
- Tighten any loose connectors or cabling clamps. Replace those that are damaged.

**2 - Observe the instructions and warnings contained in the present manual and on the safety plates on the engine.**

**Inappropriate functioning and maintenance can result in serious injury or even death.**

#### 3 - Ventilation of closed areas:

In the event that it is necessary to start the engine in a closed environment or if petrol or cleaning oil is being used, open doors and windows to ensure adequate ventilation and, therefore, avoid gas poisoning.

4 - Motor label (see  3.1)

### 2.5. Necessary equipment

All the operations can be carried out with the tools normally used in a good garage.

The , symbol used for certain interventions indicates that special tools or equipment are recommended.

### 2.6. Symbols and terms used for safety purposes

Some paragraphs in this manual are preceded by symbols which indicate the following:



**Operations that should be carried out with utmost care to avoid impairing the functionality and safety of the engine and/or lawnmower on which it is installed.**



**Operations that should be carried out with utmost care to avoid injury to operators.**

**“WARNING” stresses the risk of injury to oneself and others if instructions and regulations are not observed.**



### 3. TECHNICAL DATA AND SPECIFICATIONS

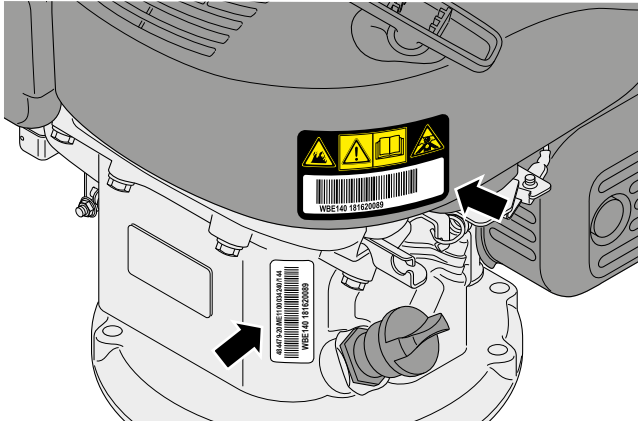

#### 3.1. Identification

Every motor is marked with a serial number on the base and applied on the canopy; this serial number characters and can identify:

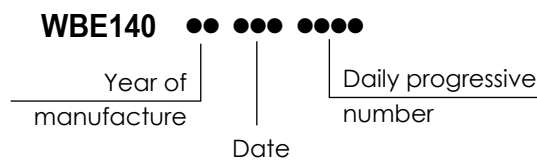

The serial number must be reported on every operating sheet in the warranty application and is fundamental for identifying and ordering spare parts.

#### 3.2. Technical data

	WBE 120	WBE 140
Displacement	123 cc	139 cc
Bore	65 mm	
Stroke	37 mm	42 mm
Compression ratio	8,1 : 1	
Speed (r.p.m.)	2900 (±100)	
Fuel tank capacity	0,75 litres	0,70 litres
Oil sump capacity	0,50 litres	
Dry weight	8,50 kg	

#### 3.3. Adjustments

Distance between spark plug electrodes	0,7 - 0,8 mm
Coil air gap	0,35 - 0,45 mm
Inlet valve clearance	0,10 - 0,15 mm
Exhaust valve clearance	0,15 - 0,20 mm

#### 3.4. Expendable materials

	WBE 120	WBE 140
Petrol	Unleaded (green) minimum 90N.O.	
Engine oil	- from 5 to 35 °C - from -15 to +35°C	
Spark plug	K7 RTC	
Starter rope	ø 3,2x2200 mm	

#### 3.5. Use limits

The following table gives the use limits of certain components subject to wear, after which the component must be replaced.

	WBE 120	WBE 140
Minimum inlet valve stem diameter	5,32 mm	
Minimum exhaust valve stem diameter	5,27 mm	
Minimum inlet valve head rim thickness	0,50 mm	
Minimum exhaust valve head rim thickness	0,50 mm	
Minimum valve spring length	33,50 mm	
Maximum gap between ends of cylinder rings	1,0 mm	
Max. axial gap for compression rings	0,15 mm	
Minimum gudgeon pin diameter	12,95 mm	
Max. gudgeon pin-piston seat diameter	13,05 mm	
Maximum connecting rod diameter	gudgeon pin side	13,07 mm
	crank side	26,07 mm
Diam. connecting rod's pin on engine shaft	25,92 mm	
Verify the engine shaft extremes	0,10 mm	
Diameter Pump seat on camshaft	13,92 mm	
Diameter aspiration cam	27,30 mm	
Diameter discharge cam	27,40 mm	

### 3. TECHNICAL DATA AND SPECIFICATIONS

#### 3.6. Tightening torques

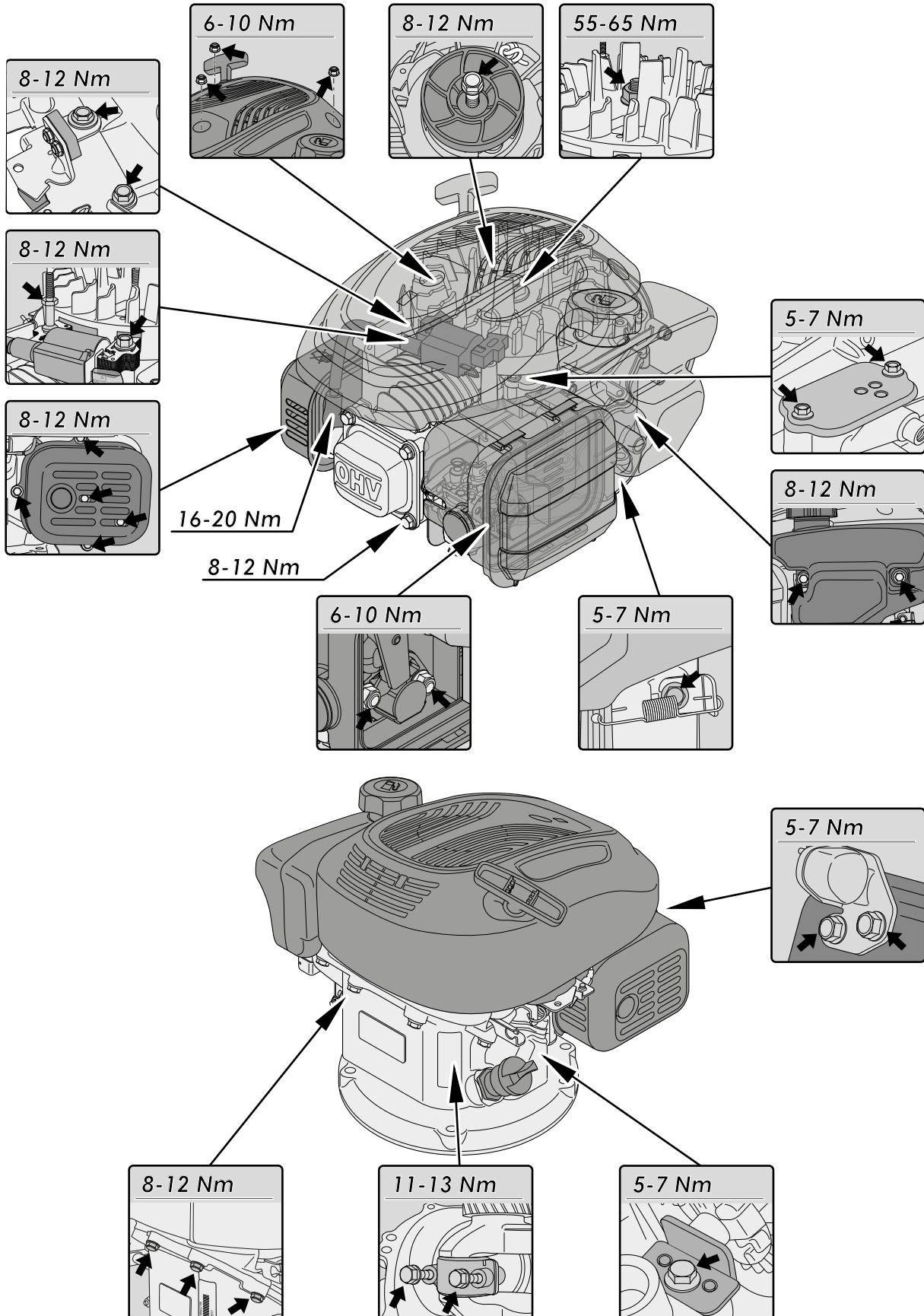

### 3. TECHNICAL DATA AND SPECIFICATIONS

#### 3.7. Table of Tightening torques

Chapter Ref.	Description of screw	Tightening torques
5	Tank fixing screw	8 - 12 Nm
5 - 6	Fixing nuts, starter assembly	6 - 10 Nm
6	Starter screw	8 - 12 Nm
8	Fixing nuts carburettor and filter	6 - 10 Nm
9	Fixing plate screws	5 - 7 Nm
10 - 13	Fixing screw AUTO-CHOKE	5 - 7 Nm
11 - 14	Spark plug tightening torque	25 - 32 Nm
11	Fixing screw reel	8 - 12 Nm
11	Coil fixing stud	8 - 12 Nm
12	Brake support screws	8 - 12 Nm
13	Muffler protection fixing screws	8 - 12 Nm
13	Muffler fixing screws	8 - 12 Nm
14	Screws valve cover	8 - 12 Nm
14	Flywheel fixing nut	55 - 65 Nm
14	Blow-by closure plate screws	5 - 7 Nm
15	Union screws under carter and sump	8 - 12 Nm
15	Counterweight governor fixing screw	5 - 7 Nm
15	Fixing screws lower connecting rod cap	11 - 13 Nm

**P.S. For the coupling torque of all standard screws refer to the single table.**

### 3. TECHNICAL DATA AND SPECIFICATIONS

#### 3.8. Identification of engine units

For ease of reference, this manual has subdivided maintenance operations into different sections, each of which refers to an engine component unit as indicated in the diagrams below.

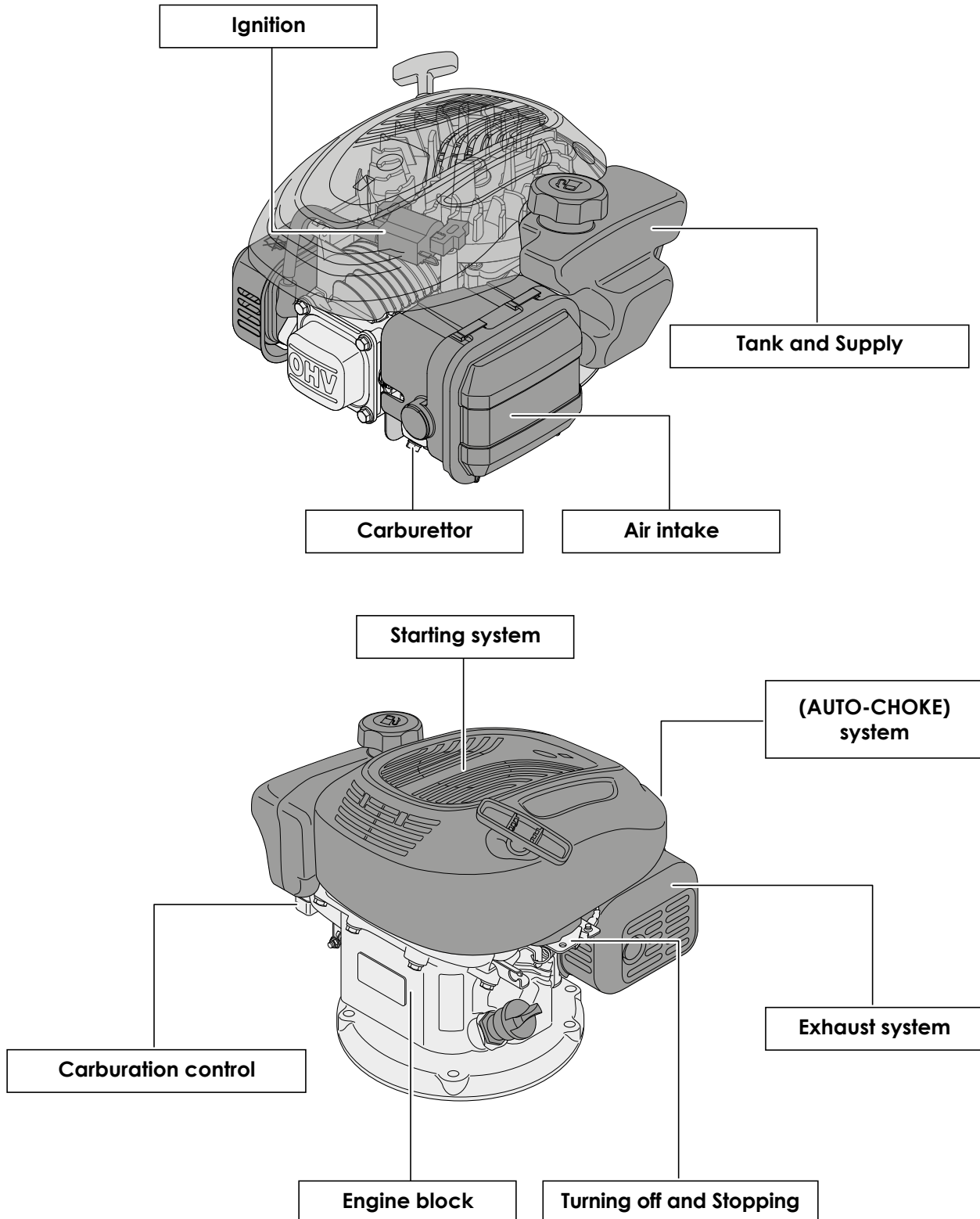

### 4. ENGINE TUNING AND TESTING

#### 4.1. Operating guidelines

The engine requires a series of interventions (shown in the table below) in order to ensure minimum basic maintenance.

Operation	First 5 hours	Every 5 hours or daily	Every 25 hours or every season	Every 50 hours or every season	Every 100 hours
Check oil level	-	■	-	-	-
Change oil <sup>*(1)</sup>	■	-	-	■	-
Clean muffler and engine	-	■	-	-	-
Check air cleaner <sup>*(2)</sup>	-	■	-	-	-
Replace air cleaner <sup>*(2)</sup>	-	-	■	-	-
Check spark plug	-	-	-	■	-
Replace spark plug	-	-	-	-	■

<sup>\*(1)</sup> Replace the oil every 25 hours if the engine is working at full load or at high temperatures.  
<sup>\*(2)</sup> Clean the air filter more often if the machine is working in dusty areas.

For the operations that are not difficult for the final user the assistance centre must maintain the motor in perfect efficiency, in accordance with two intervention lines:

- Tuning the engine whenever possible.
- Recommending the client a routine maintenance program at set intervals (e.g. at the end of the season or before a long period of inactivity).

#### 4.2. Engine tuning program

As part of general engine tuning or any intervention on the lawn tractor, it is recommended that the Service Centre performs a series of operations aimed at maintaining the engine's efficiency.

Tuning should involve:

- external blowing and cleaning the cylinder head, cylinder and muffler by removing any remains of grass and mud;
- checking the oil level, topping up or replacing parts if necessary;
- inspecting the condition of the starter rope and checking that it functions correctly [ [👉 6.2];
- cleaning the filter element [ [👉 7.1];
- emptying and cleaning the fuel tank and checking the breather pipe [ [👉 5.2];

- adjusting the speed [ [👉 9.1];
- inspecting the condition of the spark plug; checking the distance between the electrodes [ [👉 11.1];
- tightening the screws [ [👉 3.7];
- functional test [ [👉 4.3].

Should the checks and adjustments fail to achieve a satisfactory result, refer to chapter [ [👉 16] for troubleshooting.

**4. ENGINE TUNING AND TESTING****4.3. Functional test**

A functional test needs to be carried out at the end of each servicing operation, to check that the operations made are effective. The test must be performed in compliance with the safety regulations regarding the use of the lawnmower on which the engine is installed.

The functional test is carried out as follows:

**a. Refuelling and checking the supply system**

When you have refuelled the tank with new petrol, check the seal of the tank, the cap and the carburettor pipe.

**b. Hot and cold starting test**

The engine is equipped with intelligent starter system (AUTO-CHOKE), perform some cold and hot starts to make sure they happen regularly

**c. Check the engine rpm**

When the engine is hot enough, check the engine speed; the reading should be equal to the specifications [ 3.2].

If all of these operations have a positive result, the engine can be considered fully serviceable and be returned to the client.

**5. TANK AND SUPPLY**

**IMPORTANT:** Carefully read the information below before commencing any intervention.

**General Information**

The **fuel supply system** comprises the petrol tank connected to the carburettor by a pipe; a mesh filter at the bottom of the tank prevents deposits and impurities from reaching the carburettor.

The tank is equipped with a filter, located at the bottom of the tank, which prevents deposits and impurities from reaching the carburettor.

The supply to the carburettor float chamber is caused by gravity and the volume of petrol taken from the tank as the engine runs is compensated by a breather pipe in the cap.

See the relevant section [ 16] for advice on resolving problems due to the malfunctioning of the petrol supply system.



**WARNING:** All interventions on the supply system must be performed in safe conditions, therefore:

- do not smoke;
- always empty the tank;
- work in a ventilated environment away from naked flames or unprotected sources of heat;
- collect any remaining petrol by positioning a suitable container under the engine, avoiding soiling the work bench;
- remove all traces of spilt petrol immediately;
- check you have connected the pipes before pouring petrol back into the tank.

### 5. TANK AND SUPPLY

#### 5.1. Emptying and removing the tank

1 - Remove the ring (1) of the petrol pipe (2) from the tank side and drain all the fuel from the tank and the pipe into a suitable container.

2 - Remove the starter assembly (3) by loosening the three nuts (4).

3 - Loosen the two rear screws (5) and remove the tank (6).

4 - When fitting, perform the above operations in reverse.



**WARNING:** Before refilling the tank with new fuel, check that the petrol pipe is intact.

#### 5.2. Cleaning the tank

1 - Remove the tank  5.1.

2 - Slide out the filter tube (7) and blow compressed air through it so as to remove any deposits inside.

3 - Keeping the hole (8) in the spigot closed, pour about 100 cc of clean petrol into the tank and shake it vigorously to clean the inside.

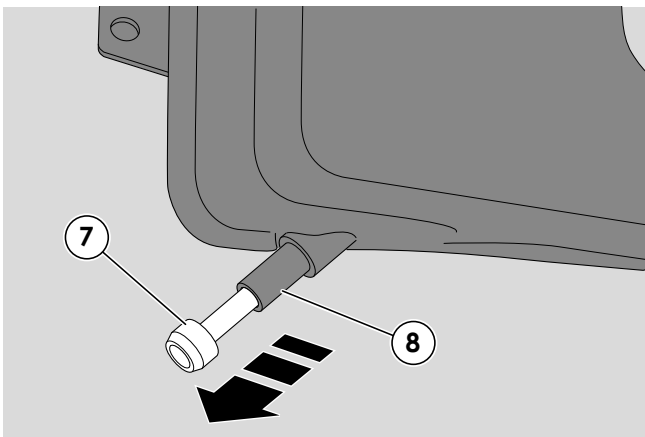
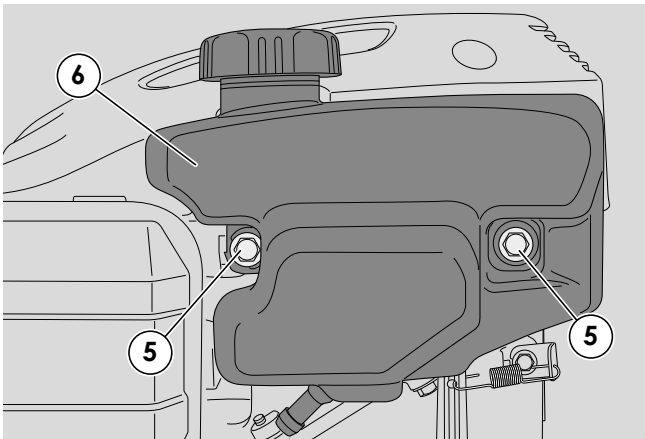
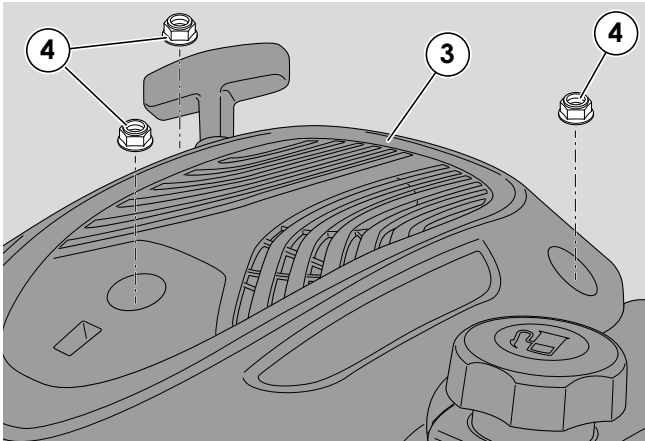
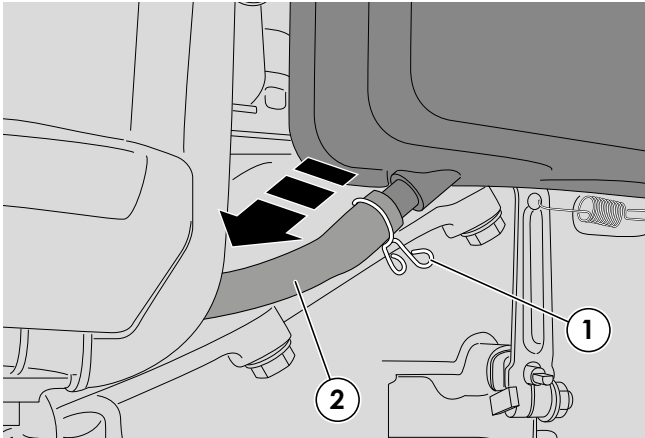



### 5. TANK AND SUPPLY

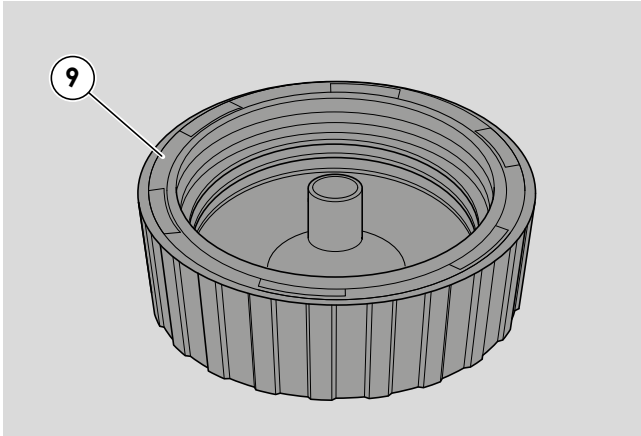

4 - Empty the tank and dispose of the petrol used for cleaning in accordance with the laws in force.

5 - Refit the tank [  5.1 ] tightening the screws (5) to the torques indicated.

6 - Replace the starter assembly by securing the nuts (4) at the specified torque.



**WARNING:** Before refilling the tank with new fuel, check that the petrol pipe is intact.

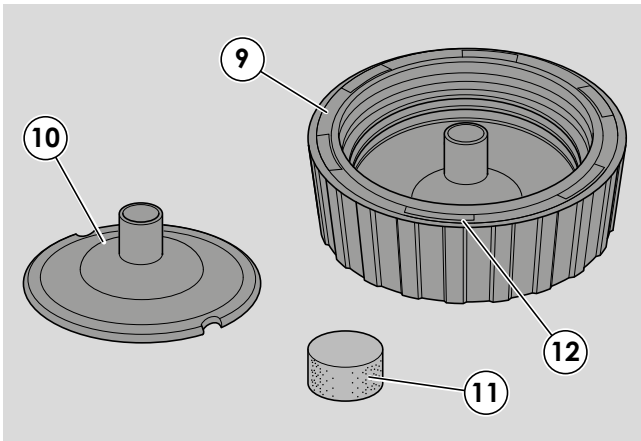

#### 5.3. Checking and cleaning the breather pipe

1 - Remove the cap (9) and pull out the gasket (10) and the sponge (11).

2 - Check that:

- the gasket (10) is intact and without cracks or fissures;

- the air passages (12) inside the cap are not clogged;

- the sponge (11) is not crushed or broken.



**NOTE:** Always replace the entire cap if the gasket or sponge is damaged.

#### Tightening torques

4	Fixing nuts, starter assembly	6-10 Nm
5	Tank fixing screw	8-12 Nm

### 6. STARTING SYSTEM

#### General information

The **starter assembly** inside the cover consists of a rope wound around a pulley. The movement from the pulley to the flywheel (and therefore to the engine shaft) is transmitted through a pair of couplings. The return of the pulley and the rewinding of the rope are obtained from a spiral spring.

See the relevant section [\[🔧 16\]](#) for advice on resolving problems due to the malfunctioning of the starting system.

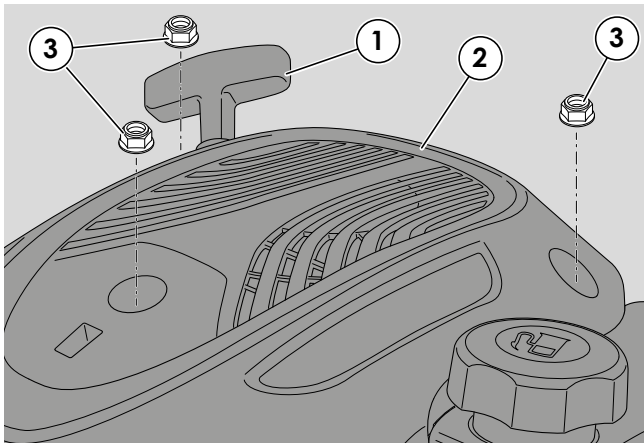

#### 6.1. Removing the starter assembly

1 - To get access to the starter assembly (1), the cover (2) must be removed by unscrewing the three nuts (3).

2 - Refit the starter assembly (1) by tightening the cover nuts (3) to the torque indicated.

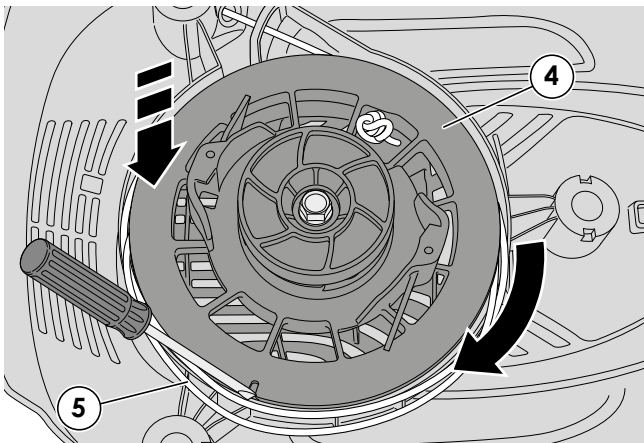

#### 6.2. Replacing the rope

1 - Remove the starter assembly [\[🔧 6.1\]](#).

2- Keep hold of the pulley (4) and, with the help of a screwdriver, slowly unwind (clockwise) the entire rope (5) from the pulley. Then carefully release the pulley in order to gradually unload the return spring. If the rope breaks, the spring will be already released and you will only have to unwind the rope.

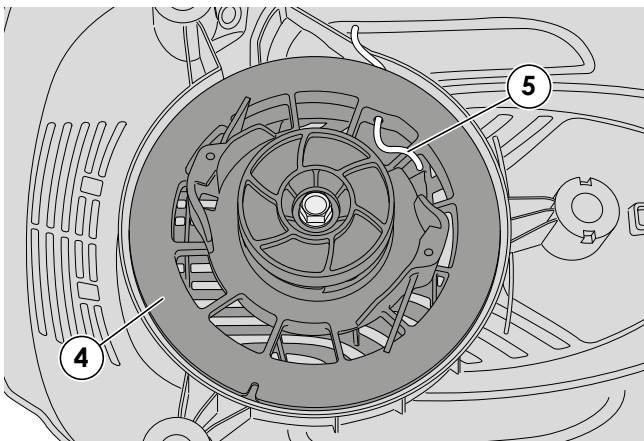

3 - Undo or cut the knot at the end of the rope (5) and remove the section still attached to the pulley.

### 6. STARTING SYSTEM

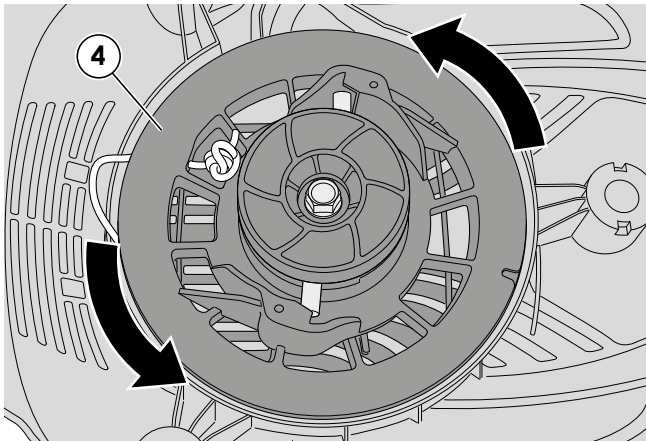

4 - Rotate the pulley (4) through about 7 complete turns anticlockwise in order to load the spring and hold it still.

5 - Insert one end of the rope (5) (ø 3,2mm - length 2200mm) through the guide in the ventilation grille, into the hole in the pulley (4), and fasten it by tying a knot.

6 - Insert the other end of the rope into the grip (6), fasten it with a knot and carefully release the pulley to allow the rope to rewind itself completely onto the pulley.

7 - Check that the pulley rotates freely.

8 - After pulling the entire length of the rope, check that the pulley (4) is able to complete another 2-3 turns before compressing the spring.

9 - Refit the starter assembly [👉 6.1].

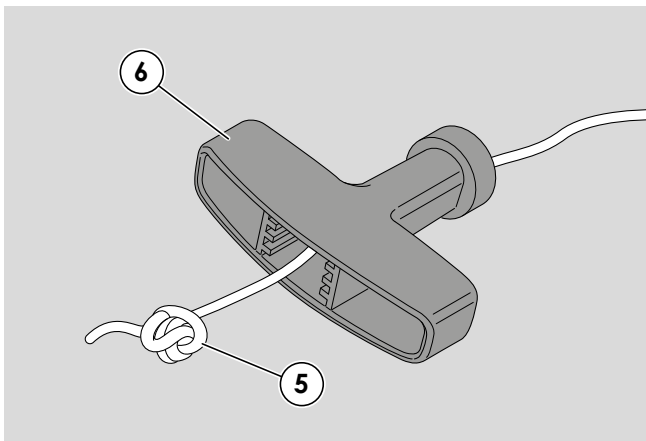

#### 6.3. Replacing the hooks

1 - Remove the starter assembly [👉 6.1].

2 - Undo the screw (7) and remove the cover (8) setting aside the spring. Take care that the pulley (4) does not slide out of its housing.

3 - Move the return springs (9) gently out of the way, rotate the hooks (10) clockwise and remove them.

**NOTE: Always replace the complete set consisting of hooks, return springs, cover and screw, as a unit.**

4 - When fitting, tighten the screw (7) to the torque indicated.

5 - Refit the starter assembly [👉 6.1].

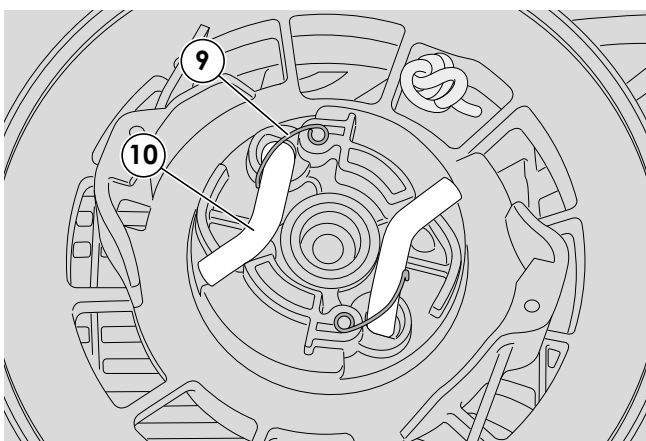
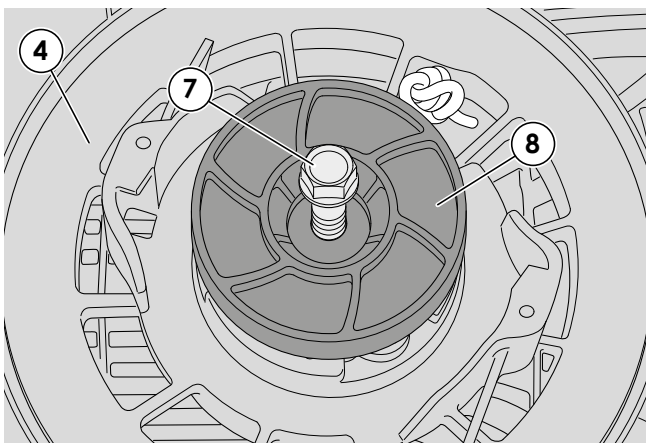

#### Tightening torques

3	Fixing nuts, starter assembly	6-10 Nm
7	Starter screw	8-12 Nm

#### Technical information

Starter rope dimensions	ø 3,2x2200 mm
-------------------------	---------------

### 7. INTAKE SYSTEM

#### General information

The **intake system** uses an air filter directly connected to the carburettor by means of a manifold which conveys the air/petrol mixture to the inlet valve.

See the relevant section [👉 16] for advice on resolving problems due to the malfunctioning of the air intake system.

**An inefficient filter can let dust or debris enter the cylinder, causing premature wear to the piston rings and cylinder.**

The air filter is found on the left hand side of the engine and can be inspected without having to remove other parts.

The filter assembly is to be removed only to accede the carburettor.

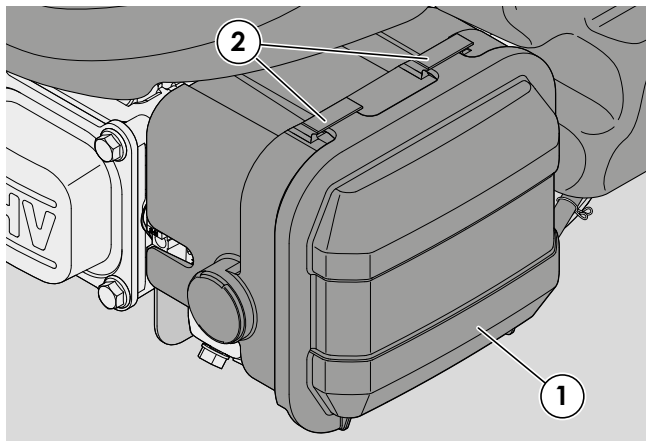

#### 7.1. Servicing and replacing the sponge filter element



**WARNING: Never run the engine without air filter. The engine would certainly be damaged.**

1 - Clean the area around the filter cover (1) by blowing it with compressed air.

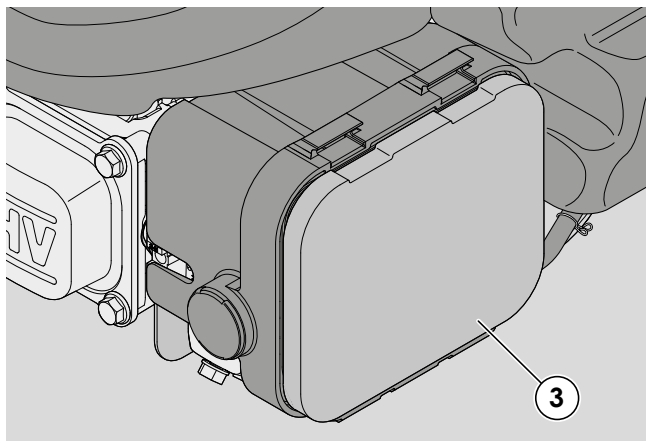

2- Remove the cover (1) by pressing on the upper tab (2).

3 - Remove the filter element (3).



**WARNING: Close the intake duct to prevent the entry of foreign objects (see figure).**

4 - Remove the filter element (4).

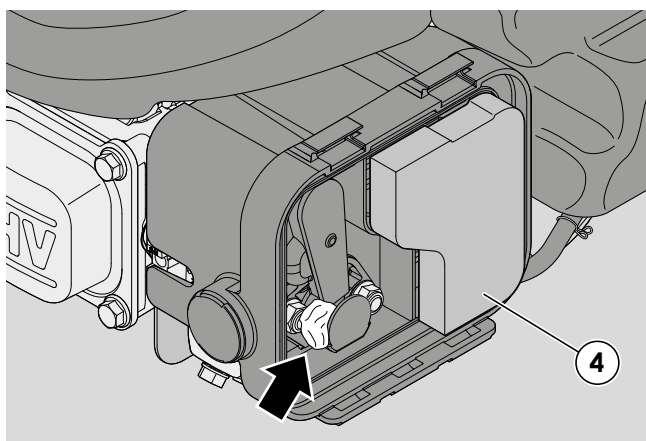

5 - Check carefully that the filters are not damaged. If they are, replace them.

### 7. INTAKE SYSTEM

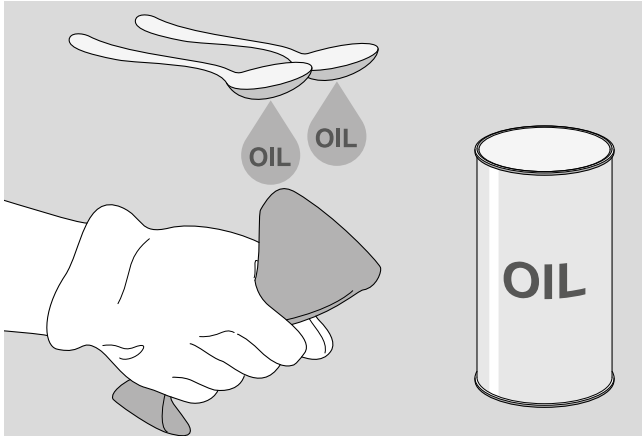

**!** **WARNING:** The filter elements must be kept well cleaned and soaked in oil. Replace them if broken, cut or with crumbled parts. Do not use compressed air to clean the filters.

6 - Wash the sponge filter elements in water and detergent and dry them with a clean cloth.

7 - Soak the filters with two spoonfuls of clean motor oil and squeeze them several times to evenly distribute the oil.

8 - Remove any excess oil with a clean cloth.

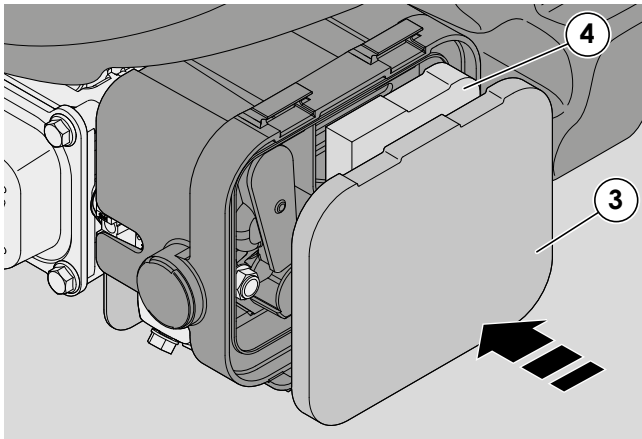

9 - Reassemble the filter elements (4) and (3) in their seats.

**!** **WARNING:** When assembling the filter element (3), make sure it is properly positioned between the tabs, as shown in the figure.

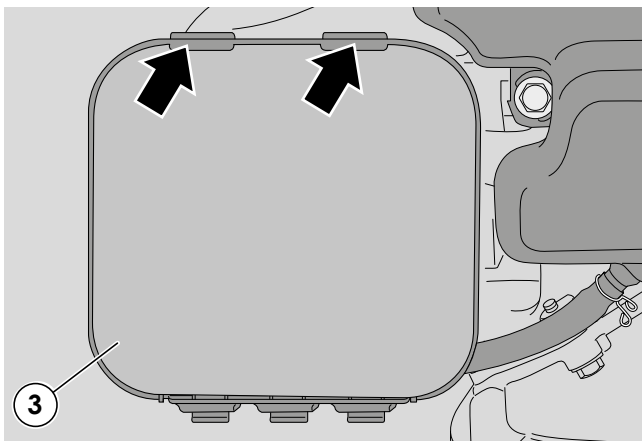

11 - Reassemble the cover (1), being sure to correctly hook the tabs (2).

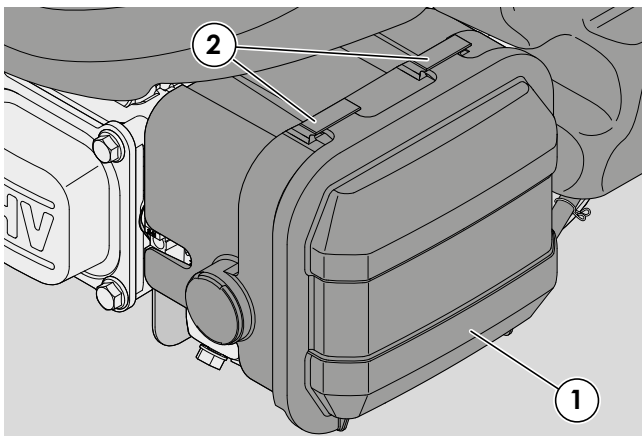

### 8. CARBURATION

#### General information

The **carburettor** has a float with a fixed jet and a "AUTO-CHOKE" control.

See the relevant section [\[🔧 16\]](#) for advice on resolving problems due to carburation.

The carburettor is located on the left hand side of the engine. For maintenance operations, it is necessary to remove the air intake filter in the sequence shown below.

Some of the following operations can be facilitated by removing the engine from the machine.

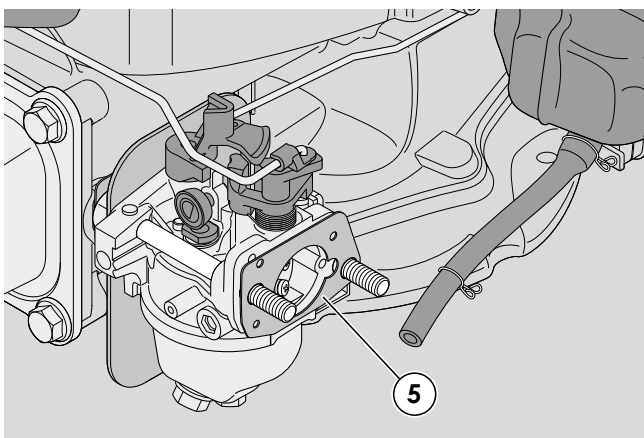
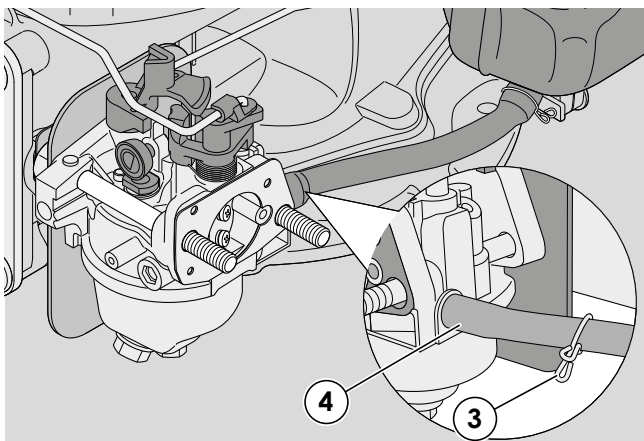
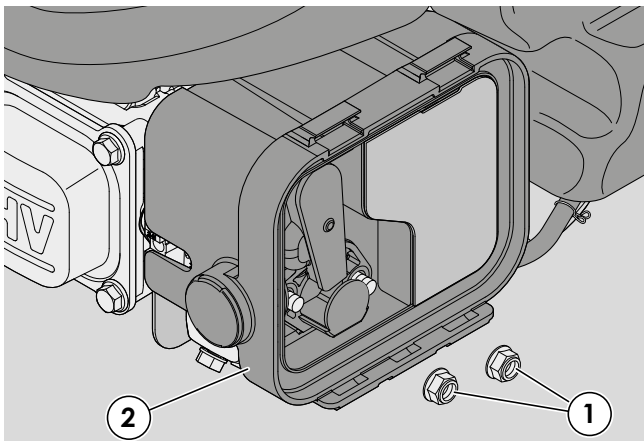

**⚠ WARNING!** All operations on the tank and supply system must be carried out in safe conditions, so:

- do not smoke;
- always empty the tank if petrol is not strictly necessary for the operation to be carried out;
- work in a ventilated environment away from naked flames or unprotected sources of heat;
- collect petrol in a suitable container with a cap using a funnel and avoid spilling it on the work bench;
- remove all traces of spilt petrol immediately;
- check you have connected the pipes before pouring petrol back into the tank.

#### 8.1. Removing and cleaning the carburettor

1 - Remove the filter unit [\[🔧 7.1\]](#).

2 - Unscrew the two nuts (1) holding the filter carrier (2).

3 - Extract the filter holder (2) by disconnecting the breather tube. Be careful of the petrol pipe.

4 - Remove the hose clamp (3) and the petrol pipe (4). Drain the contents of the pipe into an appropriate container.

5 - Remove the gasket (5).



### 8. CARBURATION

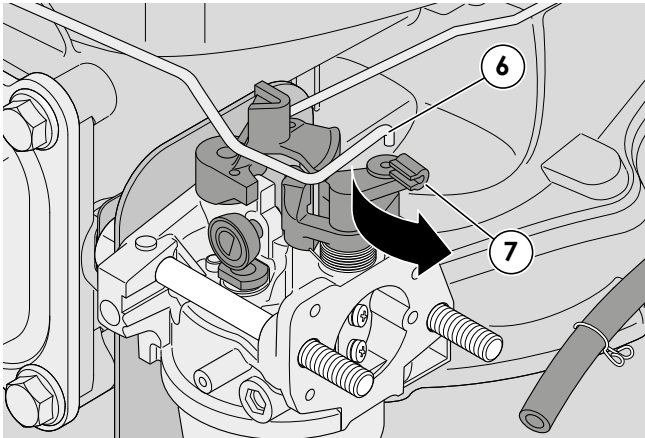

6 - Remove the tie rod (6) of the AUTO-CHOKE lever by releasing the locking clip (7). Slightly pull out the carburettor to facilitate the release of the intake butterfly shaft.

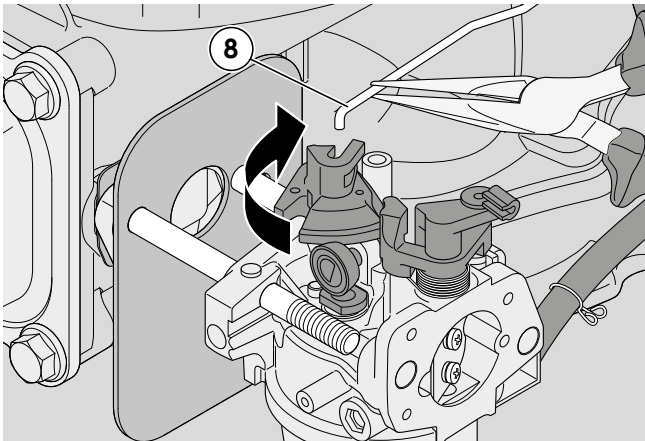

7 - Rotate the butterfly valve clockwise 90° and, using pliers, disconnect the intake butterfly rod (8).

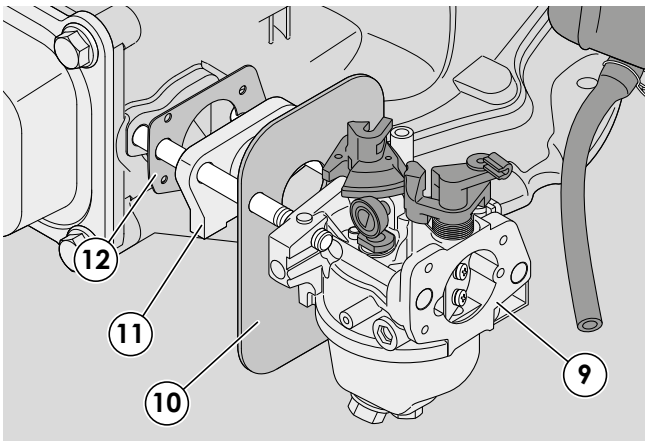

8 - Completely remove the carburettor (9) the gasket (10), the spacer (11) and the heat protection gasket (12).

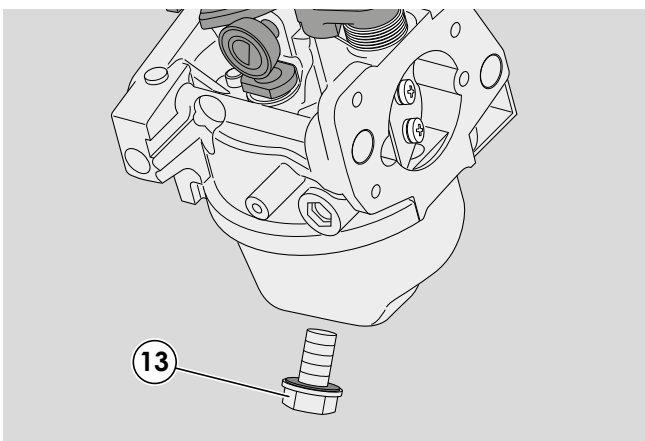

**NOTE:** Empty any remaining petrol from the tank by removing the drain screw (13) as shown in the figure. When finished, replace the screw.

### 8. CARBURATION

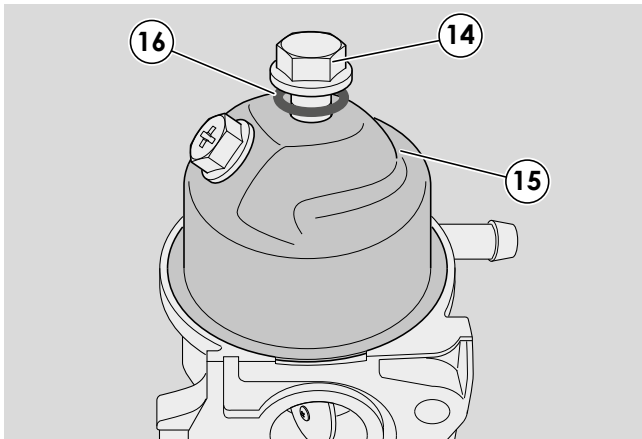

9 - Unscrew the central screw (14) securing the tank (15) and remove the corresponding OR (16).

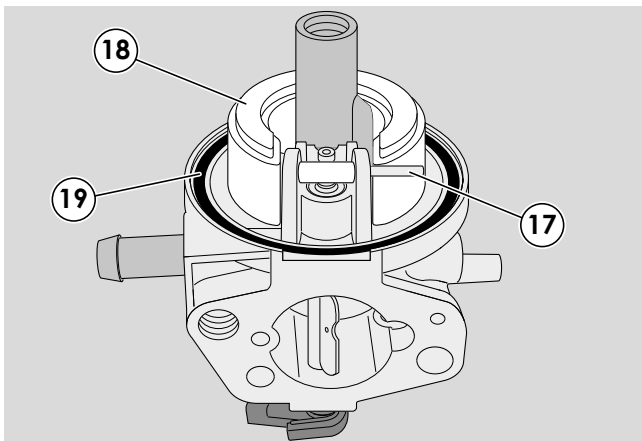

10 - Pull out the pin (17), dismount the float (18) and remove the gasket (19).

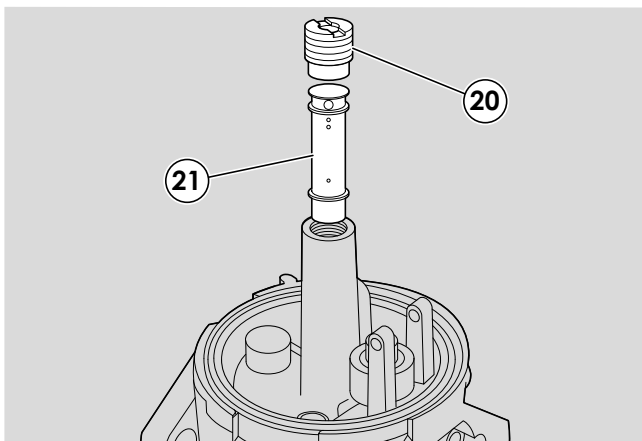

11 - Undo the main jet (20) and pull out the pilot jet (21).

12 - Check that no impurities or dirt are deposited in the seat of the needle (22) and of the pilot jet. **Make sure the rubber tip of the needle and the float are not marked or worn. If they are, replace them.**

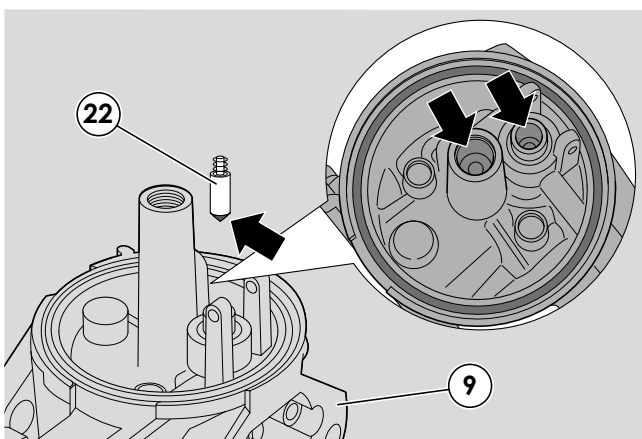



13 - Clean the carburettor (9) the main jet (20) and the pilot jet (21) thoroughly by immersing them in clean petrol (or a detergent) for 24 hours. Dry with compressed air, blowing well through the carburettor holes.

14 - Mount the carburettor following the previous points 10, 9 and 8 in reverse order, remembering that:

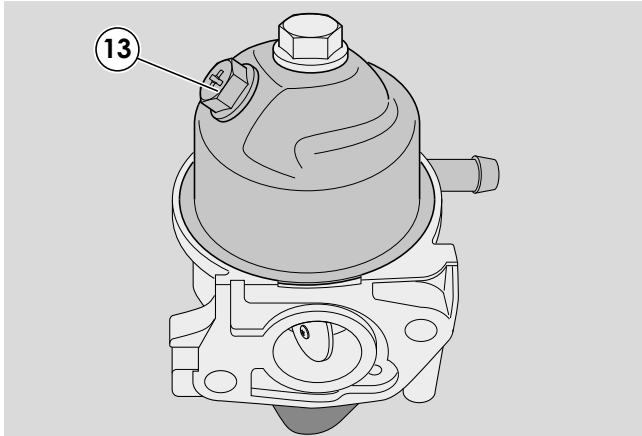

### 8. CARBURATION



 It is always advisable to replace the washer (19) and the O-Ring (16) of the float chamber;

- **the float (18) must oscillate freely on the pin (17);**

- the jet (20) should never be modified or replaced with others even if they seem to have the same specifications;

- the screw (13) to drain the tank should be facing the front of the engine.

15 - Reassemble the tie rod (8), checking that the governor system moves smoothly without stopping.

16 -  Always replace washers (5), (10) and (12) when re-mounting the carburettor onto the engine.

17 - Assemble the filter holder and tighten the relative nuts (1) with the torque indicated. Refit the filter unit [ 7.1].

#### 8.2. Replacing the carburettor

1 - Perform operations 1 - 2 - 3 - 4 - 5 - 6 - 7 - 8 - 14 - 15 - 16 - 17 indicated in section [ 8.1] above.

#### 8.3. Adjusting speed



**NOTE: This operation is carried out by adjusting the governor system [ 9.1].**

#### 8.4. Adjusting the carburation



**NOTE: The carburation is set in the factory and does not normally need changing. In the event of irregular functioning, clean the carburettor as indicated in section [ 8.1].**

#### Tightening torques

1	Carburettor nuts/filter	6-10 Nm
---	-------------------------	---------

### 9. GOVERNOR SYSTEM OF THE CARBURETTOR

#### General information

The **carburettor governor system** uses a engine shaft linkage fitted on a support fixed to the left-hand side of the engine, completed by a counterweight device, driven by the camshaft, and thus sensitive to changes in the engine's revolution pattern depending on load.

The force of the counterweights, transferred to the control lever, tends to shut the main carburettor butterfly, in opposition with the spring that would keep it open; the balance between the spring loading and the thrust of the counterweights on the control lever modifies the butterfly opening and adapts the flow of fuel to the engine so that the revolution speed is kept constant with engine load changes.

See the relevant section [ 16] for advice on resolving problems related to the governor system.

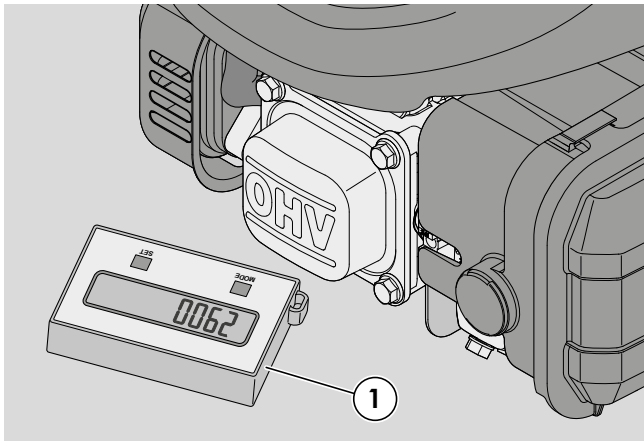

#### 9.1. Adjusting speed

1 -  Check the rotation speed on the speed indicator (1).

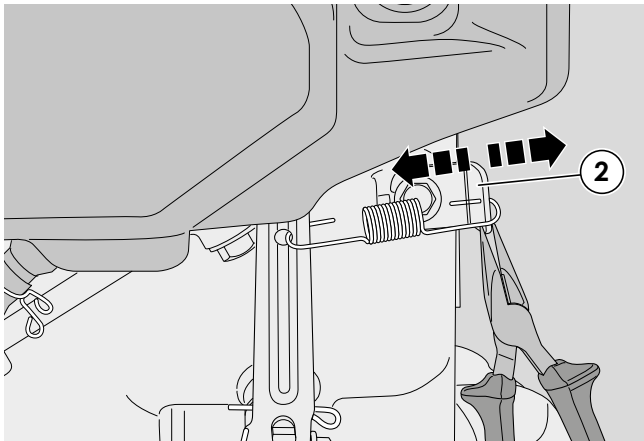

2 - Using pliers, bend the plate (2) slightly to the right to increase the number of revs and to the left to reduce them.

 **NOTE:** The engine speed must be between 2900 ( $\pm 100$ ) r.p.m.; if this value is not found, proceed as indicated.

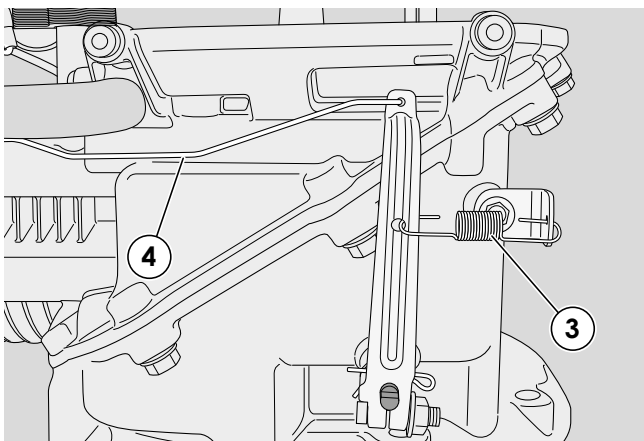

3 - Check:

- to facilitate the inspection, remove the tank and filter unit;

- that the spring (3) is intact and that it is properly positioned in its seat;

- that the tie rod (4) is intact and not deformed;

### 9. GOVERNOR SYSTEM OF THE CARBURETTOR

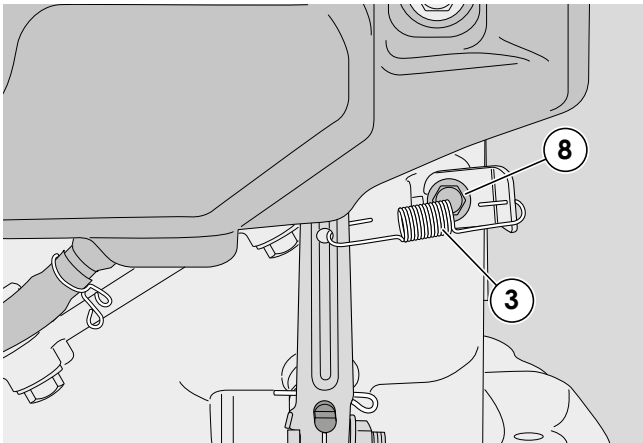
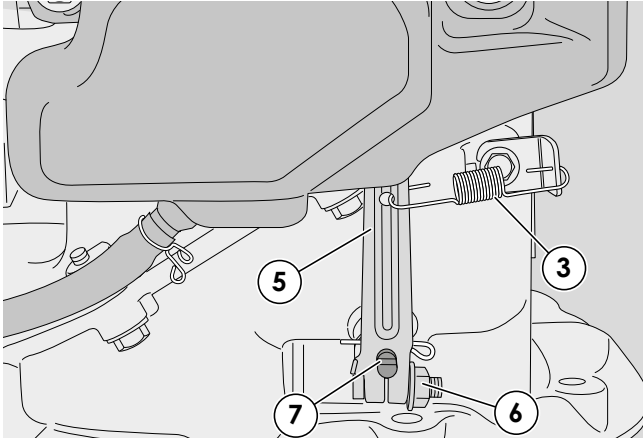

4 - If the above checks do not show any faults, the phasing of the governor's control lever (5) with respect to the counterweight device must be checked:

- stop the engine and make sure that the lever (5) is in the end run position;
- slacken off the control lever (6) locknut (5);
- without changing the position of the lever (5), rotate the pin (7) clockwise with pliers up to the limit switch, then lock the nut (6).



**NOTE:** If the plate (2) is damaged, replace it by disconnecting the spring (3) and removing the screw (8).

5 - Adjust the speed [ 9.1].

#### Tightening torques

8 Fixing plate screws 5-7 Nm

#### Technical information

Speed 2900 (±100) g/1'

#### Special equipment

1 Speed indicator

### 10. AUTO-CHOKE SYSTEM

#### General information

The smart starter system (AUTO-CHOKE System) is a mechanism sensitive to temperature variation that adjusts the starter's throttle valve, ensuring immediate and proper starting and operating of the engine automatically.

The **AUTO-CHOKE system** assembled on the exhaust unit employs a lever connected to the adjusting pin of the second throttle valve.

See the relevant section [ 16] for advice on resolving problems related to the AUTO-CHOKE system.

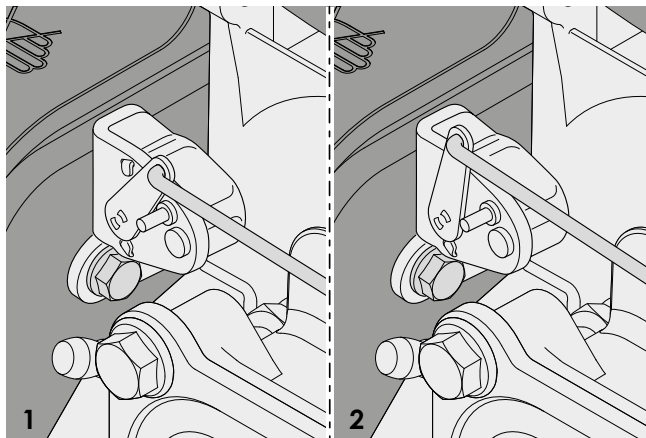
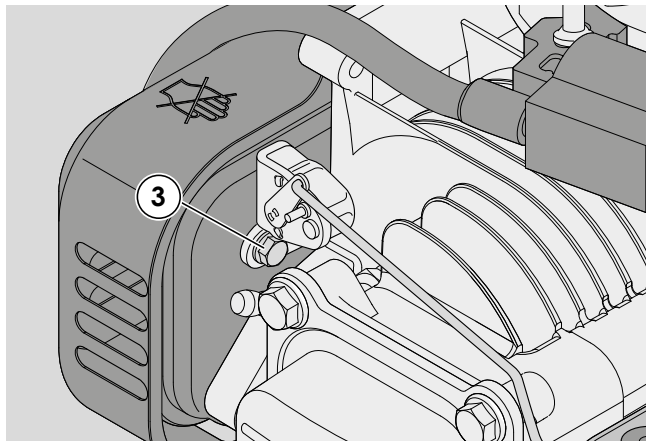
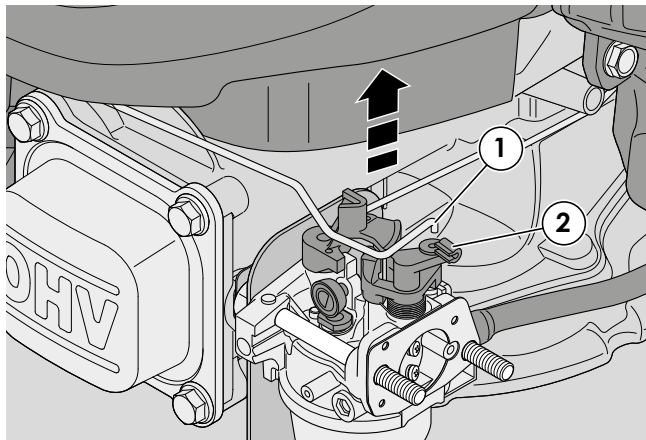

#### 10.1. Replacing of the AUTO-CHOKE system

1 - Remove the starter assembly [ 6.1] and remove the conveyor.

2 - Remove the spark plug to facilitate the operations.

3 - Remove the filter unit [ 7.1] and the tie rod (1) of the AUTO-CHOKE lever by releasing the locking clip (2).

4 - Loosen the two screws (3) and replace the AUTO-CHOKE system.

5 - Perform the above operations in reverse order when assembling.



#### NOTE:

1 - Cold engine: Closed throttle valve.

2 - Hot engine: Open throttle valve.

#### Tightening torques

3	Fixing screw AUTO-CHOKE	5-7 Nm
---	-------------------------	--------

### 11. IGNITION

#### General information

The **ignition system** has a flywheel with an electronic coil which supplies high voltage to the spark plug.

See the relevant section [ 16] for advice on resolving problems related to the ignition.

The coil and complete flywheel are accessible by removing the cowl.

Some of the following operations can be facilitated by removing the engine from the machine.

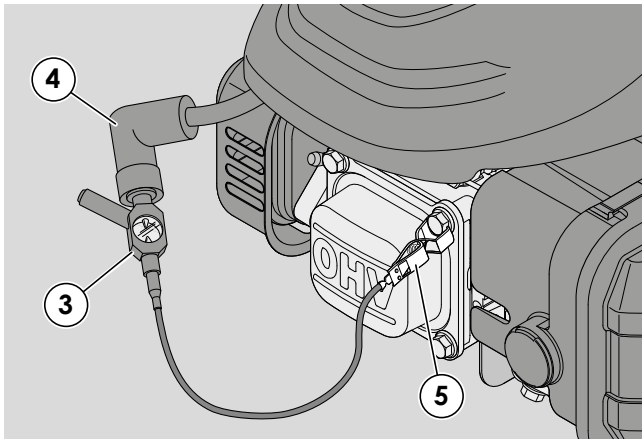
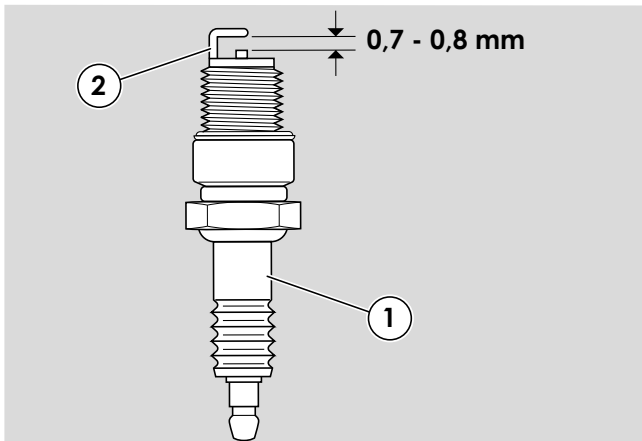

#### 11.1. Checking the efficiency of the ignition system

1 - Dismount the spark plug (1) and look at the colour on the end of the thread. This can give you a good idea of the carburation:

- **black**: mixture too greasy due to clogged air filter;
- **nut brown**: regular carburation.

**Replace the spark plug** (with one of the same or equivalent characteristics) **if the electrodes (2) are burnt or if the porcelain is broken or cracked.**



#### **FIRE HAZARD:**

- **do not check the ignition system if the spark plug is not screwed in place;**



- **always use the specific tool for the spark test.**



2 - Connect the tester (3) to the spark plug cap (4) and to earth on the engine (5). Activate the starter and see in the instrument if the spark jumps.

3 - If the test has a positive result, clean the electrodes (2) with compressed air and adjust the distance to 0.7-0.8 mm. Remount the spark plug and tighten it to the specified levels.

Unless otherwise required, proceed to verify system components as indicated in section [ 11.2].

### 11. IGNITION

#### 11.2. Adjusting the air gap and checking the coil

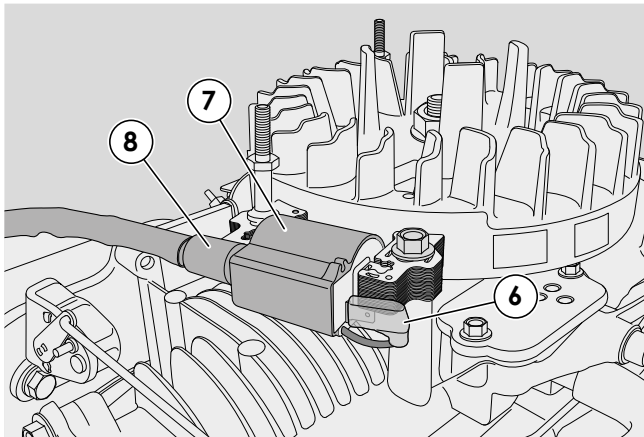

1 - Remove the starter assembly [  6.1 ] and remove the conveyor.

2 - Make sure that the earth cable faston (6) of the coil (7) is not oxidized; if it is, disconnect, clean and remount it, spraying it with a special antioxidant.

3 - Check that the coil earth cable is intact. The black spark plug cable (8) should not have any cracks or signs of deterioration or burns which reduce its efficiency and insulation level.

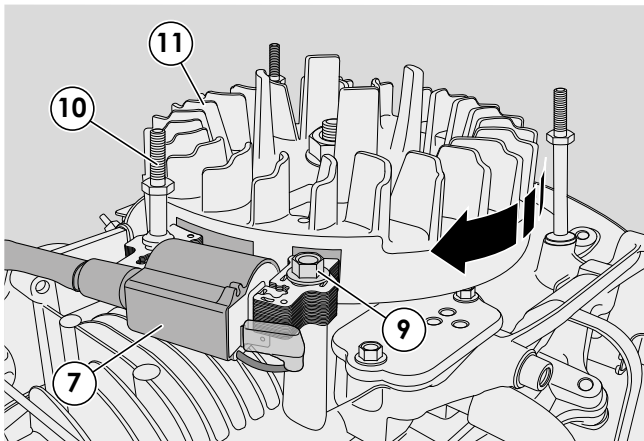

4 - Slack off the screw (9) and the stud (10) which secure the coil (7).

At the bottom of the machine to which the engine is fitted, release the safety brake.

Rotate the flywheel (11) so as to bring the magnetic inserts next to the poles of the core of the coil.

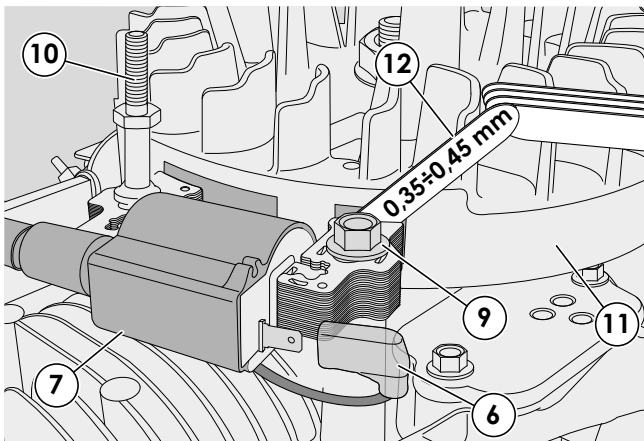

5 - Insert a 0,35 mm thickness gauge (12) between the complete flywheel (11) and the coil poles (7), push the coil until the poles come in contact with the thickness gauge and secure screw (9) and stud (10); with the flywheel locked, the airgap must be between 0,35 and 0,45 mm.



**NOTE:** An accurate inspection of the efficiency of a coil can only be carried out in a laboratory equipped with a oscilloscope.

To make a brief check, proceed as follows:

6 - Disconnect the earth cable faston (6) of the coil (7).

### 11. IGNITION

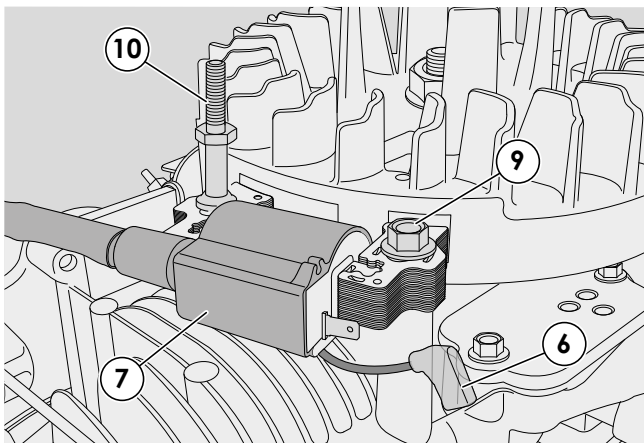
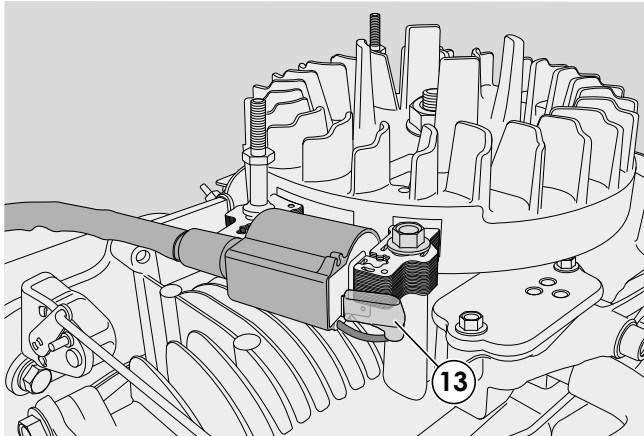

7 - Perform a spark test as indicated in [\[ \[🔧\] 11.1 \]](#).

- **If the spark jumps:** the coil functions properly and in the event of malfunction, verify that the cut-off cable (13) is not earthed.

- **if the spark does not jump:** the coil is faulty and must be replaced [\[ \[🔧\] 11.3 \]](#).

8 - Re-assemble the conveyor and the starter unit [\[ \[🔧\] 6.1 \]](#).

#### 11.3. Replacing the coil

1 - Remove the starter assembly [\[ \[🔧\] 6.1 \]](#) and remove the conveyor.

2 - Disconnect the faston of the earth cable (6).

3 - Undo the screw (9) and the stud (10) and remove the coil (7).

4 - Mount the new coil and regulate the air gap according to the procedure indicated in points 4 and 5 in section [\[ \[🔧\] 11.2 \]](#).

5 - Connect the faston of the earth cable (6).

6 - Re-assemble the conveyor and the starter unit [\[ \[🔧\] 6.1 \]](#).

#### Tightening torques

1	Spark plug tightening torque	25-32 Nm
9	Coil fixing screw	8-12 Nm
10	Coil fixing stud	8-12 Nm

#### Technical information

Type of spark plug	K7 RTC
Distance between electrodes	0,7-0,8 mm
Air gap/flywheel	0,35-0,45 mm

#### Special equipment

3	Tester for spark test
---	-----------------------



### 12. TURNING OFF AND STOPPING THE ENGINE

#### General information

The **engine is turned off and stopped** by releasing a lever on the lawnmower. The cable acts on a lever which simultaneously activates a microswitch that sends the coil to earth as well as a brake which acts on the flywheel.

The brake must be able to stop the engine within 3 seconds after it is turned off.

To solve problems in the system for turning off and stopping the engine, see the relevant chapter [\[ \[🔧\] 16\]](#).

To get access to the system for turning off and stopping the engine, remove the starter assembly.

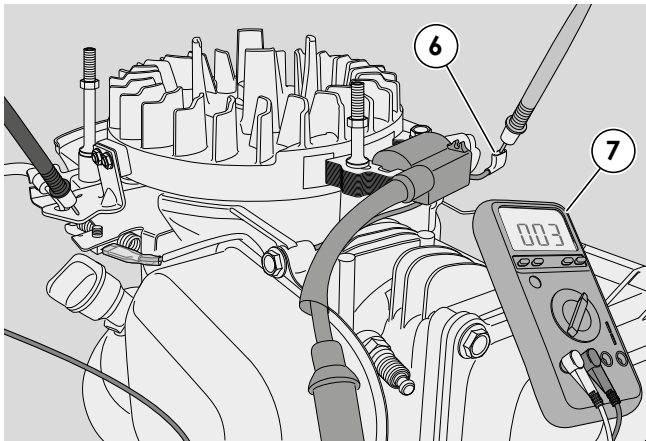
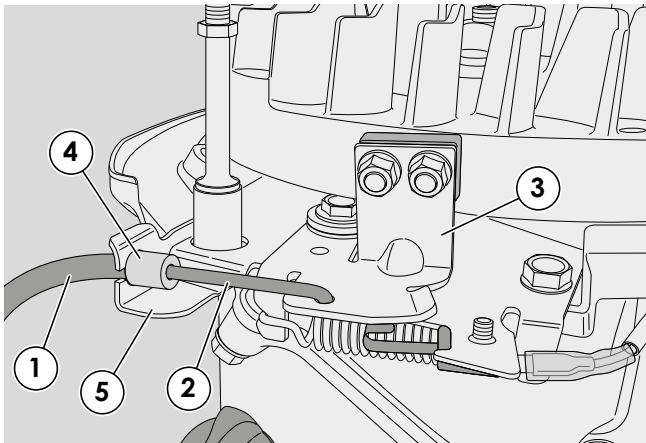

#### 12.1. Checking the control cable

1 - Remove the starter assembly [\[ \[🔧\] 6.1\]](#) and remove the conveyor.

2 - Check that the sheath (1) is not bent, that the wire (2) is securely connected to both the lawnmower lever and the lever (3) on the engine and that the terminal (4) is correctly fastened to the support (5).

3 - Check that the wire (2) runs freely inside the sheath (1) when you move the lever.

4 - Check that the end of the wire (2) is slightly loose when you release the lawnmower lever.

5 - Re-assemble the conveyor and the starter unit [\[ \[🔧\] 6.1\]](#).

#### 12.2. Checking the system for turning off the engine

1 - Disconnect the coil Faston connector (6).

2 -  Using a multimeter (7) as an ohmmeter, make contact with the leads on the points indicated in the figure.

The instrument should read:

- $\infty$  = microswitch pressed (lever pulled);
- 0 = microswitch free (lever released);

Otherwise, replace the system for turning off and stopping the engine [\[ \[🔧\] 12.4\]](#).



### 12. TURNING OFF AND STOPPING THE ENGINE

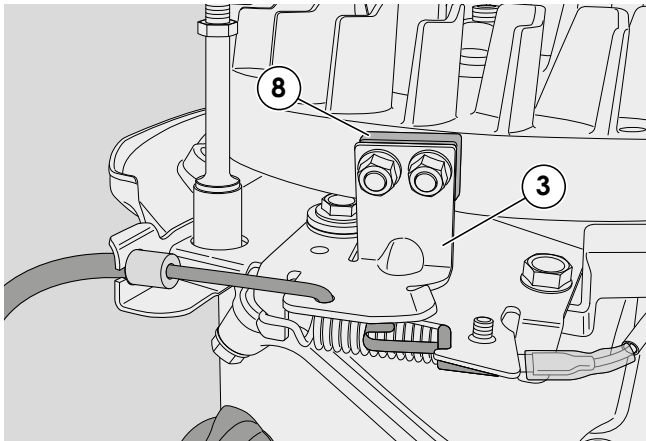

#### 12.3. Checking the brake

1 - Remove the starter assembly [ [🔧] 6.1] and remove the conveyor.

2 - Check that the thickness of the friction pad (8) is not less than 2 mm at its thinnest point.

3 - Make sure that the control lever (3) moves freely and remove any remains of grass and mud.

4 - Re-assemble the conveyor and the starter unit [ [🔧] 6.1].

5 - Start the motor and bring it to operating temperature; release the lawnmower lever and check that the engine stops within 3 seconds.

6 - If it stops after 3 seconds, replace the entire assembly [ [🔧] 12.4], because the spring or the friction pad (8) are not capable of ensuring compliance with braking times.



**WARNING! Never return the lawnmower to your client without checking brake efficiency.**

### 12. TURNING OFF AND STOPPING THE ENGINE

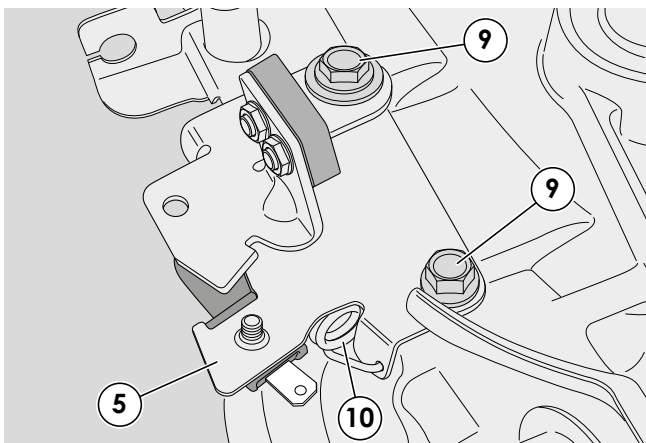
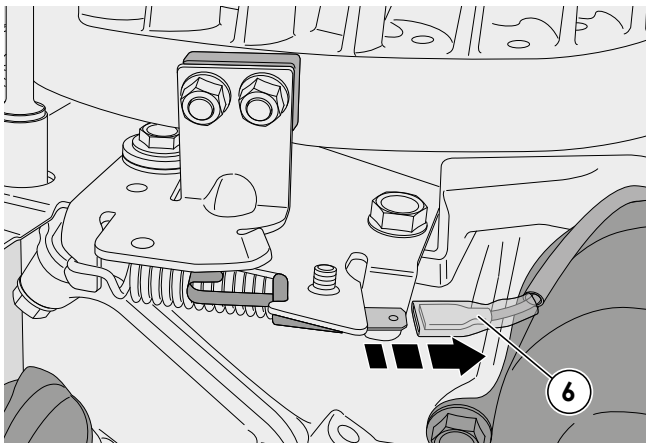
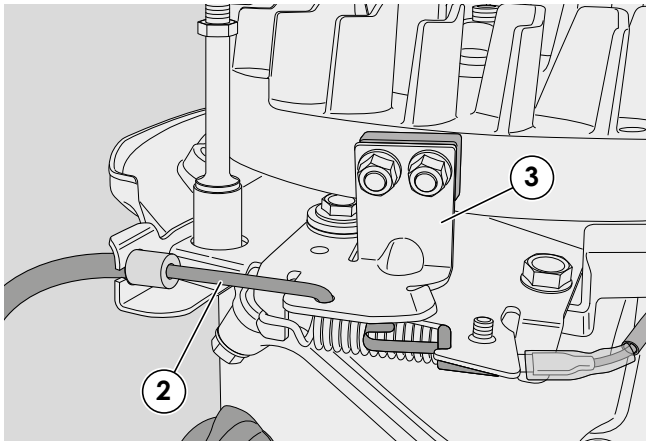

#### 12.4. Replacing the system for turning off and stopping the engine

1 - Remove the starter assembly [ [🔧 6.1] ] and remove the conveyor.

2 - Disconnect the brake wire (2) from the lever (3).

3 - Disconnect the earth cable Faston connector (6).

4 - Remove the flywheel [ [🔧 14.3] ].

5 - Loosen the two screws (9) and remove the spring (10). Remove the support bracket (5).

6 - When fitting, perform the above operations in reverse, tightening the screws (9) to the torque indicated.

7 - Re-assemble the conveyor and the starter unit [ [🔧 6.1] ].

8 - Start the motor and bring it to operating temperature; release the lawnmower lever and check that the engine stops within 3 seconds.

#### Tightening torques

9	Brake support screws	8-12 Nm
---	----------------------	---------

#### Special equipment

7	Universal tester
---	------------------

### 13. EXHAUST SYSTEM

#### General information

The **exhaust system** consists of a muffler installed on the cylinder with a guard and an inserted gasket.

To solve problems in the exhaust system, see the relevant chapter [\[16\]](#).

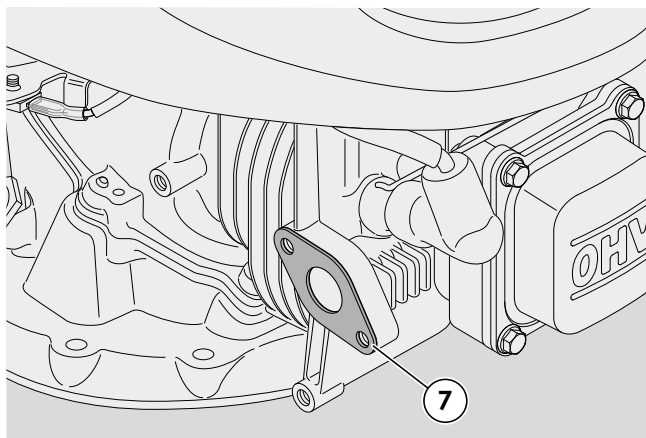
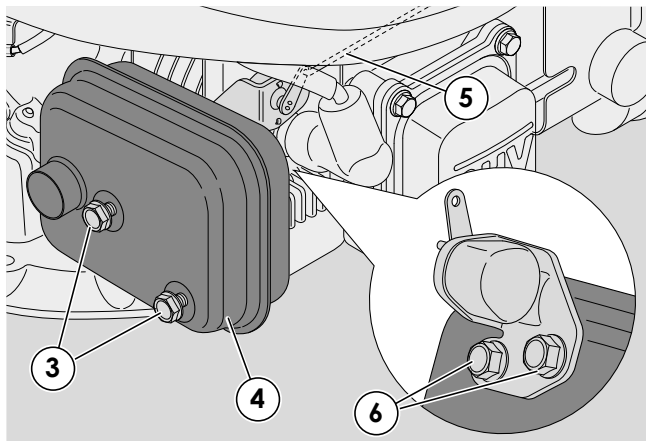
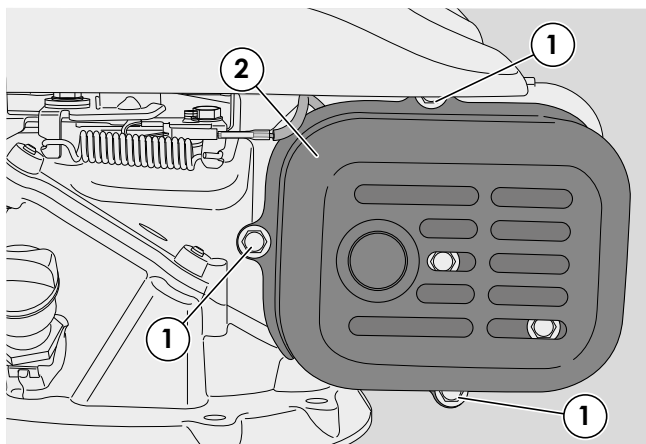

#### 13.1. Removing and replacing the muffler

1 - Remove the three screws (1) that fix the guard (2) to the muffler.

2 - Remove the two screws (3) securing the muffler (4) and pull it out by releasing the lever (5) from the AUTO-CHOKE system.

3 - Loosen the two screws (6) and remove the AUTO-CHOKE system from the muffler.

4 - Remove the gasket (7).

5 - On assembly:

- thoroughly clean the cylinder contact surface, removing all deposits or fragments on the heat-proof baffle;
- always replace damaged mufflers;
- replace the gasket (7) if damaged;
- perform the disassembly operations in reverse order by tightening the screws (1), (3) and (6) to the prescribed values.

#### Tightening torques

1	Muffler protection fixing screws	8-12 Nm
3	Muffler fixing screws	8-12 Nm
6	Fixing screw AUTO-CHOKE	5-7 Nm

### 14. ENGINE BLOCK - External operations

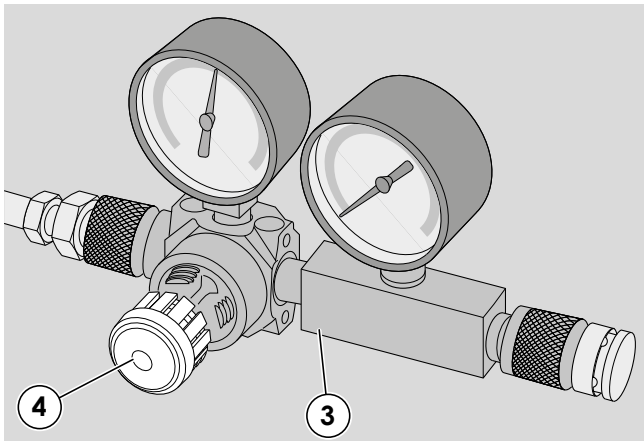
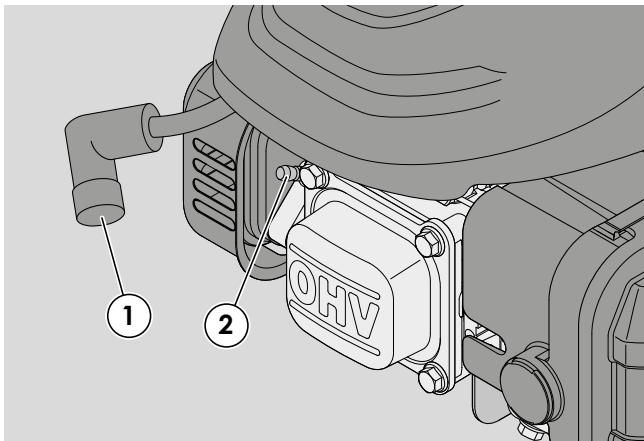

#### 14.1. Checking the heating unit seal



1 - Remove the cap (1) and take out the spark plug (2).

2 - Manually set the piston to the TDC (Top Dead Centre) of the compression stroke so that both valves are closed.

3 -  Screw the terminal of the compression testing tool (3) into the spark plug hole and connect the supply pipe to a compressed air socket with a pressure of approximately 4 bar (58 psi).

4 - On opening the air tap (4), the manometer gauge on the engine side should position itself in the green zone and remain there for about 30 seconds. If the gauge falls rapidly it means that the compression is poor.

 **NOTE: Lack of compression could be due to:**

- incorrect valve clearance [ 14.2];
- lack of seal in the valves [ 15.4];
- piston rings worn [ 15.3].

5 - Refit the spark plug (2) and close it to the indicated couple.

### 14. ENGINE BLOCK - External operations

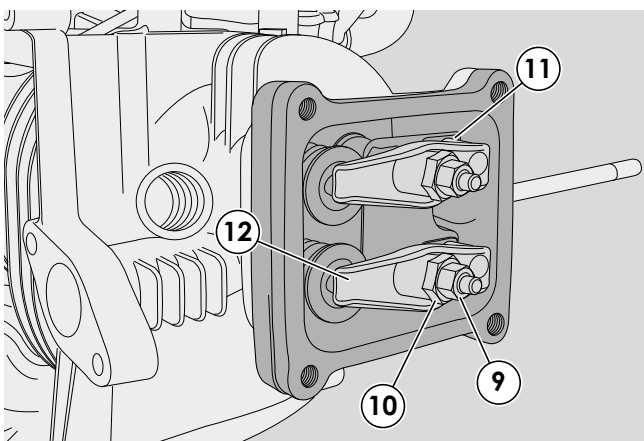
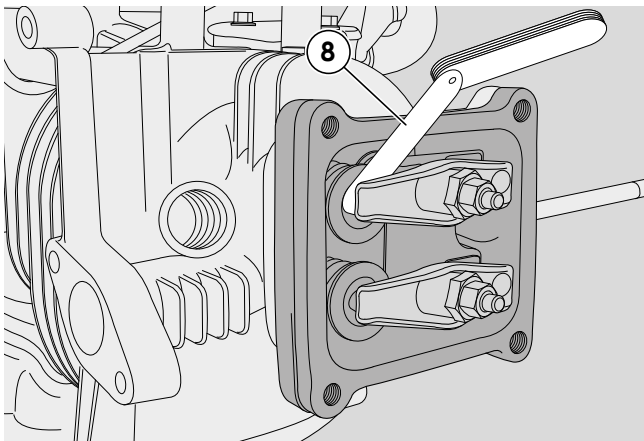
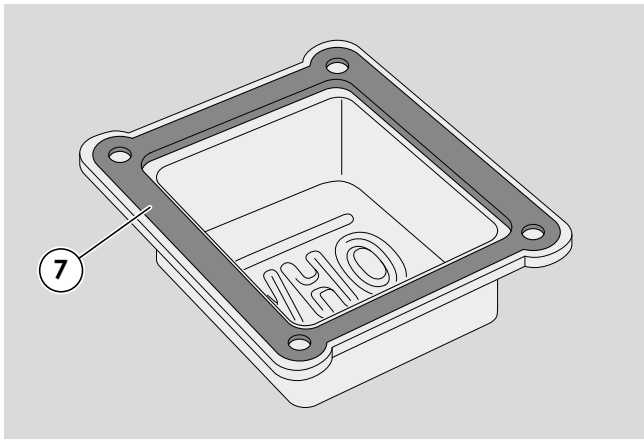
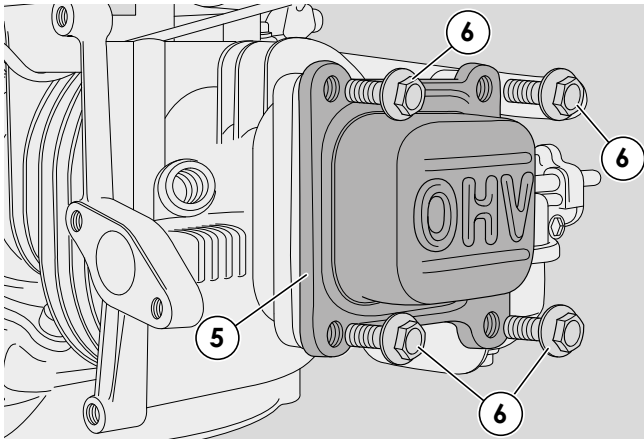

#### 14.2. Adjusting the valve clearance



**WARNING:** The adjustment must be made with the engine is cold.

1 - Remove the cover and demount the spark plug [ [👉 14.1].

2 - Remove the cover (5) which is secured with four screws (6) and remove the gasket (7).

3 - Manually set the piston to the TDC (Top Dead Centre) of the compression stroke so that both valves are closed.

4 - Use a feeler gauge (8) to check the gap between the rocker arm and the tip of the valve stem; the gauge should pass between without forcing and without a further gap.

5 - Slack is adjusted by loosening the nut (9) and using suitably adjusting the register nut (10) to obtain the following values:

**Inlet - IN = 0,10 - 0,15 mm**  
**Exhaust - EX = 0,15 - 0,20 mm**

6 - Following adjustment, check that the pushrods (11) are properly inserted in the rocker arm housings (12) and always fully tighten the dowel (9).

7 -  When reassembling check the condition of the gasket (7) of the cover (5) and replace it if it is damaged. Tighten the "cross" screws (6) to the indicated values.

8 - Assemble the spark plug [ [👉 14.1].

### 14. ENGINE BLOCK - External operations

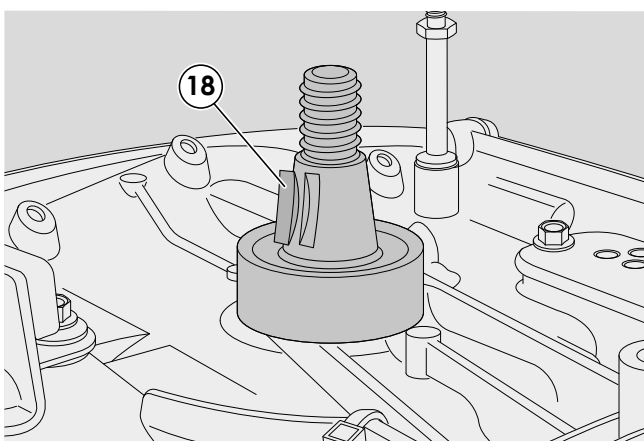
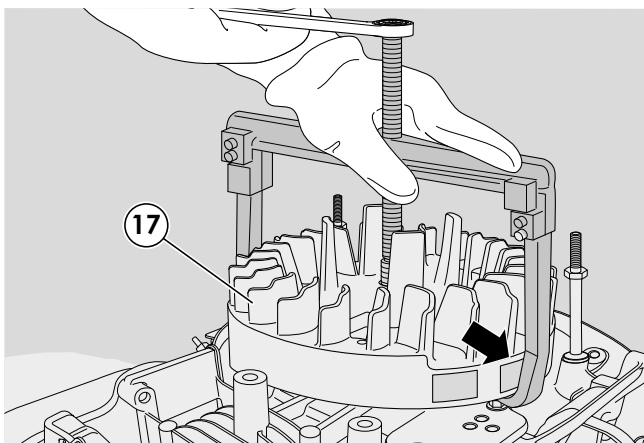
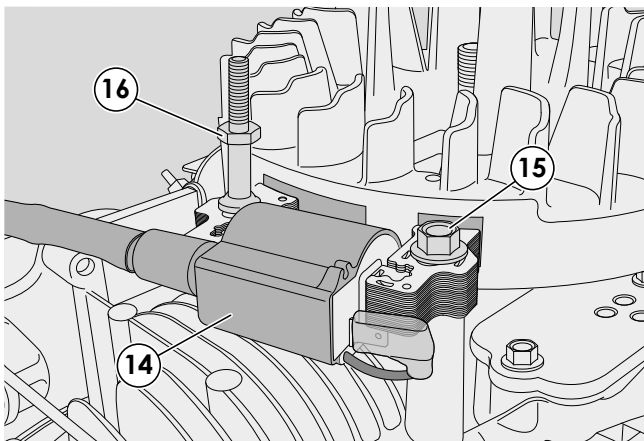
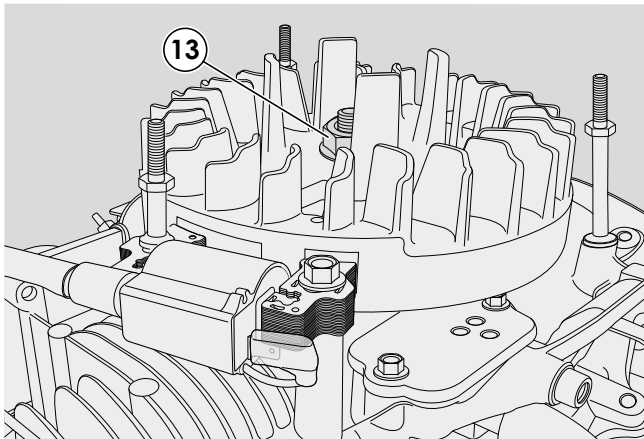

#### 14.3. Dismantling and replacing the flywheel

1 - Remove the starter assembly [ [🔧 6.1] ] and remove the conveyor.

2 - Operate the exhaust brake.

3 - Using an airgun, undo the nut (13).

4 - Undo the screw (14) and the stud (15) and remove the electronic coil (16).

5 -  Using a suitable extraction tool, remove the flywheel (17) as indicated in the diagram.

**NOTE: The extractor must be placed at the magnet and 180° on the opposite side, using the axis of the key on the motor shaft as a reference.**

Ensure that the engine shaft key is retained.

**NOTE: If it is difficult to disassemble the flywheel, use a hammer and hit the extractor screw.**

6 - When fitting the flywheel check that the key (18) is in good condition and replace it, if deformed. Close the nut (13) to the indicated couple.

7 - Refit the coil (14), tightening the screw (15) and the stud (16) to the torque indicated.

8 - Readjust the airgap until it is correct [ [🔧 11.2] ].

9 - Re-assemble the conveyor and the starter unit [ [🔧 6.1] ].



### 14. ENGINE BLOCK - External operations

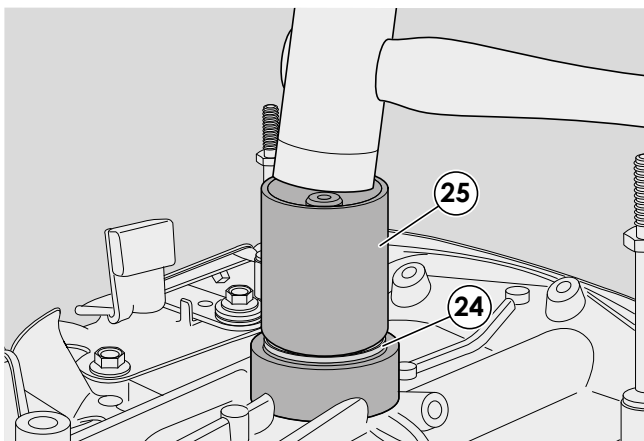
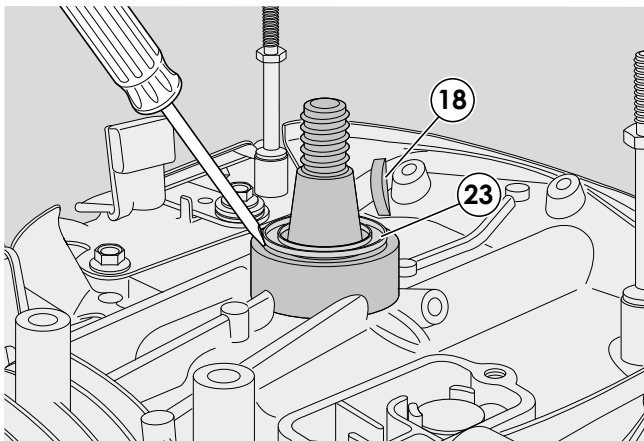
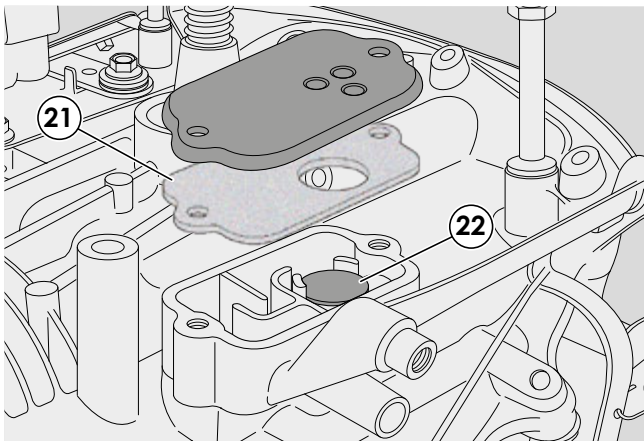
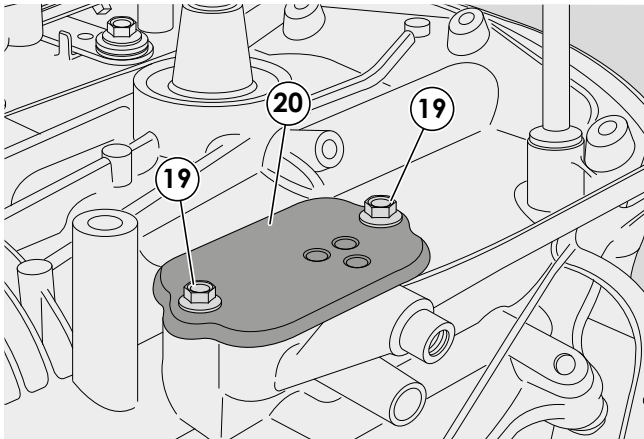

#### 14.4. Blow-by check

- 1 - Remove the flywheel [🔧 14.3].
- 2 - Loosen the screws (19) that secure the closing plate (20).
- 3 - Remove the cork gasket (21).
- 4 - Make sure that the disc valve (22) is not blocked or deformed. Replace it if necessary. If necessary, wash with water and neutral detergents.
- 5 - 🔄 If necessary, replace the cork gasket (21) and reassemble the closing plate (20), tightening the screws with the indicated torque.
- 6 - Refit the flywheel [🔧 14.3].

#### 14.5. Replacing the upper compression ring of the engine shaft (flywheel side)

- 1 - Remove the flywheel [🔧 14.3].
- 2 - Take out the spline key (18).
- 3 - Use a thin screwdriver inserted under the sealing lip to extract the oil seal ring (23).
- 4 - The new ring (24) must be inserted with the help of a pipe (25) with a diameter of approximately 35-40 mm, taking care not to damage the sealing lip.
- 5 - Refit the key (18) and the flywheel [🔧 14.3].

### 14. ENGINE BLOCK - External operations

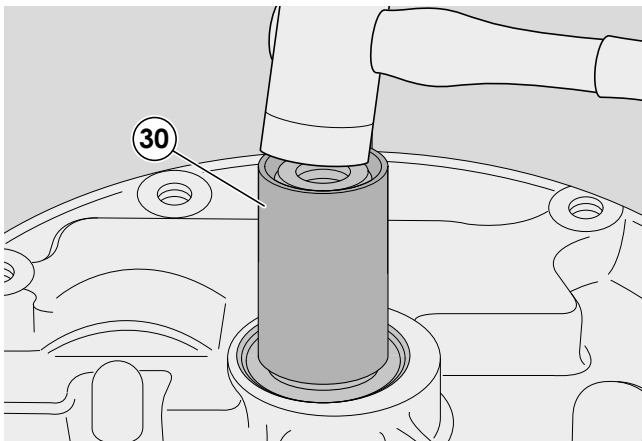
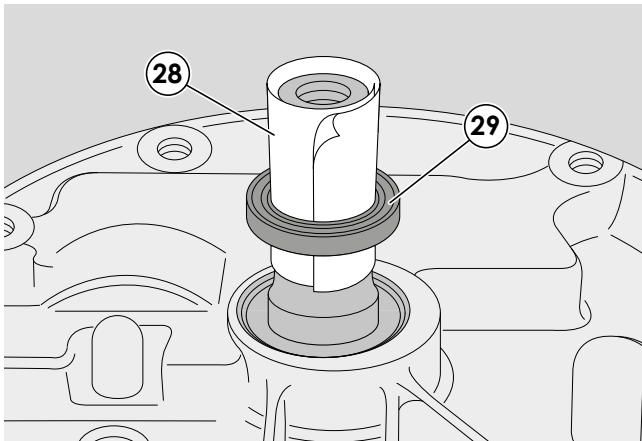
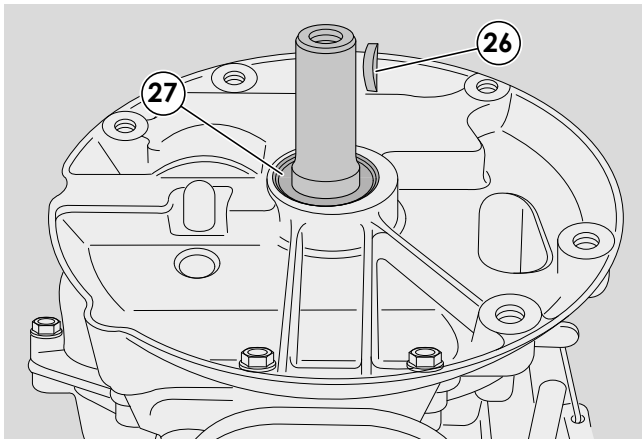

#### 14.6. Replacing the lower compression ring of the engine shaft (sump side)



**NOTE - Remove the motor from the lawnmower;**  
 - drain all the oil from the sump;  
 - drain the petrol from the tank and carburettor tray;  
 - turn the motor 180°.

1 - Take out the spline key (26).

2 - Use a thin screwdriver inserted under the sealing lip to extract the oil seal ring (27).

3 - Make a paper tube (28) around the shaft to protect the sealing lip and insert the new ring (29) so that it enters its housing.

4 - Complete the insertion with the help of a pipe (30) of a diameter of approximately 30-35 mm.

#### Tightening torques

2	Spark plug tightening torque	25-32 Nm
6	Valve cover fixing screws	8-12 Nm
13	Flywheel fixing nut	55-65 Nm
19	Blow-by closure plate screws	5-7 Nm

#### Technical information

Inlet valve clearance	0,10-0,15 mm
Exhaust valve clearance	0,15-0,20 mm

#### Special equipment

- 3 Compression testing tool



### 15. ENGINE BLOCK - Overhauling internal parts

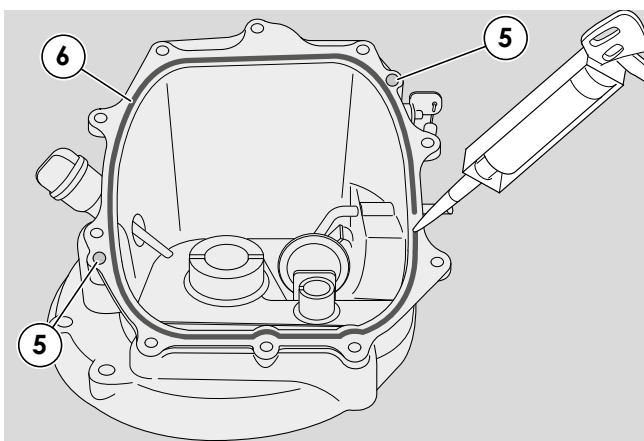
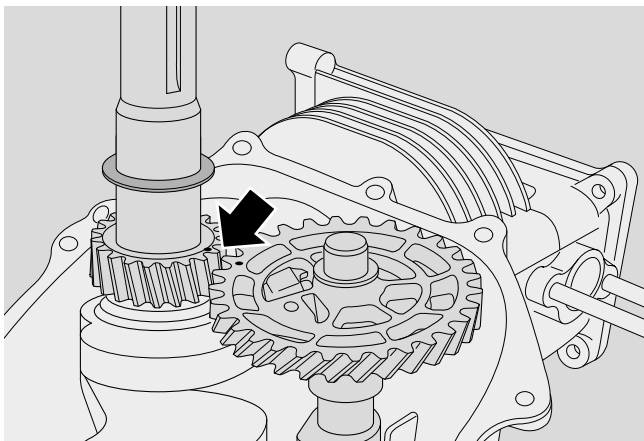
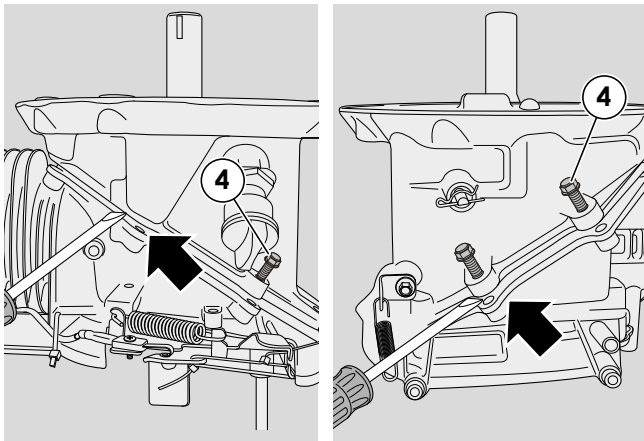
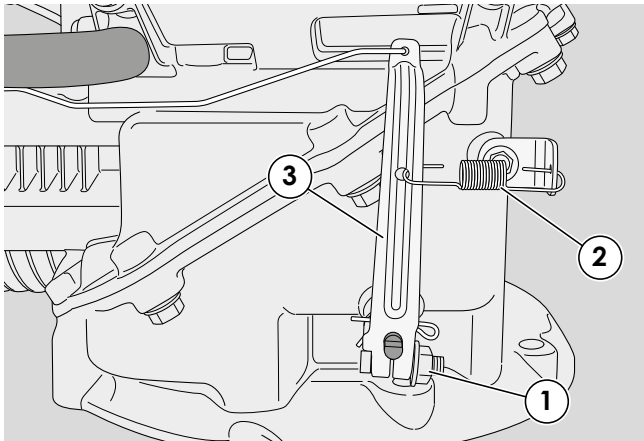

All the following operations on the grass cutter necessitate the removal of the motor.

#### 15.1. Carter opening

1 - Loosen the lever fixing nut (1), release the spring (2) and remove the control lever (3).

2 - Position the engine on a stable support and remove the sparkplug.

Bring the piston to the TDC (Top Dead Centre).

3 - Turn the engine upside down and place it with the shaft pointing upwards.

4 - Loosen the ten screws (4), retrieving the two centring pins (5), and remove the engine sump with the help of the levers in the two points indicated.

5 - Check the timing between the engine shaft and camshaft, partially removing the shim ring;

If necessary, re-set the phasing, referring to the indications provided.

6 - On assembly, follow the steps described in reverse and:

- clean the contact surfaces, removing any remaining silicone;
- evenly distribute the silicone seal (THREE BOND 1207) (8) as shown in the figure;
- ensure that the two centring pins (7) are properly inserted;
- always replace the compression ring from the sump side [\[ 14.6 \]](#).
- close the screws (6) intersection lock sump to the indicated couple;

7 - After installing the engine on the machine:

- refill the sump and make sure that the filler plug is tight.

- check correct the brake control cable adjustment [\[ 12.1 \]](#).

8 - Following reassembly, it is advisable to check the engine's rpm [\[ 9.1 \]](#).

### 15. ENGINE BLOCK - Overhauling internal parts

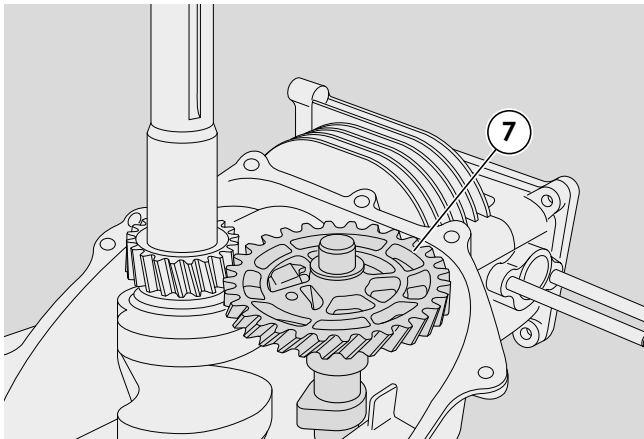



#### 15.2. Dismantling and checking the camshaft and counterweight governor

1 - Bring the piston to the TDC (Top Dead Centre).

2 - Open the crank case  15.1).

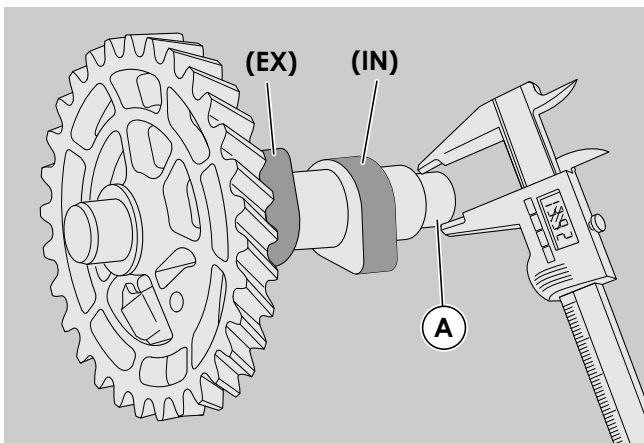
3 - Remove the camshaft (7).



4 -  Measure seat (A) of the camshaft, checking for wear and tear. The value must not be lower than 13,92 mm.

5 - Measure the cams (IN and EX) on the camshaft, checking for wear. The value must not be lower than 27,30 mm (IN) and 27,40 mm (EX).

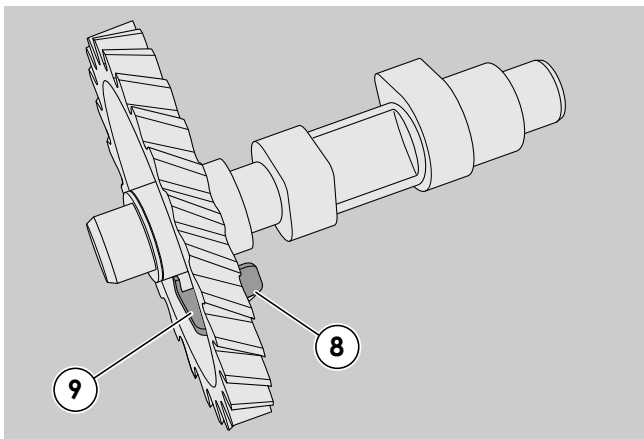

6 - Check the regular movement of the pressure reducer (8) and the efficiency of the spring (9); the whole group must always be replaced in the case of breakage or irregular operation of the pressure reducer.

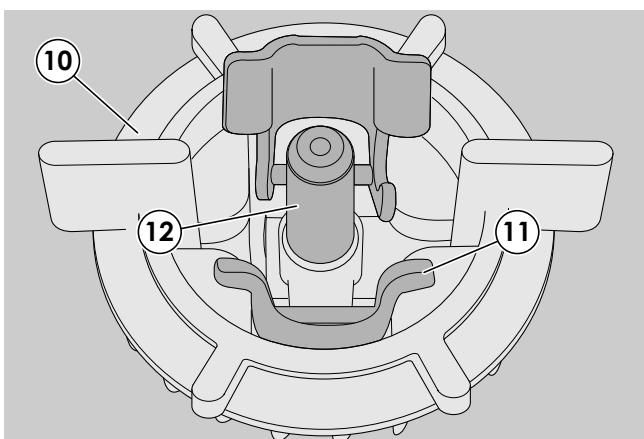

7 - Check that the irregular centrifugal (10) that are not present ruptures of the lubrication pallets.

8 - Turn the governor's gears quickly and check that the counterweights (11) expand correctly, causing the pin (12) to be moved axially.

### 15. ENGINE BLOCK - Overhauling internal parts

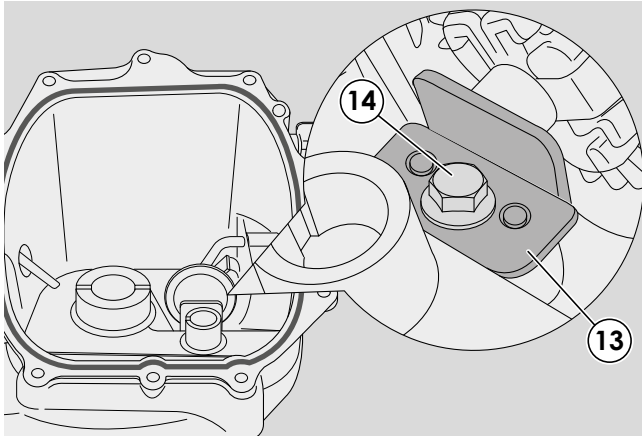

9 - In the case of breakage or irregular operation of the counterweights the whole group, fixed by a plate (13) and a screw (14) must be replaced.

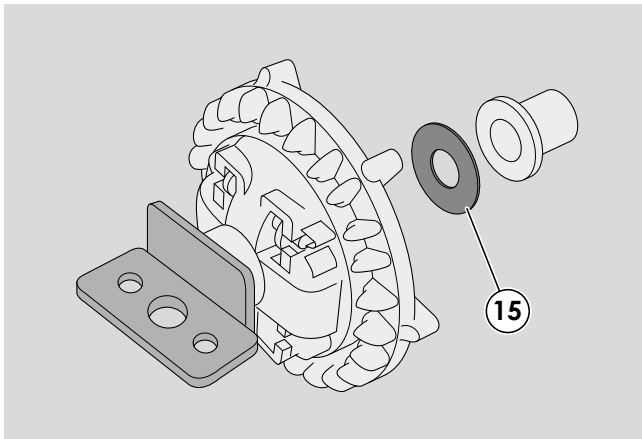

10 - When installing the new unit, take care to position the washer (15) correctly on the opposite side.

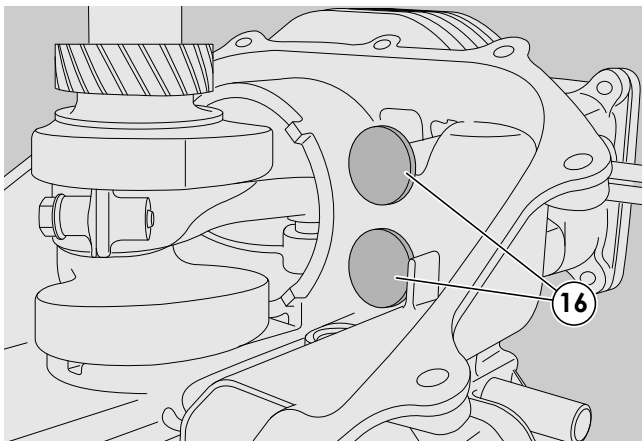

11 - Before fitting the camshaft ensure that the two tappets (16) are correctly housed in their seats.

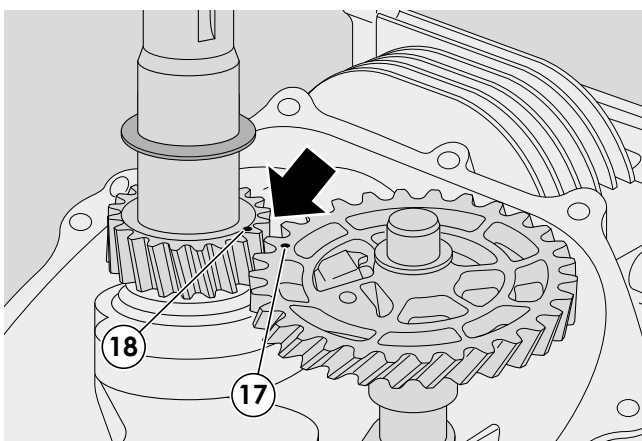

12 - When refitting the camshaft, maximum care must be taken to match up the two references (17) and (18) punched on the gears, so as to ensure correct distribution phasing.

13 -  During assembly, refer to the operations in section [\[15.1\]](#) always remembering to replace the silicone gasket (6) between the sump and the guard.

### 15. ENGINE BLOCK - Overhauling internal parts

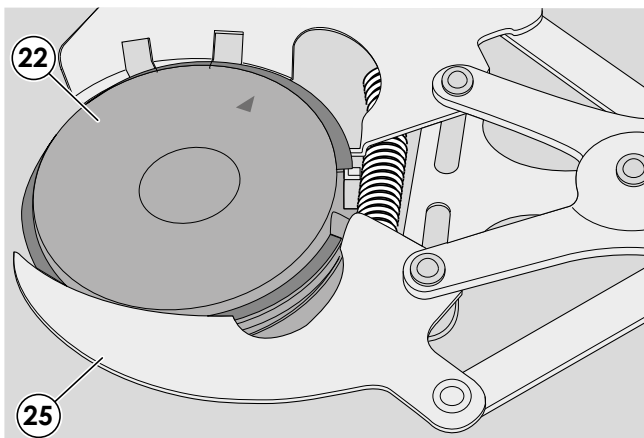
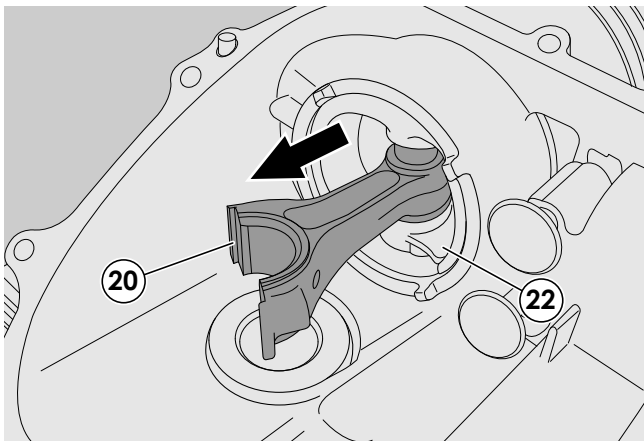
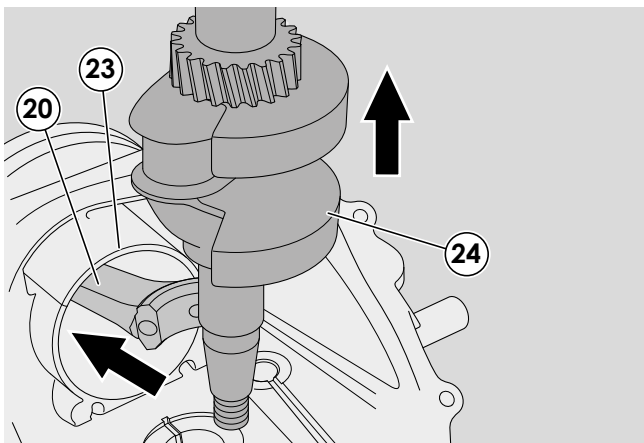
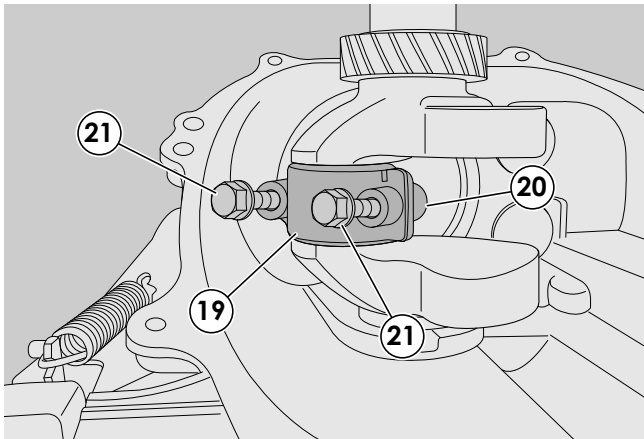

#### 15.3. Dismantling and checking the piston, piston rings, connecting rod and engine shaft



**NOTE** - These paragraphs describe all the operations for checking and overhauling the thermal components of the engine; it is left to the operator to assess the advisability of performing all the operations described or only part of them, depending on the type of engine problems encountered.

1 - Remove the flywheel [ 14.3].

2 - Open the cover [ 15.1].

3 - Remove the camshaft [ 15.2].

4 - Dismantle the connecting rod (19) cap (20), fixed with two screws (21) (take note of any reference marks for refitting).

5 - Push the connecting rod (20) so as to ensure the piston (22) enters the cylinder (23) fully.

6 - Pull the engine shaft (24) out completely.

7 - To remove the piston (22) pull the connecting rod (20) as shown in the figure.

8 - Use the special expanding tool (25) to remove the two compression rings and the oil scraper ring from the piston (22).

9 - Carefully remove all carbon deposits from the compression rings, the inside of the cylinder and the piston head.

### 15. ENGINE BLOCK - Overhauling internal parts

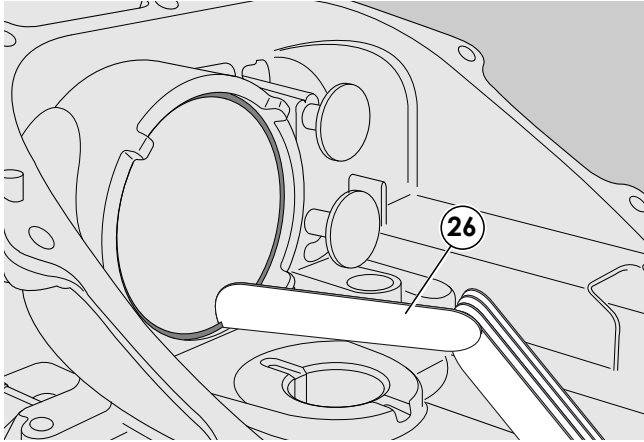

10 - To check the wear in the compression rings, insert them one at a time into the cylinder (23) by about 10-15 mm and measure the gap between the two ends with a feeler gauge (26); the rings must be replaced if the gap is more than 1,0 mm.



**NOTE - If a gap of more than 0.4 mm is measured with new rings it means that the cylinder is worn beyond the acceptable limits and must be replaced. The cylinder must be replaced if it shows striping due to a seizure.**

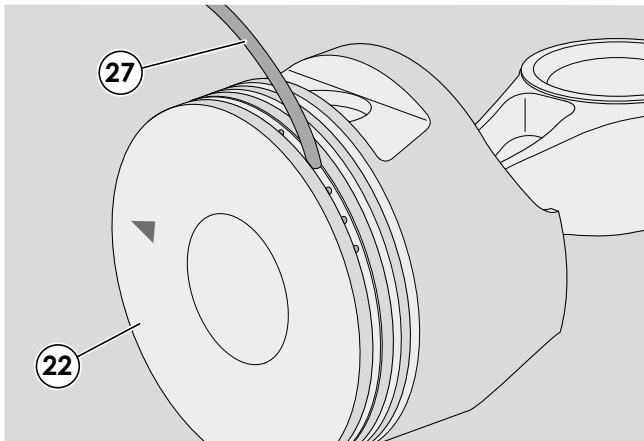

11 - Use a section of an old ring (27) to carefully clean the inside of the piston (22) ring housings, ensuring that the oil passage holes are not blocked.

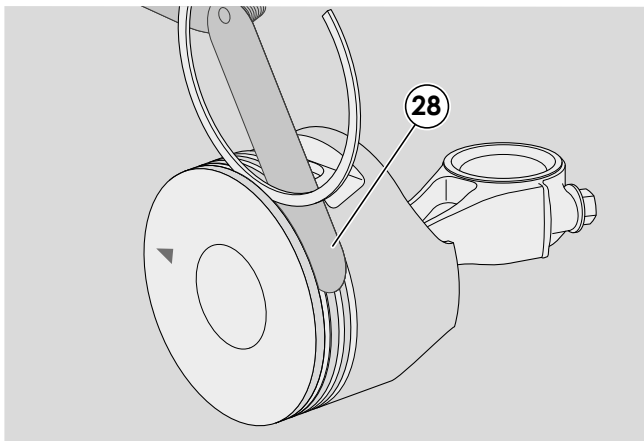

12 - To check the wear in the piston ring housings, fit a new ring and measure the residual space with a feeler gauge (28). The piston must be replaced if it is greater than 0.15 mm in the two compression ring housings.

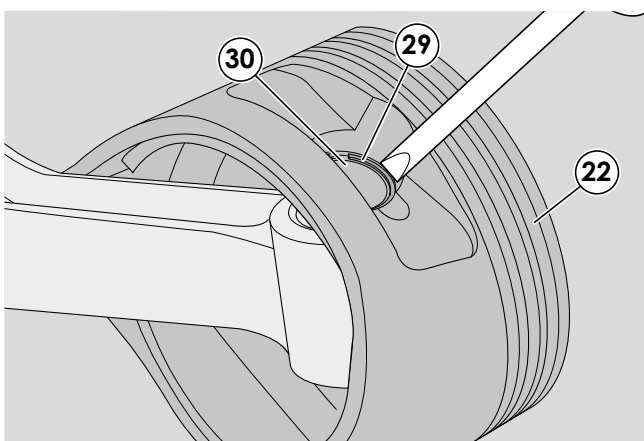

13 - Use a screwdriver to remove the clamping ring (29) and remove the gudgeon pin (30) from the piston (22).

### 15. ENGINE BLOCK - Overhauling internal parts

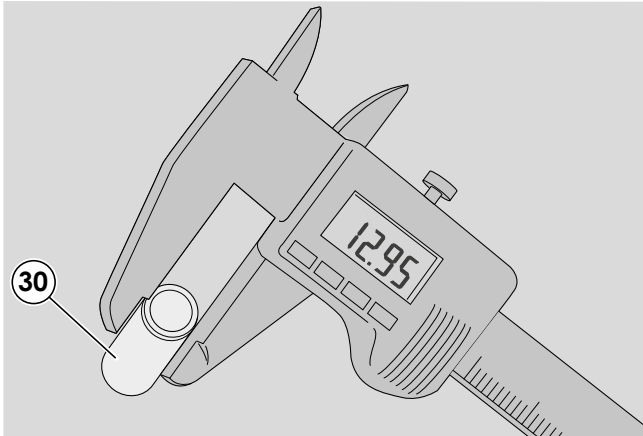

14 - Check the diameter of the gudgeon pin (**30**) in several places and replace it if it is less than 12.95 mm, even at a single point.

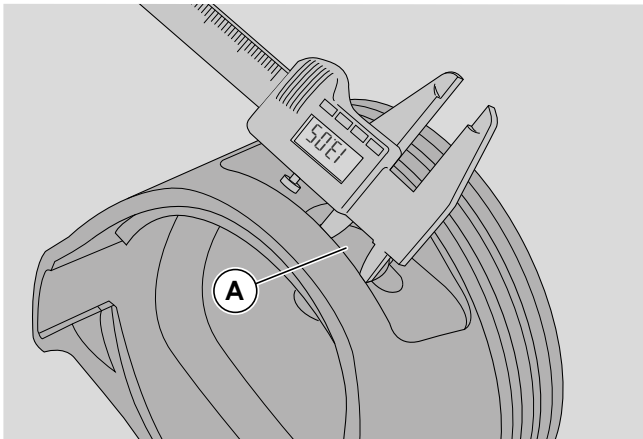

15 - Check the diameters of the gudgeon pin housings (**A**) on the piston (**22**) and replace the piston if they are more than 13.05 mm, even at a single point.

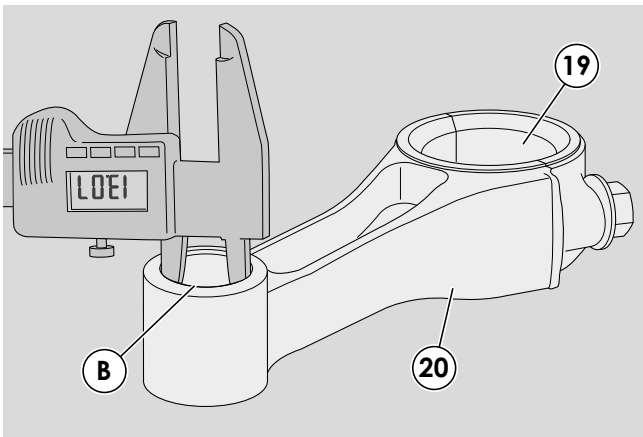

16 - Fit the cap (**19**) to the connecting rod (**20**) and check the diameter from the gudgeon pin side and the crank side; replace the connecting rod if the values are greater than:

- B** : 13,07 mm on the gudgeon pin side;
- C** : 26,07 mm on the crank side.

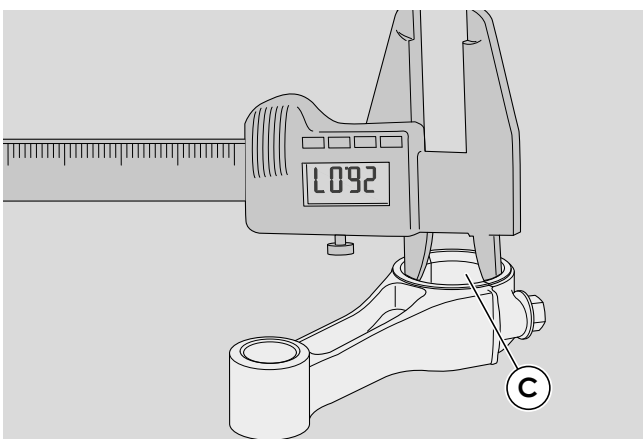

If the connecting engine shaft is outside measurement tolerances or has small scratches or marks, it is necessary to replace it.



### 15. ENGINE BLOCK - Overhauling internal parts

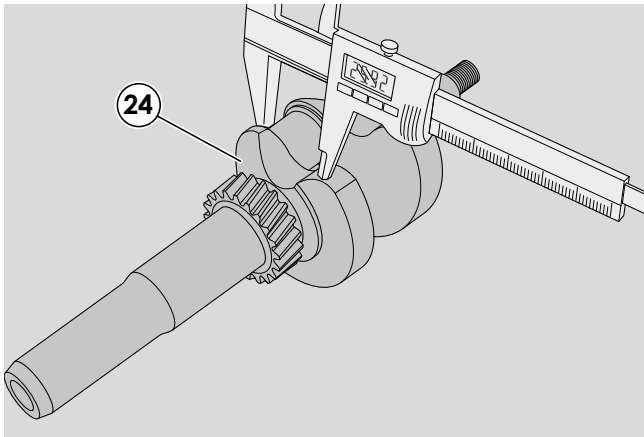

17 - On the engine shaft (24), removed beforehand, use a digital gauge to check the diameter of the connecting rod pin.

The value must not be less than 25,92 mm or the engine shaft will have to be replaced.



**NOTE** - In the case of seizing, the manifolds can be polished with fine emery cloth, only removing foreign matter and checking that the final size remains within the aforementioned limit.

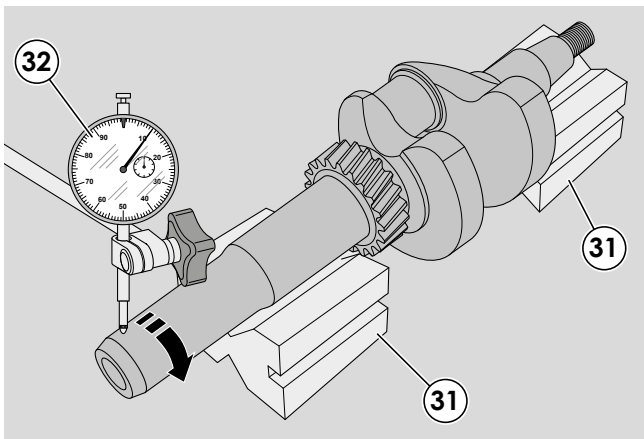

18 - To check the alignment between the manifolds and the protruding part of the shaft, place the engine shaft on two prismatic guides (31) and, with the help of a comparator (32) placed at the end, check the displacement by rotating the shaft. The shaft must be replaced if the displacement exceeds 0.10 mm.



**IMPORTANT:** A bent shaft must never be repaired!



**WARNING - DANGER:** A bent shaft causes abnormal vibrations and could be dangerous when the machine is used!

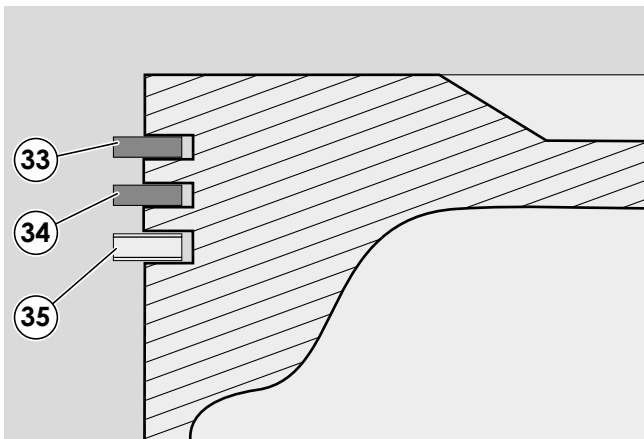

19 - To refit the rings to the piston, first fit the three oil scraper rings (33), then the ring with a round edge (34) and finally the ring with a sharp edge (35), being careful over the markings (which must face the piston head) and in arranging the gaps to ensure that they are not aligned with each other;

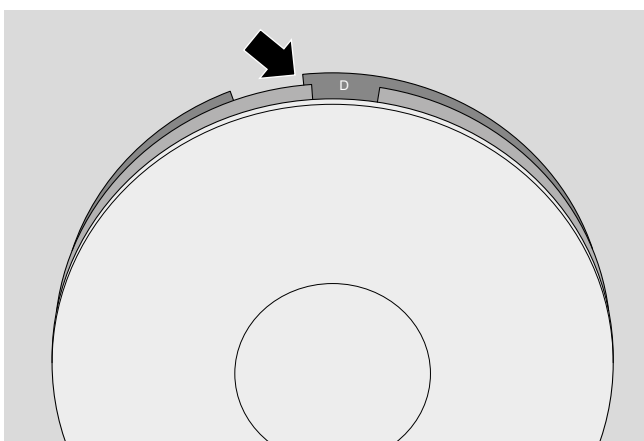



### 15. ENGINE BLOCK - Overhauling internal parts

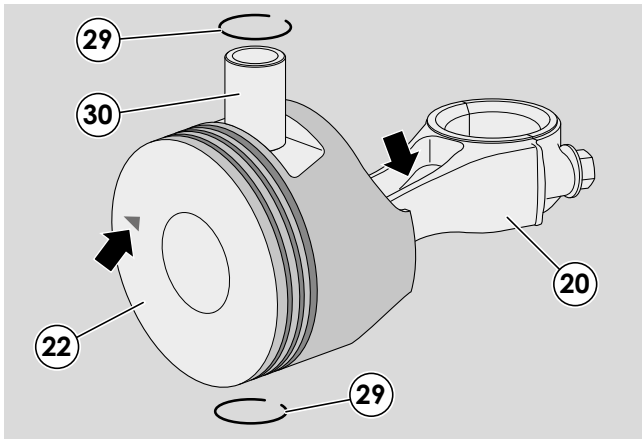

20 - Fit the connecting rod (20), gudgeon pin (30) and clamping rings (29) to the piston (22).



**NOTE** - The marking on the piston must be directed towards the intake.

The connecting rod must be mounted with the marking (36) facing upwards.

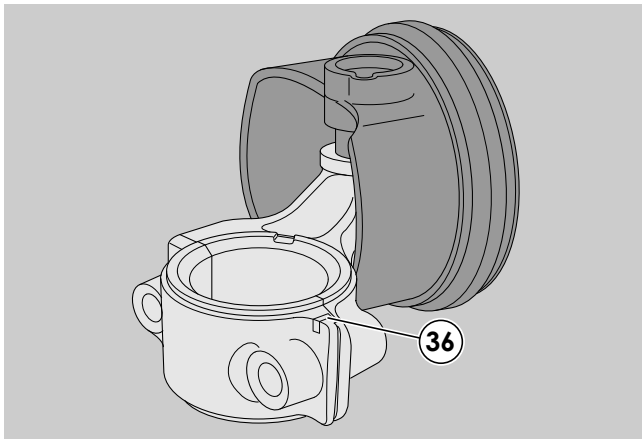

21 - Put the piston into the ring compression tool (37).

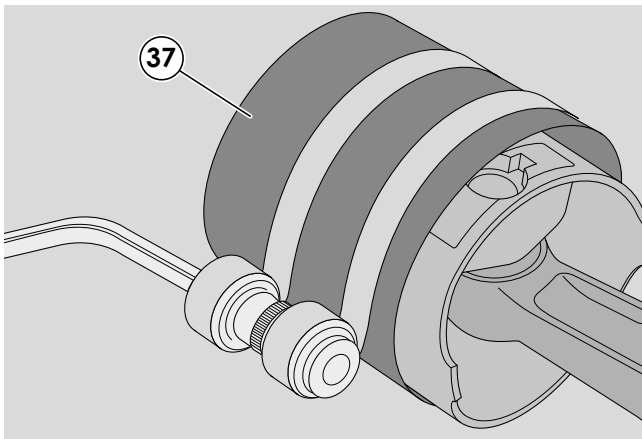

22 - Oil the inside of the piston liberally and insert the piston, with the marking facing the exhaust.

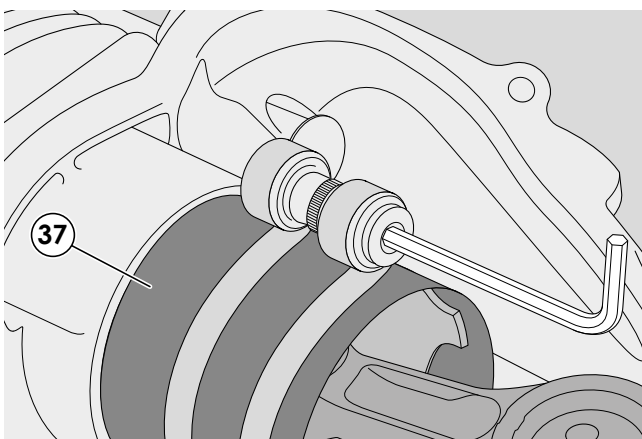

### 15. ENGINE BLOCK - Overhauling internal parts

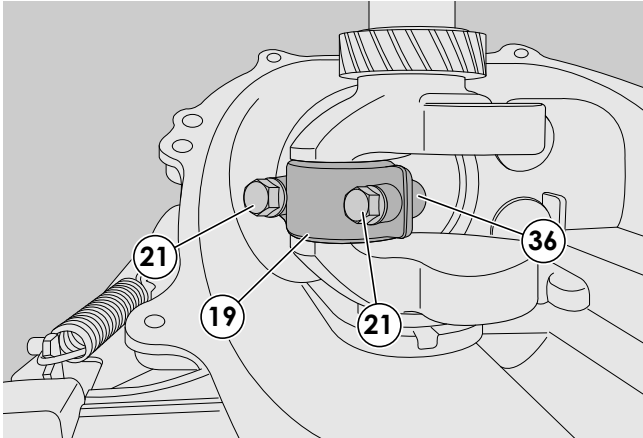

23 - Mount the engine shaft (24) and the connecting rod cap (19) with the relative screws (21), taking care with the position references (36) so as to avoid inverting the mounting direction of the cap.  
**Close the screws (21) to the indicated couple.**

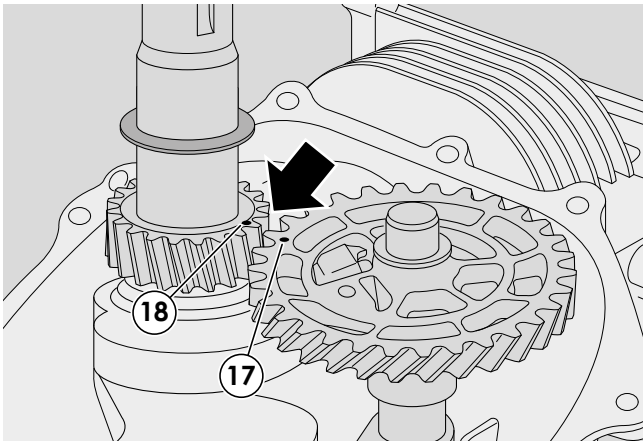



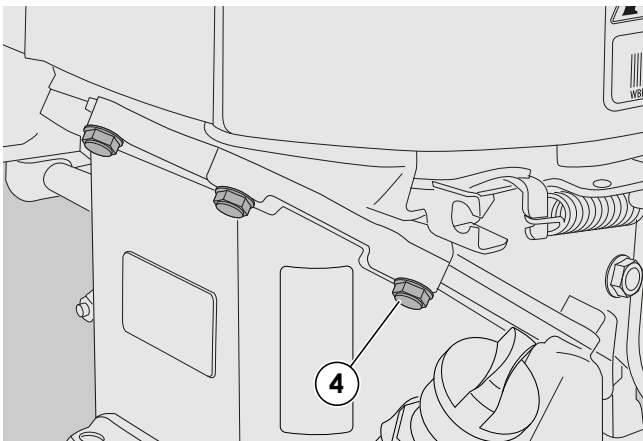

24 - After having fixed the connecting rod cap, take the greatest care to ensure that the two position references (17) and (18) punched on the engine shaft and camshaft gears, coincide, ensuring the correct distribution phasing.



25 - Close the carter and fix the screws (4) to the indicated couple  15.1.

26 - Whenever the engine shaft is dismantled and refitted, it is always necessary to:

- replace the sealing ring on the flywheel side  14.5;
- replace the sealing ring on the sump side  14.6.

27 -  During assembly, refer to the operations in section  15.1 always remembering to replace the silicone gasket (6) between the sump and the guard.

### 15. ENGINE BLOCK - Overhauling internal parts

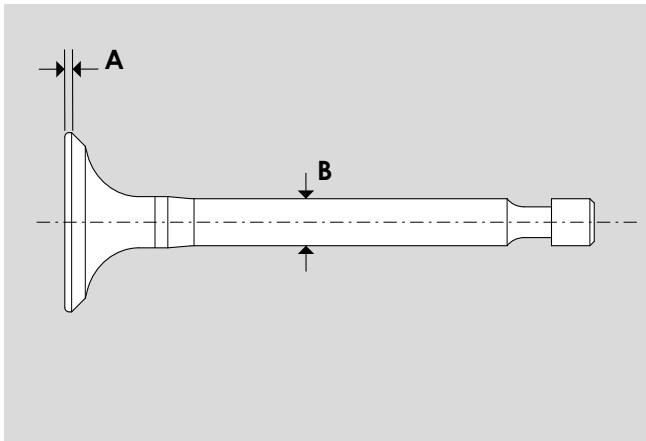
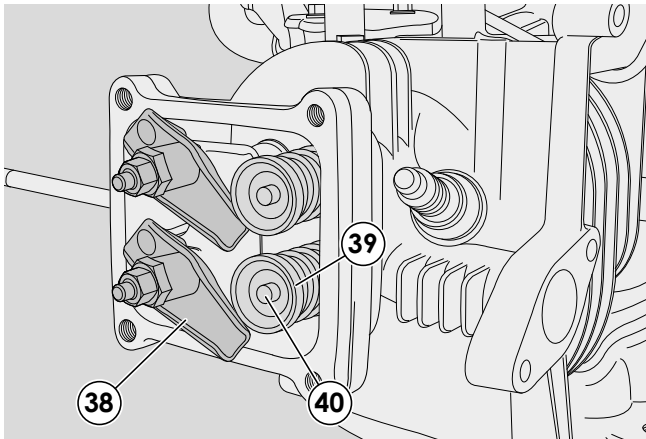

#### 15.4 Overhauling the valves



**NOTE** - These paragraphs describe all the operations for checking and overhauling the valves;

*it is left to the operator to assess the advisability of performing all the operations described or only part of them, depending on the type of engine problems encountered.*

1 - Remove the starter assembly [ [🔧] 6.1] e sfilare il convogliatore.

2 - Open the crank case [ [🔧] 15.1] and remove the piston [ [🔧] 15.3].

3 - Move the rocker arms (38); press down the spring seal cap (39) and move it sideways to remove from the valve stem (40).

**IMPORTANT** - The intake and exhaust valves are of different sizes.

4 - Use an emery cloth to remove all incrustations from the valve head and check the thickness of the rim (A); the valve must be replaced if the margin (A) is less than 0,50 mm or if it shows signs of burning.

5 - Check the diameter of stem (B) in several points and replace the valve if it is less than the following, even if only in one point:

**5,32 mm (inlet - IN)**

**5,27 mm (exhaust - EX)**

### 15. ENGINE BLOCK - Overhauling internal parts

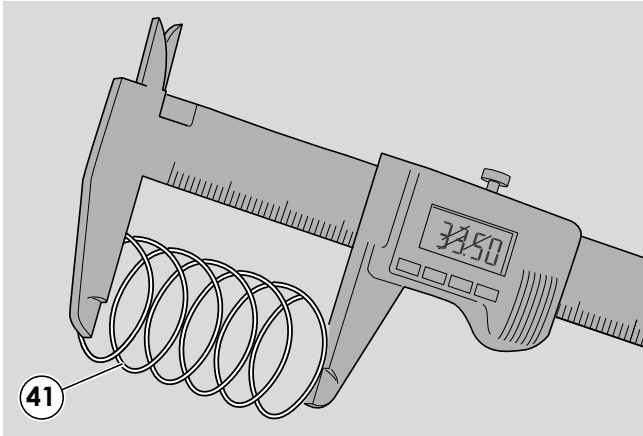

6 - Check the free length of the spring (41) and replace the spring if it is less than 33,50 mm.

7 - When mounting:

- carefully clean the valve guides and housings of any foreign body;

- apply a film of oil on the valve stems before inserting them in their respective housings;

- ensure the proper position of the intake valve and exhaust valve, which can be noticed by the different sizes (Intake: larger, Exhaust: smaller).

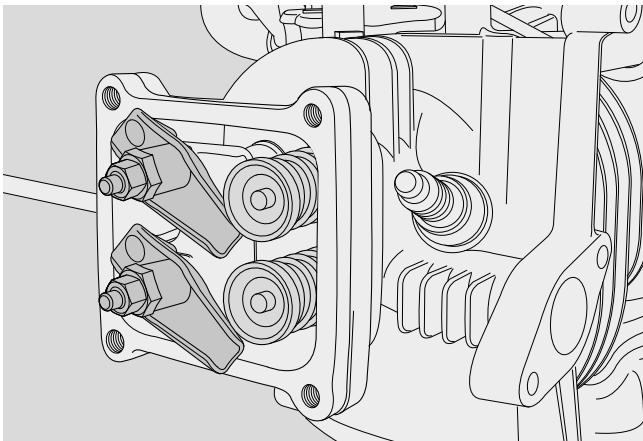
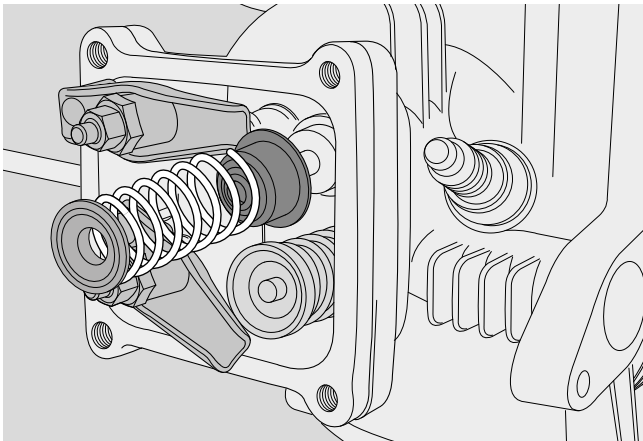

8 - Reassemble the intake valves

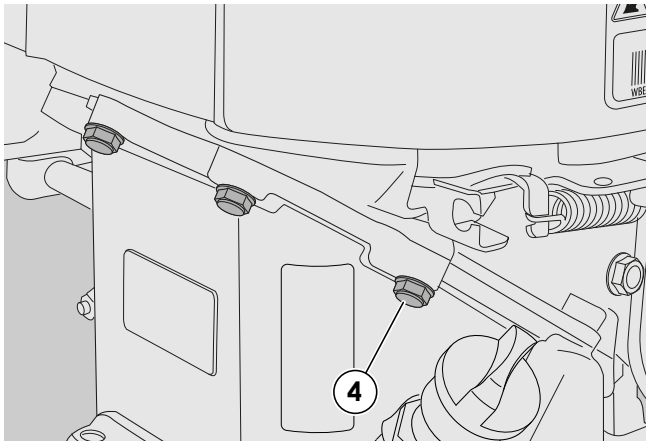

### 15. ENGINE BLOCK - Overhauling internal parts



9 - Close the carter and fix the screws (4) to the indicated couple  15.1).

10 -  During assembly perform the operations indicated in section  15.1 always remember to replace the silicone gasket (6) between the sump and the casing.

11 - Re-assemble the conveyor and the starter unit  6.1).

#### Tightening torques

<b>4</b>	Union screws under carter and sump	8-12 Nm
<b>14</b>	Counterweight governor fixing screw	5-7 Nm
<b>21</b>	Fixing screws lower connecting rod cap	11-13 Nm

#### Technical information

Oil sump capacity	0,50 litri
Diameter Pump seat on camshaft	13,92 mm
Diameter aspiration cam	27,30 mm
Diameter discharge cam	27,40 mm
Maximum segments gap in the cylinder	1,0 mm
Max. compression ring axial gap	0,15 mm
Minimum gudgeon pin diameter	12,95 mm
Max. gudgeon pin housing diameter on piston	13,05 mm
Max. connecting rod diameter	
gudgeon pin side	13,07 mm
crank side	26,07 mm
Diam. connecting rod's pin on engine shaft	25,92 mm
Verify the engine shaft extremes	0,10 mm
Minimum inlet valve stem diameter	5,32 mm
Minimum exhaust valve stem diameter	5,27 mm
Valve head margin min. thickness	0,50 mm
Minimum valve spring length	33,50 mm



















#### Special equipment

- 25** Piston ring removal expander
- 37** Piston ring compressing tool

### 16. TROUBLESHOOTING

PROBLEM	CAUSE	SOLUTION
<b>The engine does not start or starts badly</b>	The engine brake cable is faulty or unfastened	Adjust and/or replace the cable <a href="#">[[👉 12.1]]</a>
	The OFF microswitch is faulty	Replace the whole shut-down group <a href="#">[[👉 12.2]]</a>
	Coil earth connection	Check electrical cabling of earth wire <a href="#">[[👉 11.1]]</a>
	Earth wire is flattened	Replace the whole shut-down group <a href="#">[[👉 12.4]]</a>
	The coil is faulty and does not supply current or the air gap is too large	Check coil <a href="#">[[👉 11.2]]</a>
	Carburettor dirty	Check and clean the carburettor <a href="#">[[👉 8.1]]</a>
	Poor seal of carburettor needle valve	Clean the carburettor housing and needle valve <a href="#">[[👉 8.1]]</a> or replace the carburettor <a href="#">[[👉 8.2]]</a>
	The spark plug is badly connected or faulty	Check spark <a href="#">[[👉 11.1]]</a> or replace spark plug
	Blocked air filter	Execute the filter cleaning <a href="#">[[👉 7.1]]</a>
	Valve malfunction	Check the valve clearance <a href="#">[[👉 14.2]]</a>
	Insufficient pressure	Check tightness of cylinder head screws, replace washer if necessary. Check wear and tear of the piston rings <a href="#">[[👉 15.3]]</a>
	AUTO-CHOKE malfunction	AUTO-CHOKE check and/or replacement <a href="#">[[👉 10.1]]</a>
The Primer is faulty	Check the operating efficiency of the petrol pipe	
<b>Starting is difficult and strains the rope</b>	Presence of oil in the combustion chamber	Clean the combustion chamber
	Pressure reducer fault	Check the pressure reducer and counterweights <a href="#">[[👉 15.2]]</a>

### 16. TROUBLESHOOTING

PROBLEM	CAUSE	SOLUTION
<b>The engine starts but does not run</b>	The tank cap has a clogged breather pipe	Clean and/or replace the cap  <b>5.3]</b>
	Insufficient pressure	Check correct valve operation  <b>15.4]</b> . Check that the spark plug is secured  <b>11.1]</b> . Check for any cracks in the casing. Check wear and tear of the piston rings  <b>15.3]</b>
	Exhaust is blocked	Check that there is airflow through the exhaust system and replace if necessary  <b>13.1]</b>
<b>The engine is inefficient or the runs irregularly</b>	The governor malfunctions or there is a problem with the rods	Check the entire governor system  <b>9]</b>
	Air seepage in the carburettor	Replace the carburettor gaskets  <b>8.1]</b>
	Carburettor dirty	Check and clean the carburettor  <b>8.1]</b>
	Insufficient pressure	Check correct valve operation  <b>15.4]</b> . Check that the spark plug is secured  <b>11.1]</b> . Check for any cracks in the casing. Check wear and tear of the piston rings  <b>15.3]</b>
	The coil air gap has been poorly adjusted	Adjust the air gap  <b>11.2]</b> and if the problem persists, replace the coil  <b>11.3]</b>
	Oxidation or loosening of spark plug connections	Perform spark test  <b>11.1]</b> or replace spark plug
	AUTO-CHOKE malfunction	AUTO-CHOKE check and/or replacement  <b>10.1]</b>
<b>The engine overrevved</b>	Governor blocked due to breakage of centrifugal assembly or breakage of external governor springs. It is possible that the governor is dirty	Check the entire governor system  <b>9 and 15]</b>
<b>The engine judders</b>	Engine screws loose	Tighten the screws
	Engine shaft off-centre	Replace the engine shaft  <b>15.3]</b>
	Engine timing faulty	Check wear and tear of the connecting rod of the engine shaft, replace shaft if necessary  <b>15.3]</b>



### 16. TROUBLESHOOTING

PROBLEM	CAUSE	SOLUTION
<b>The engine does not turn off</b>	The engine brake cable is bent or jammed	Check and/or adjust the cable [ [👉 12.1]
	The earth cable is disconnected or broken	Check and/or replace oil breather tab [ [👉 11.1]
<b>The engine does not stop within 3 seconds after it has turned off</b>	Faulty or no clutch lining	Replace the engine stopping system [ [👉 12.4]
<b>The engine uses a lot of oil</b>	Faulty blow-by operation	Check and/or replace the blow-by system [ [👉 14.4]. Check the condition of the air filter [ [👉 7.1]
	Poor piston ring seal	Replace the rings [ [👉 15.3]
	Excessive gap between the guide and the inlet valve stem	Check and/or replace the valve [ [👉 15.4]
	Ring assembly error	Check the assembly of the rings [ [👉 15.3]

