

ECHO®

shindaiwa®

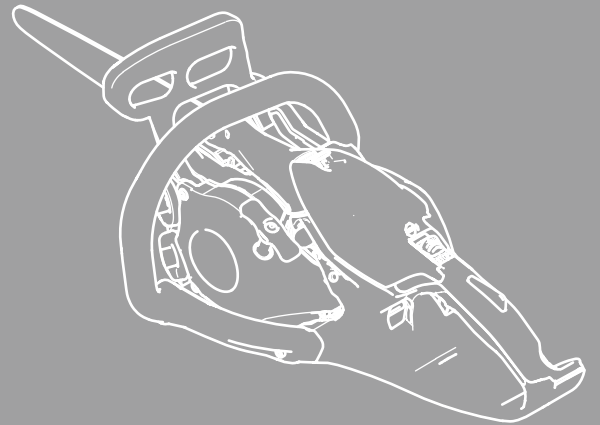

SERVICE MANUAL

ECHO: CS-2511WES

shindaiwa:

251Ws

(Serial number: 38000001 and after)

INTRODUCTION

This service manual contains information for service and maintenance of **ECHO CHAIN SAW**, model **CS-2511WES** and **shindaiwa CHAIN SAW**, model **251Ws**.

For systematic diagnosis, to avoid extra work, time loss and to meet Emission regulation, please refer to “Troubleshooting guide” that describes problems, testing, remedies and references. We recommend you make use of Operator’s Manual and Parts Catalogue together with this manual when servicing.

We are constantly working on technical improvement of our products. For this reason, technical data, equipment and design are subject to change without notice. All specifications, illustrations and directions in this manual are based on the latest product information available at the time of publication.

	Page		Page
1 SERVICE INFORMATION.....	2	6 CHAIN BRAKE SYSTEM	42
1-1 Specifications.....	2	6-1 Replacing brake lever and torsion spring	42
1-2 Technical data	3	6-2 Inspecting chain brake parts.....	44
1-3 Torque limits.....	5	7 SAW CHAIN LUBRICATION SYSTEM	46
1-4 Special repairing materials	5	7-1 Inspecting oil cap and strainer	46
1-5 Service limits.....	6	7-2 Inspecting oil tank vent.....	47
1-6 Special tools	7	7-3 Inspecting and replacing oil line.....	48
2 STARTER SYSTEM (ES-start / S-start)	8	7-4 Inspecting worm gear	49
2-1 Disassembling starter assembly	9	7-5 Cleaning and replacing auto-oiler assembly... 50	
2-2 Replacing starter rope	10	8 ENGINE	53
2-3 Assembling starter.....	11	8-1 Testing cylinder compression.....	54
2-4 Replacing starter pawl	13	8-2 Cleaning cooling air passages.....	55
3 IGNITION SYSTEM	14	8-3 Inspecting muffler and exhaust port.....	56
3-1 Troubleshooting guide	15	8-4 Testing crankcase and cylinder sealings.....	57
3-2 Testing spark.....	16	8-5 Removing engine block	58
3-3 Inspecting spark plug.....	17	8-6 Inspecting cylinder	59
3-4 Replacing spark plug cap and coil.....	17	8-7 Inspecting piston and piston ring	60
3-5 Inspecting ignition switch	18	8-8 Replacing oil seal.....	61
3-6 Replacing ignition switch	18	8-9 Inspecting crankcase and crankshaft	62
3-7 Replacing ignition coil	20	8-10 Replacing oil seal and ball bearing.....	63
3-8 Setting pole shoe air gaps	21	8-11 Assembling crankshaft and crankcase	64
3-9 Inspecting flywheel and key.....	21	8-12 Installing piston ring and cylinder	65
4 FUEL SYSTEM	23	9 HANDLE AND CONTROL SYSTEM	66
4-1 Inspecting air filter.....	24	9-1 Replacing throttle control parts	67
4-2 Replacing air cleaner cover latch.....	25	9-2 Replacing front handle and spring	68
4-3 Inspecting fuel cap and fuel strainer	25	9-3 Replacing rear handle and springs	69
4-5 Inspecting and replacing tank vent	27	10 GUIDE BAR MOUNTING SYSTEM	71
4-6 Replacing purge bulb.....	29	10-1 Replacing nut for fixing guide bar.....	71
4-7 Replacing fuel line and fuel return line.....	30	10-2 Replacing chain tensioner	72
4-8 Adjusting carburetor	32	10-3 Replacing guide bar stud.....	73
4-8-1 General adjusting rules	32	11 MAINTENANCE GUIDE.....	74
4-8-2 Initial setting Throttle adjust screw, L mixture needle and H mixture needle.....	32	11-1 Troubleshooting guide	74
4-8-3 Adjusting carburetor	33	11-2 Disassembly chart	76
4-9 Testing carburetor	34	11-3 Service intervals	77
4-10 Inspecting crankcase pulse passage	35		
4-11 Inspecting metering lever height.....	35		
4-12 Inspecting inlet needle valve	36		
4-13 Inspecting diaphragm and others.....	37		
4-14 Replacing welch plug	37		
4-15 Installing carburetor.....	38		
5 CLUTCH SYSTEM	39		
5-1 Inspecting clutch parts	39		
5-2 Replacing clutch parts	41		
5-3 Installing clutch assembly	41		

1 SERVICE INFORMATION

1-1 Specifications

Dimensions	Length*	mm(in)	400 (15.7)
	Width	mm(in)	213 (8.4)
	Height	mm(in)	210 (8.3)
Dry weight*		kg(lb)	2.6 (5.7)
Engine	Type		YAMABIKO, air-cooled, two-stroke, single cylinder
	Rotation		Clockwise as viewed from the output end
	Displacement	cm ³ (in ³)	25.0 (1.525)
	Bore	mm(in)	35.0 (1.378)
	Stroke	mm(in)	26.0 (1.024)
	Compression ratio		7.9
Carburetor	Type		Diaphragm horizontal-draft
	Model		Walbro WT-1230
	Venturi size-Throttle bore	mm(in)	11.11 - 14.3 (0.437 - 0.563)
Ignition	Type		CDI system, Digital magneto with PI (Proportional integral) Controller
	Spark plug		NGK CMR7H-10
Exhaust	Muffler type		Spark arrester muffler with catalyst
Starter	Type		ES (Effortless-Start) / S (Soft-start)
	Rope diameter x length	mm(in)	3.0 x 720 (0.12 x 28.3)
Fuel	Type**		Mixed two-stroke fuel
	Mixture ratio		50 : 1 (2 %)
	Gasoline		Minimum 89 octane petrol
	Two-stroke air cooled engine oil		ISO-L-EGD (ISO/CD13738), JASO FC/FD
	Tank capacity	L (UK.fl.oz.)	0.19 (6.4)
Clutch	Type		Centrifugal type, 3-shoe slide with 3-tension spring
Guide bar / Saw chain lubrication type			Adjustable automatic oil pump
Oil	Tank capacity	L (UK.fl.oz.)	0.14 (4.7)
Auto oiler	Type		Clutch driven type
Sprocket	Type		Spur

CDI: Capacitor discharge ignition

* Without guide bar and saw chain.

** Premixed alkylate fuel for 2-stroke can be used.

1-1 Specifications (continued)

Cutting devices			Sprocket nose bar		
Guide bar	Type		C20S91-35SA	C25S91-40SL	C30S91-47ML
	Called length	cm	20	25	30
	Gauge	in	0.050		
Saw chain	Type		Carlton N1C-BL, OREGON 91PX		
	Number of drive links		35	40	47
	Pitch	in	3/8		
	Gauge	in	0.050		
Sprocket	Number of teeth		6		
	Pitch	in	3/8		

Cutting devices			Carving bar			
Guide bar	Type		C20SA4-52CL	C20HA4-52CL	C25SA4-60CL	C25HA4-60CL
	Called length	cm	20		25	
	Gauge	in	0.043			
Saw chain	Type		SUGIHARA A4S			
	Number of drive links		52		60	
	Pitch	in	1/4			
	Gauge	in	0.043			
Sprocket	Number of teeth		8			
	Pitch	in	1/4			

1-2 Technical data

Engine			
Compression pressure	MPa (kgf/cm ²) (psi)		1.03 (10.5) (150)
Clutch engagement speed	r/min		4,400
Ignition system			
Spark plug gap	mm(in)		0.6 - 0.7 (0.024 - 0.028)
Spark test	Tester gap w/ spark plug	mm(in)	4.0 (0.16)
	Tester gap w/o spark plug	mm(in)	6.0 (0.24)
Secondary coil resistance	Ω		960 - 1,000
Pole shoe air gaps	mm (in)		0.3 - 0.4 (0.012 - 0.016)
Ignition timing	at 1,000 r/min	°BTDC	9
	at 3,000 r/min	°BTDC	9
	at 10,000 r/min	°BTDC	30
Carburetor			
Test Pressure, minimum	MPa (kgf/cm ²) (psi)		0.05 (0.5) (7.0)
Metering lever height	mm(in)		1.65 (0.06) lower than diaphragm seat
Tool to adjust mixture needles			D-shaped tool (L) P/N X645-000031
Chain oil discharge volume	mL/min (UK.fl.oz./min)		Adjustable: 1.5 - 13 (0.05 - 0.46) (Factory set: 6 mL/min)

BTDC: Before top dead center

1-2 Technical data (continued)

Carburetor adjustment			Mixed two-stroke regular fuel	Mixed two-stroke E10 fuel	Premixed alkylate fuel
Fuel type					
1) Initial setting	H mixture needle	turn out	1 3/4	2	2 1/4
	L mixture needle	turn out	2 1/2		
	Throttle adjust screw	turn in* ¹	1 1/2		

*¹ Set Throttle adjust screw to the point that its tip just contacts throttle plate before initial setting.

IMPORTANT: Use Tachometer PET-1000R to measure engine speed (Refer to 1-6 Special tools).

IMPORTANT: The PI controller installed model has 2 mode; Carburetor adjustment mode and Operation mode. When adjusting carburetor, must be changed from Operation mode to Carburetor adjustment mode. The mode will return to the Operation mode when the engine is stopped.

To change the mode,

1. **Start engine without brake activated.** (Do not touch throttle lever.)
2. **Engine warm-up with fast idle for 120 seconds.** (The speed should be within 6,000 - 10,000 r/min. If it is not, adjust the speed by turning H mixture needle.)

CAUTION: Chain will start to rotate during engine warm-up with fast idle.

NOTE: Do not stop engine during carburetor adjustment. If the engine is stopped, restart this procedure from the beginning.

The carburetor adjustment continues.

Engine warm-up	Idle - WOT : Total	sec.	5 - 5 : 30
2) Confirm that the mode has changed	Confirm to vary the idle engine speed by turning L mixture needle 1/4 turn CW. If the speed does not vary, change the mode again. (The idle engine speed returns to 3,200 r/min for a few seconds in Operation mode, when the engine speed is deviated.)		
3) Find idle maximum speed	Adjust L mixture needle to maximum idle speed* ²		
4) Set idle maximum speed w/ TAS	r/min	4,100	
5) Set idle speed by turning L mixture needle CCW	r/min	3,300	
6) Verify final engine speed with standard equipment	r/min	Idle: 3,100 - 3,300 WOT: 12,800 - 13,400 If the WOT speed is not within above range, readjust H mixture needle and reverify the speed. If that does not work, adjust H mixture needle by 1/8 turn and reverify the speed.	
7) Verify clutch engagement speed	Confirm clutch engagement speed. If it is less than 1.25 times the idle speed, adjust the idle speed by turning TAS CCW.		

WOT: Wide open throttle **CCW:** Counterclockwise **TAS:** Throttle adjust screw

*² If clutch engages during adjustment process 2), decrease engine speed by turning TAS CCW until clutch disengages and then redo 2).

1-3 Torque limits

Descriptions		Size	kgf•cm	N•m	in•lbf	
Starter system	Starter pawl	M5	30 - 45	3 - 4.5	25 - 40	
	Starter case	M4	20 - 30	2 - 3	20 - 25	
Ignition system	Magneto rotor (Flywheel)	M8	250 - 290	25 - 29	220 - 255	
	Ignition coil	M4*	30 - 45	3 - 4.5	25 - 40	
	Ignition switch	M3*	3 - 5	0.3 - 0.5	3 - 4	
	Spark plug	M10	100 - 150	10 - 15	90 - 135	
Fuel system	Carburetor	M5	30 - 45	3 - 4.5	26 - 40	
	Intake bellows	M4	30 - 45	3 - 4.5	26 - 40	
Clutch	Clutch hub	LM8	250 - 290	25 - 29	220 - 255	
Engine	Crankcase	M4	30 - 45	3 - 4.5	26 - 40	
	Cylinder	M4	30 - 45	3 - 4.5	26 - 40	
	Engine mount	M4	35 - 50	3.5 - 5	30 - 45	
	Muffler	M5	60 - 90	6 - 9	52 - 80	
	Muffler cover	M4 [†]	20 - 30	2 - 3	20 - 25	
Others	Auto-oiler	M4	30 - 45	3 - 4.5	26 - 40	
	Front handle	Clutch side	M5	30 - 40	3 - 4	26 - 35
		Recoil side	M4 [†]	25 - 30	2.5 - 3	18 - 26
	Compression spring	M4 [†]	20 - 35	2 - 3.5	20 - 30	
	Brake cover	M4 [†]	20 - 30	2 - 3	20 - 25	
	Sprocket guard plate (Sprocket guard side)	M4 [†]	20 - 30	2 - 3	20 - 25	
	Brake lever (Hand guard)	M5	30 - 45	3 - 4.5	26 - 40	
	Chain catcher	M5	30 - 45	3 - 4.5	26 - 40	
	Stud bolt	M8 [*]	150 - 200	15 - 20	130 - 220	
	Bolt (at guide bar mount)	M5	30 - 45	3 - 4.5	26 - 40	
	Guide bar nut	M8	120 - 150	12 - 15	105 - 135	
	Spike	M5 [†]	30 - 45	3 - 4.5	26 - 40	
	Regular bolt, nut and screw		M3	6 - 10	0.6 - 1	5 - 9
		M4	15 - 25	1.5 - 2.5	13 - 22	
		M5	25 - 45	2.5 - 4.5	22 - 40	

LM: Left-hand thread * Apply thread locking sealant. (See below)

[†] Tapping screw

1-4 Special repairing materials

Material	Location	Remarks
Thread locking sealant	Stud bolt	Loctite #242, ThreeBond #1324 or equivalent
	Ignition coil	Loctite #222, ThreeBond #1342 or equivalent
	Ignition switch	Loctite #242, ThreeBond #1324 or equivalent
Grease	Recoil starter	EPNOC AP2 (Lithium based grease) P/N X695-000060
	Needle bearing, clutch	
	Worm gear	
	Oil seal lip	
	Chain brake (metal contact part)	Molybdenum grease (approx.1 gram)

1-5 Service limits

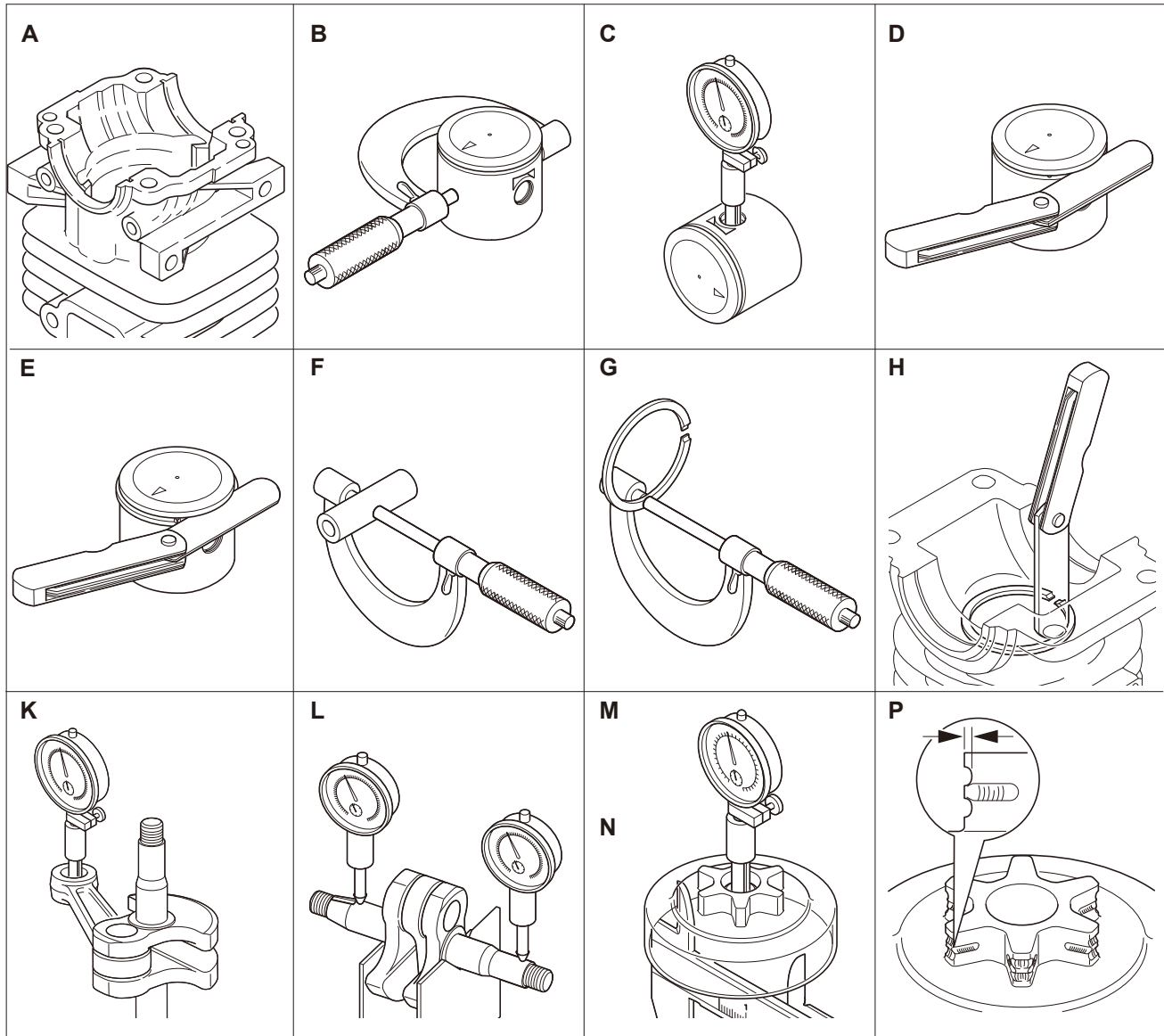

Description		mm (in)	
A	Cylinder bore	When plating is worn and aluminium can be seen	
B	Piston outer diameter	Min.	34.92 (1.375)
C	Piston pin bore	Max.	8.035 (0.3163)
D	Piston ring groove	Max.	1.3 (0.051)
E	Piston ring side clearance	Max.	0.1 (0.004)
F	Piston pin outer diameter	Min.	7.98 (0.3142)
G	Piston ring width	Min.	1.15 (0.045)
H	Piston ring end gap	Max.	0.5 (0.02)
K	Con-rod small end bore	Max.	11.03 (0.4341)
L	Crankshaft runout	Max.	0.02 (0.001)
M	Sprocket bore	Max.	13.07 (0.5146)
N	Clutch drum bore	Max.	53.5 (2.11)
P	Sprocket wear limit	Max.	0.5 (0.02)

1-6 Special tools

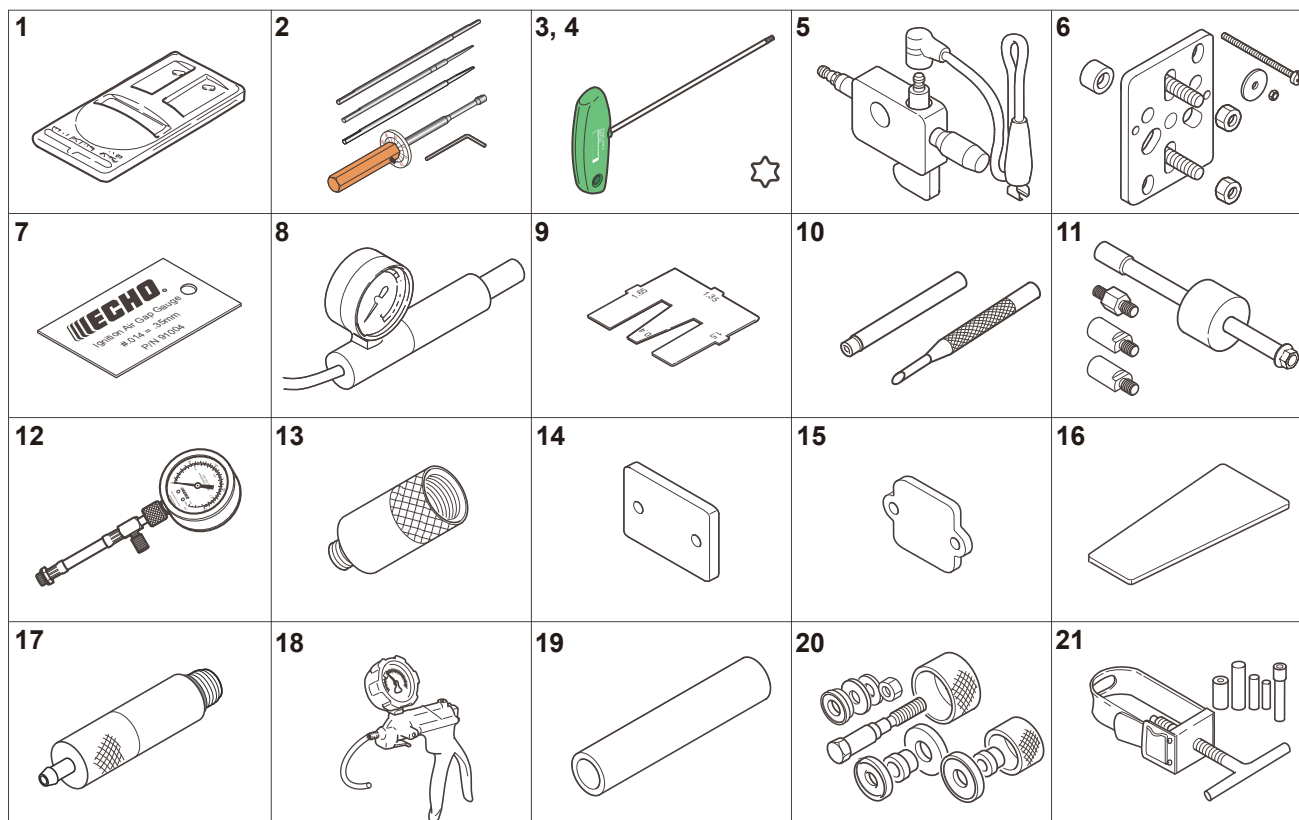

Key	Part Number	Description	Reference
1	897802-33330	Tachometer PET-1000R	Measuring engine speed to adjust Carburetor
2	Y089-000095	Carburetor Adjustment tool	Adjusting Carburetor
3	X602-000330	Torx wrench (T25)	Removing and installing Torx bolt
4	X602-000340	Torx wrench (T27)	Removing and installing Torx bolt
5	897800-79931	Spark tester	Checking ignition system
6	Y089-000111	Puller	Removing magneto rotor and crankcase
7	91004	Module air gap gauge	Adjusting pole shoe air gaps
8	897803-30133	Pressure tester	Testing Carburetor and crankcase leakage
9	897563-19830	Metering lever gauge	Measuring metering lever height on Carburetor
10	500-500	Welch plug tool	Removing and installing welch plug
11	P021-044870	PTO shaft puller	Removing plug from auto-oiler assembly
12	91037	Compression gauge	Measuring cylinder compression
13	P021-051690	Adapter (M10)	Measuring cylinder compression(for 10mm dia. spark plug)
14	897826-16131	Pressure rubber plug	Plugging intake port to test crankcase / cylinder leakages
15	897827-16131	Pressure plate	Plugging intake port to test crankcase / cylinder leakages
16	91041	Pressure rubber plug	Plugging exhaust port to test crankcase / cylinder leakages
17	A131-000160	Pressure connector(M10)	Checking crankcase and cylinder leakages
18	91149	Pressure / vacuum tester	Testing tank vent and crankcase leakages
19	897726-09130	Oil seal tool	Installing oil seals
20	897701-14732	Bearing tool	Removing and installing ball bearings on crankcase
21	897702-30131	Piston pin tool	Removing and installing piston pin

2 STARTER SYSTEM (ES-start / S-start)

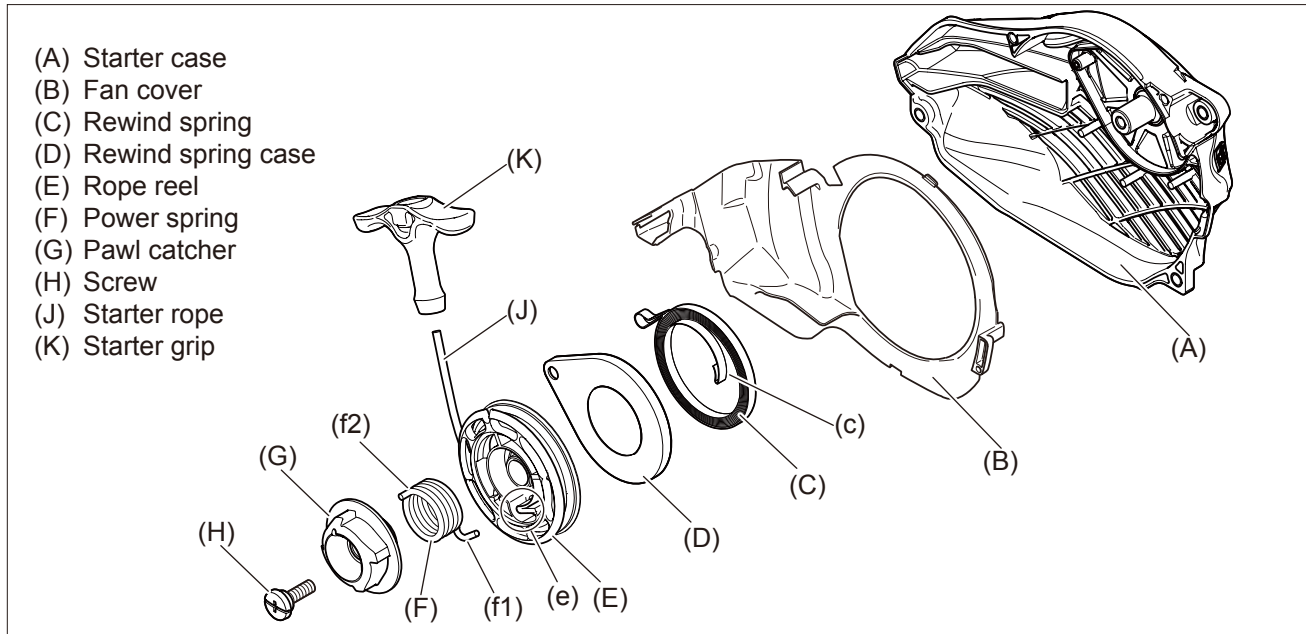
**Construction**

1. Rewind spring (C) and rewind spring case (D) are installed inside starter case (A).
2. Rope reel (E) with starter rope (J) is installed on rewind spring case assembly.
3. Hook located on the backside of rope reel engages with end (c) of rewind spring (C).
4. Power spring (F) is installed on rope reel (E).
5. Hook (f1) of power spring (F) engages with hook (e) of rope reel (E) and top end hook (f2) of power spring (F) engages with pawl catcher (G).

Working principle

1. When starter grip (K) is pulled, rope reel (E) rotates.
2. The rotation force of rope reel (E) is transmitted to pawl catcher (G) by power spring (F).
3. Pawl catcher (G) engages with starter pawls on flywheel to turn crankshaft.
4. The load from compression pressure in cylinder will keep crankshaft from rotating as power spring (F) is twisted and accumulates energy.
5. As starter grip (K) is pulled further, more energy is stored in power spring (F) until accumulated energy is enough to overcome compression pressure in cylinder.
6. When accumulated energy in power spring (F) overcomes the load from compression pressure in cylinder, crankshaft is rotated.
7. Power spring (F) absorbs compression resistance of cylinder and snatch back of engine during starting action.
8. When starter rope (J) is released, rope reel (E) is returned together with power spring (F) and pawl catcher (G) by rewind spring tension.
9. After engine starts, starter pawls pivot outward by centrifugal force and disengage from pawl catcher (G).

2-1 Disassembling starter assembly

1. Remove three bolts and starter assembly (A) from the unit.
2. Remove fan cover (B) from starter assembly (A).
3. Pull out starter rope about 30cm (12in) and hold rope reel (D) by hand. Loop excess rope in rope reel notch (d) as shown.
4. Rotate rope reel (D) counterclockwise to release tension of rewind spring.
5. Remove screw (E).
6. Remove pawl catcher (F) and power spring (G).
7. Remove rope reel (D) from starter case (H) slowly to prevent rewind spring (J) from unwinding.
8. Remove rewind spring case assembly (K) from starter case (H).

WARNING **DANGER**

Wear eye protection and take care when removing rope reel. Rewind spring may unwind suddenly and cause personal injury.

2-2 Replacing starter rope

1. Pull out and untie knot (A).
2. Pull knot (B) to remove rope from rope reel (C).
3. When installing a new starter rope, singe both ends of the rope to prevent fraying.
4. Make a knot (D) at end of starter rope and pass the rope through hole of rope reel (C), then press the knot (D) into recess as shown.
5. Pass the other end of starter rope through starter case, from inside to outside.
6. Pass starter rope through starter grip (E). Make a knot as shown.
7. Tighten knot (F). Push the knot (F) into recess of starter grip (E).

2-3 Assembling starter

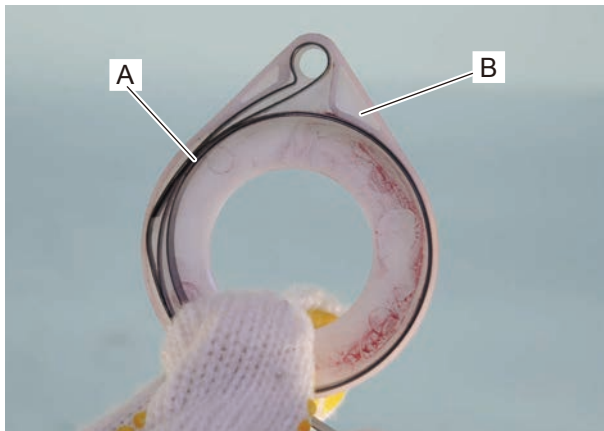

1. If rewind spring (A) is unwound from rewind spring case (B), wind the spring (A) inside case (B) as shown.

NOTE : Apply small amount of lithium based grease to rewind spring case (B), before wind the spring.

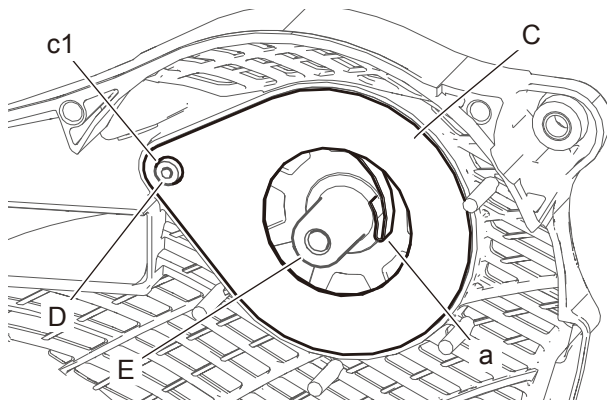

2. Carefully install rewind spring case assembly (C) on starter case, matching hole (c1) with post (D). Hook (a) of rewind spring should contact with post (E) of starter case.

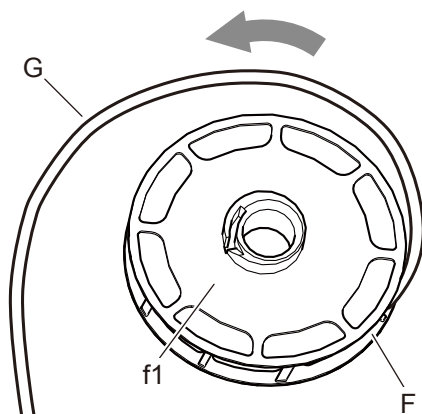

3. Wind the rope (G) on rope reel (F) 2 turns as shown.

4. Apply small amount of lithium based grease to starter case side (f1) of the rope reel (F).

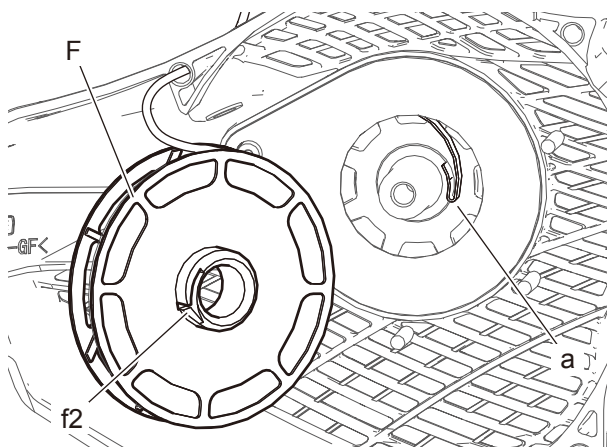

5. Assemble rope reel (F) engaging hook (f2) with hook (a) of rewind spring.

2-3 Assembling starter (Continued)

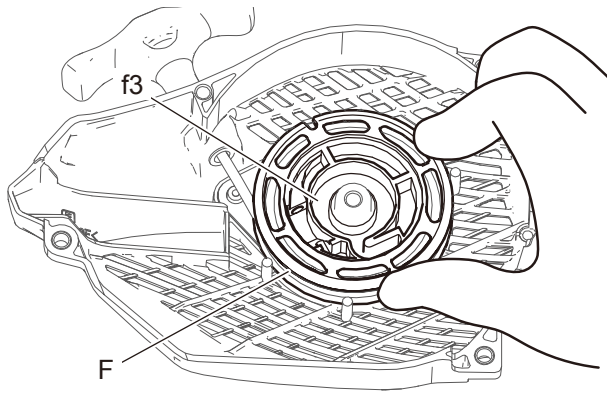

6. Check for proper engagement of rewind spring and rope reel (F) by turning rope reel (F) clockwise and counterclockwise.

7. Apply small amount of lithium based grease to power spring mounting groove (f3) of the rope reel (F).

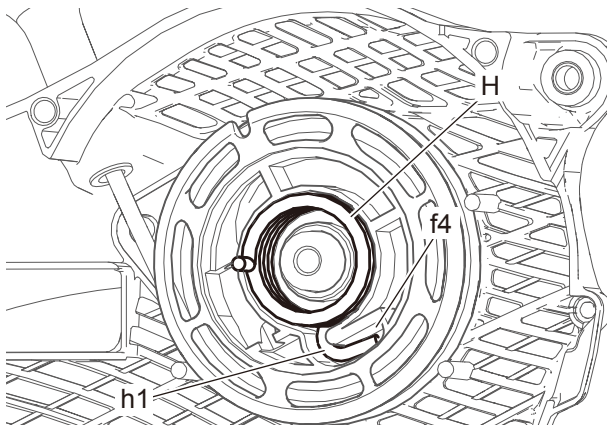

8. Install power spring (H), engaging hook (h1) with rope reel groove (f4).

9. Install pawl catcher (J), engaging hole (j) with power spring top end hook (h2).

10. Reinstall screw (K) on starter post.

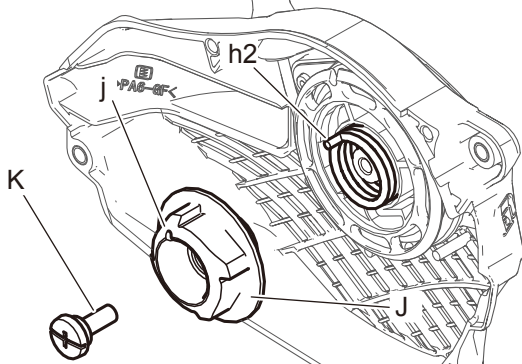

11. Pull out starter rope inside starter case. Rotate rope reel (F) clockwise 3 turns with starter rope hooked at notch (f5) as shown. Hold rope reel (F) to prevent it from unwinding and pull out starter grip to take the rope slack.

12. Pull starter several times to check rewind spring tension. If starter is not rewinding fully, increase spring tension by rotating rope reel (F) one more turn clockwise following above step 11.

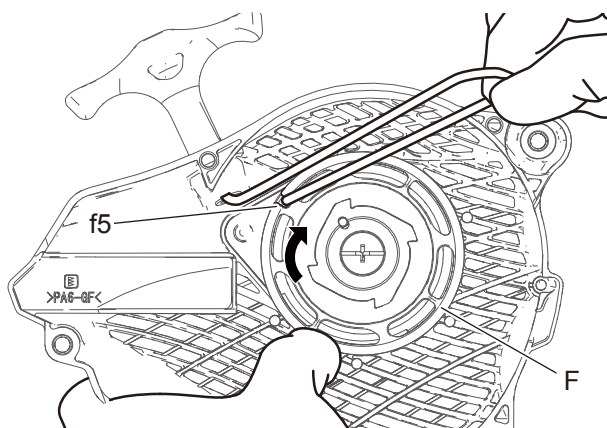

2-3 Assembling starter (continued)

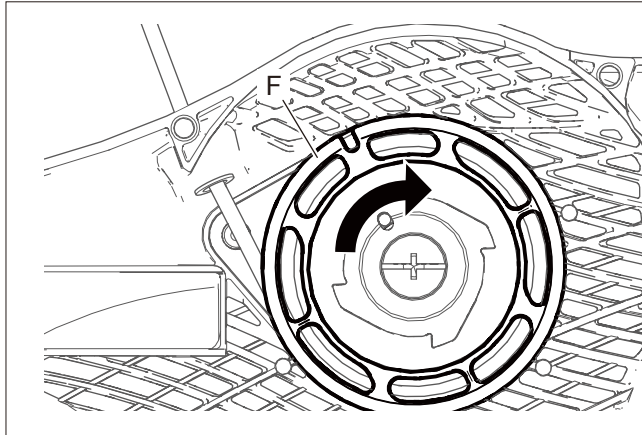

13. Pull out starter rope all the way, and check that rope reel (F) can be rotated an additional half or more turn clockwise as shown, to prevent rewind spring from breaking.

14. If rope reel (F) can not be turned clockwise, reduce tension by rotating rope reel (F) counter-clockwise one turn with starter rope hooked at notch (f5).

15. Reinstall fan cover to starter case.

16. Reassemble starter assembly to unit.

2-4 Replacing starter pawl

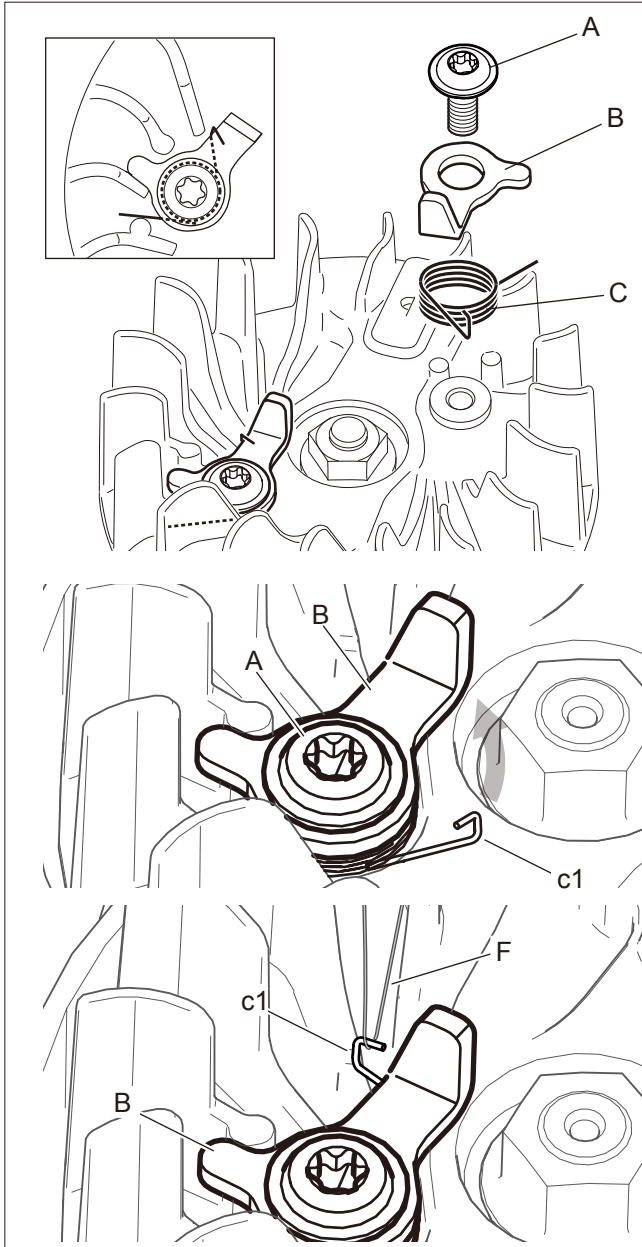

1. Remove starter assembly from unit.

2. Loosen bolt (A) and remove pawl (B) and torsion spring (C). Replace damaged or worn parts.

NOTE: When it is hard to loosen bolt, install clean rope (D) in spark plug hole (E) to stop crankshaft rotation and remove bolt easily.

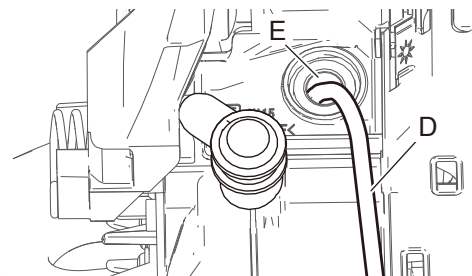

3. Install torsion spring (C), pawl (B), and bolt (A). To avoid pinching of torsion spring (C), install these parts without setting the end (c1) of torsion spring (C) on starter pawl.

4. Using fine wire (F) or appropriate tool, place the end (c1) of torsion spring (C) on pawl (B), by hooking and passing under pawl as shown.

5. Make sure pawl (B) can move smoothly. If it does not move smoothly, check parts for correct installation.

3 IGNITION SYSTEM

- (A) Ignition switch
- (B) Spark plug
- (C) Spark plug cap coil
- (D) Spark plug cap
- (E) Ignition coil
- (F) Bolt (M4)
- (G) Collar
- (H) Flywheel
- (J) Nut (M8)
- (K) Woodruff key

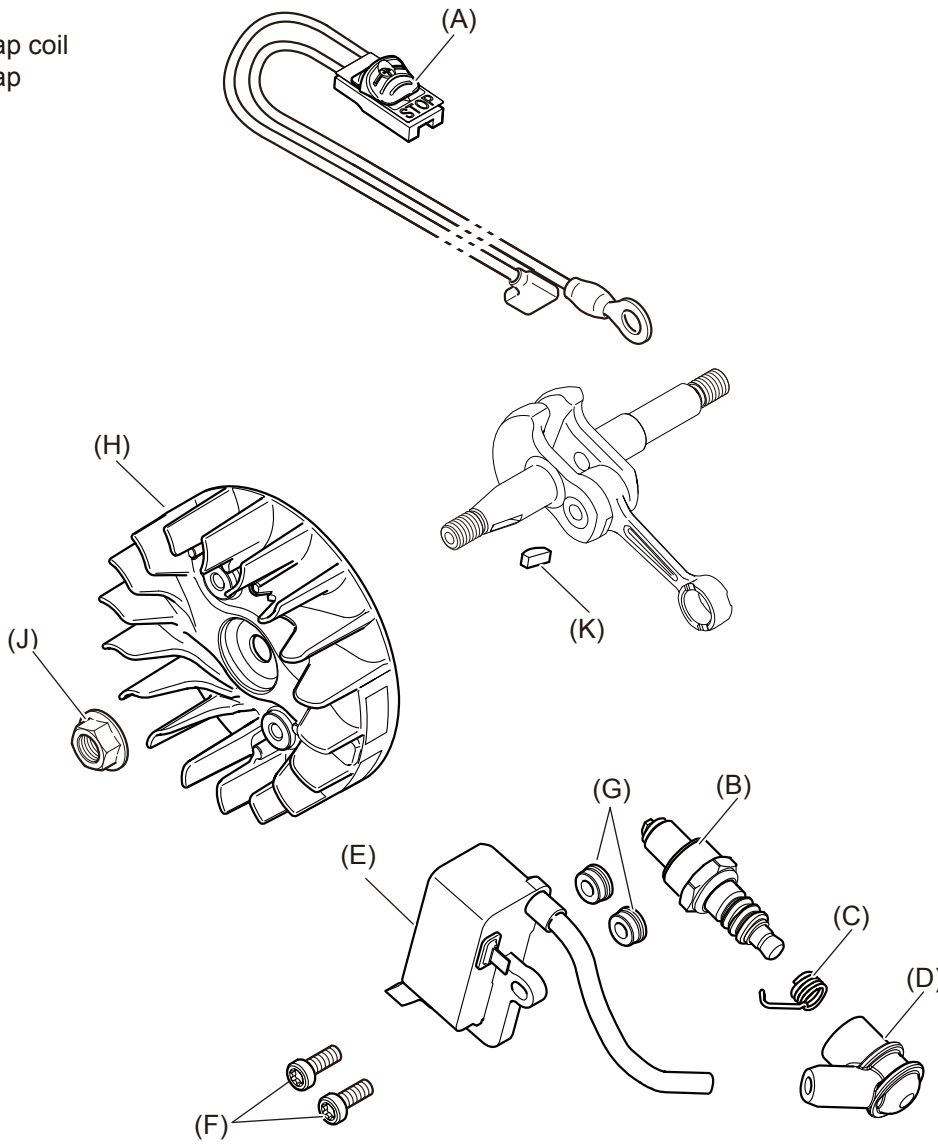

3-1 Troubleshooting guide

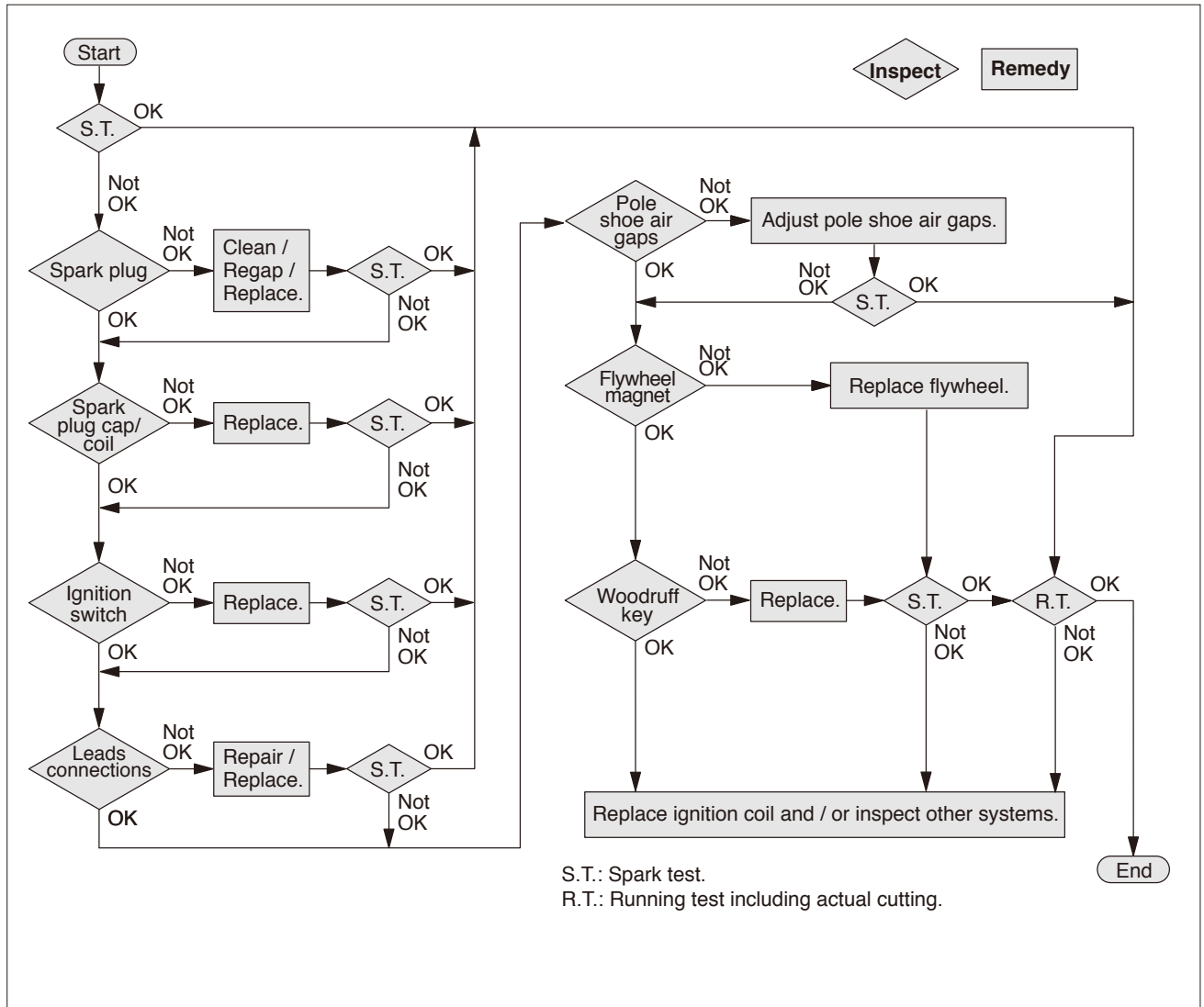

3-2 Testing spark



1. Unhook ring (A) with screwdriver (B) or equivalent and open cap cover (C).

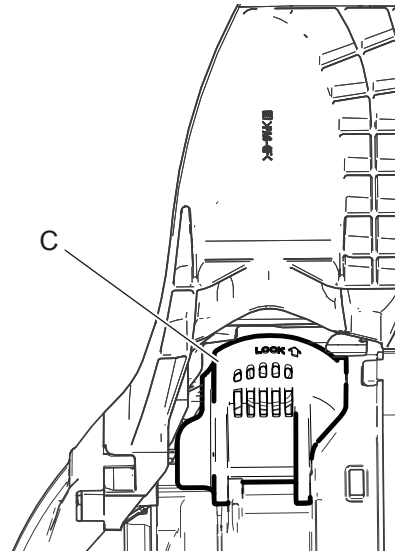

2. Remove spark plug cap (D) from spark plug (E).

3. Connect spark plug cap (D) to spark tester 897800-79931 (F), and connect spark tester lead (G) on spark plug (E) as shown.

4. Screw in adjuster (f1) until the needle tips contact. Turn out adjuster (f1) 4 turns to set spark tester gap (f2) to 4 mm (0.16 in).

5. Turn ignition switch to "RUN" position. Pull starter grip several times.

6. If spark is steady blue or white at the tester gap, ignition system is considered good.

7. If no spark exists or spark is intermittent in yellow, orange, or red, continue with further inspection.

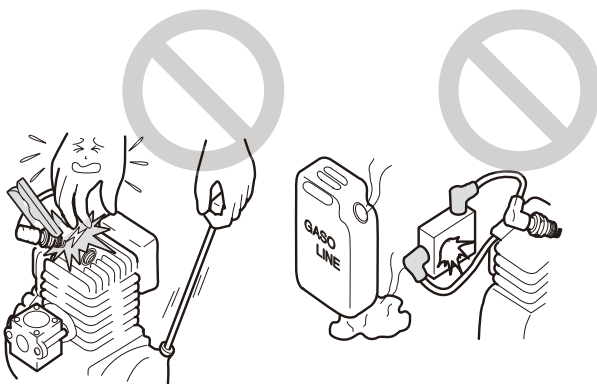
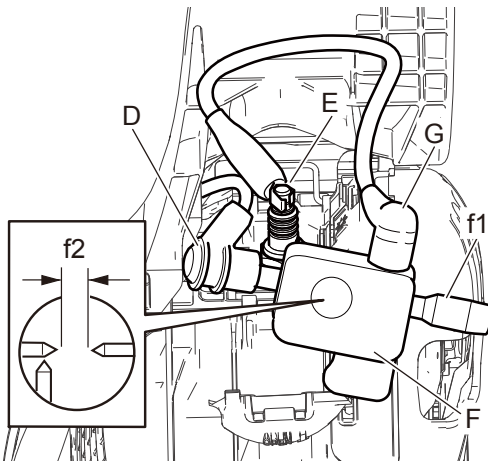
**WARNING ! DANGER**

*Do not test near spark plug hole without spark plug installed, otherwise there is a chance to ignite fuel mixture inside cylinder.

*Do not touch metal parts of spark tester while performing the test to avoid receiving electrical shock.

*Do not check spark in area where gasoline is spilled or flammable gases may exist.

3-3 Inspecting spark plug

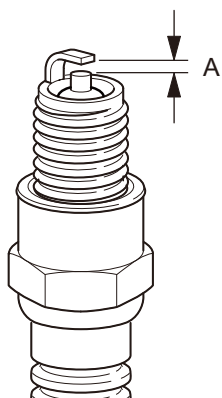

1. Remove spark plug from the unit.
2. Inspect for spark plug gap fouling, cracked or broken insulator, cracked outer electrode, or rounded center electrode. Replace spark plug as required.

Spark plug gap (A) Standard :

0.9 to 1.0 mm (0.035 to 0.039 in)

3. If engine does not start with correct spark plug, inspect if spark plug is wet or dry. If it is excessively wet or dry, inspect fuel system.

3-4 Replacing spark plug cap and coil

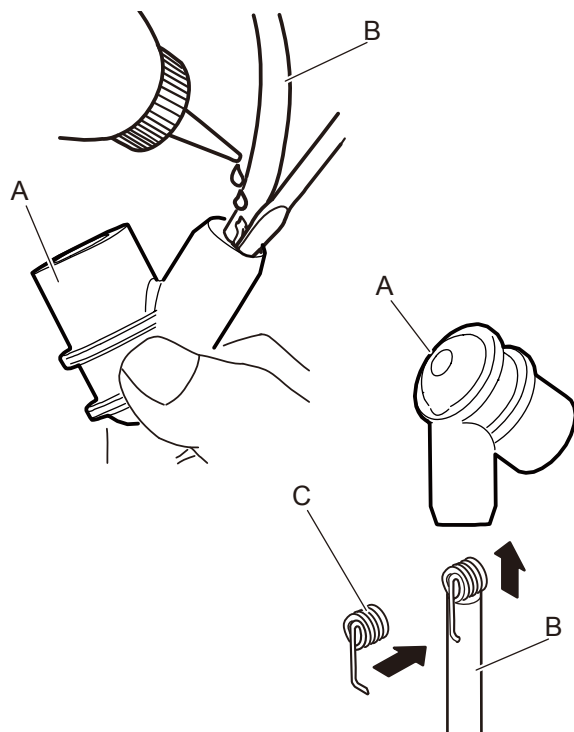

1. Disconnect spark plug cap (A) from spark plug.
2. Apply some oil in spark plug cap (A) for easy removal from high tension lead (B).
3. Pull spark plug cap away from high tension lead.
4. Inspect spark plug cap coil (C) for corrosion and correct connection. Inspect spark plug cap for cracks. Replace as required.

NOTE: Make sure spark plug cap coil (C) contacts center core of high tension lead when reinstalling.

5. Coat the end of high tension lead (B) with small amount of oil, and insert into spark plug cap (A) as shown, until the spark plug cap coil is properly seated in the cap.

3-5 Inspecting ignition switch

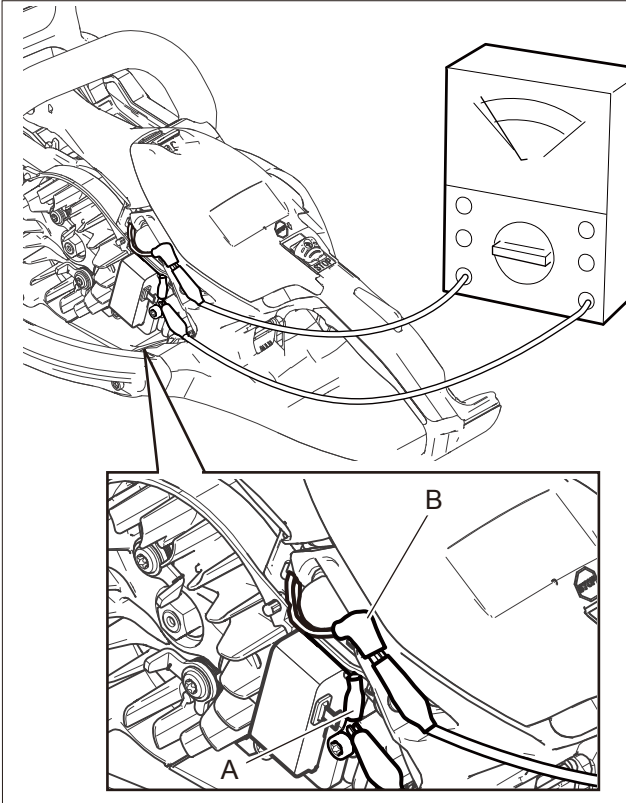

1. Remove starter assembly.
2. Connect one probe of ohm-meter or multi-meter to ignition switch terminal (A). Connect the other probe to another ignition switch terminal (B).
3. When ignition switch is "RUN" position, tester should indicate infinite resistance.
4. When ignition switch is in "STOP" position, tester should show that the circuit is in conducting state (closed circuit).
5. If ignition switch is defective, replace with new one.

3-6 Replacing ignition switch

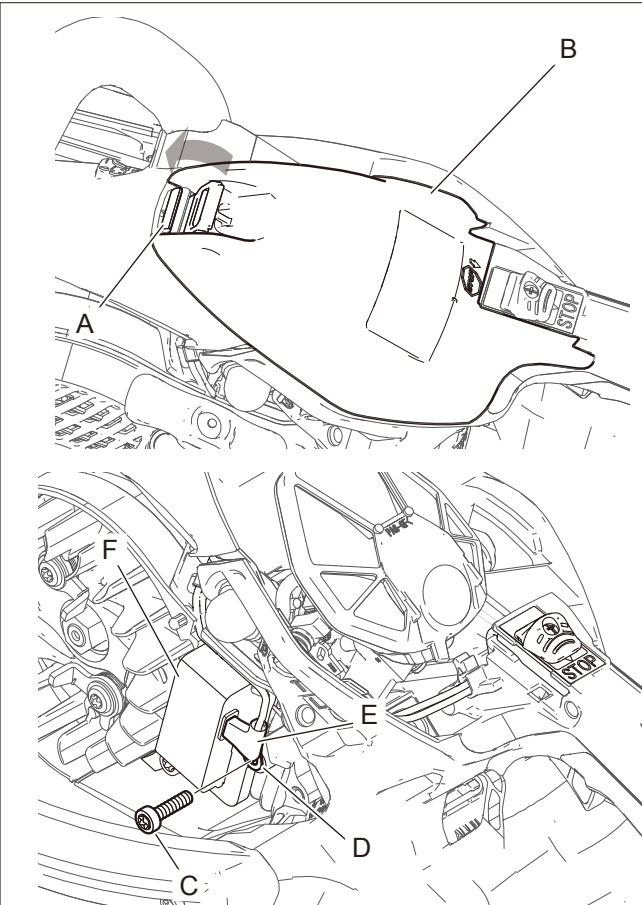
**{Removing}**

1. Remove starter assembly.
2. Unlock air cleaner cover latch (A) and remove air cleaner cover (B) from the unit.
3. Remove bolt (C), ignition switch terminal (D) and (E) from ignition coil (F).

3-6 Replacing ignition switch (Continued)

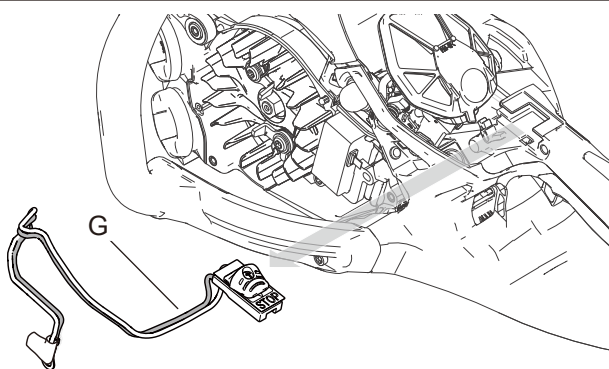

4. Remove ignition switch (G) from the unit as shown.

{Installing}

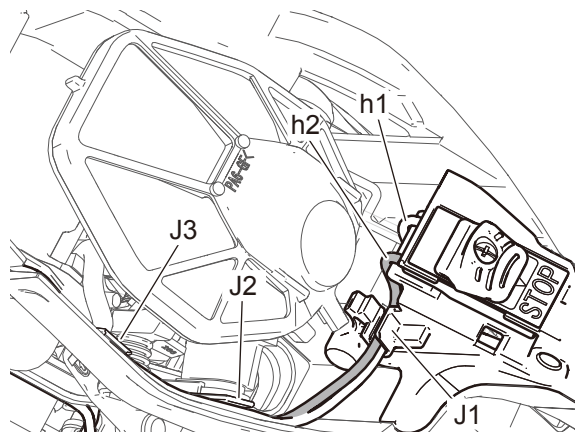

5. Install new ignition switch.

6. Pass switch lead (h1) through rib (J1) and then pass switch lead (h2) over the lead (h1) as shown.

7. Pass switch leads (h1) and (h2) through ribs (j2) and (j3) as shown.

NOTE: Do not hide TAS hole (L) by the leads (h1) and (h2) as shown.

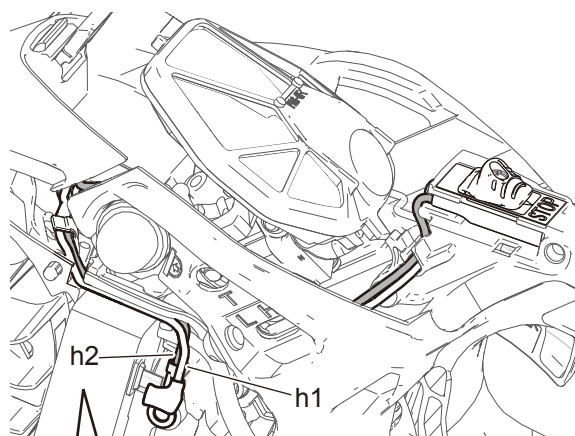
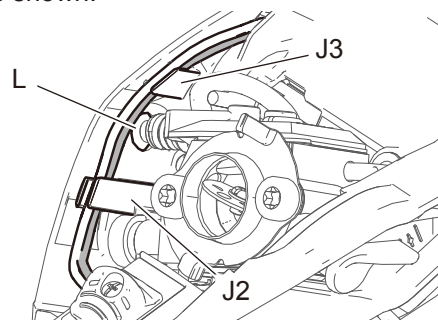

8. Pass switch leads (h1) and (h2) through rib (J4) and notch (K) as shown.

9. Install switch terminal (E) on ignition coil (F) and bolt (C) with switch terminal (D). (Refer to **3-7 Replacing ignition coil** and **3-8 Setting pole shoe air gaps**).

10. Reassemble removed parts.

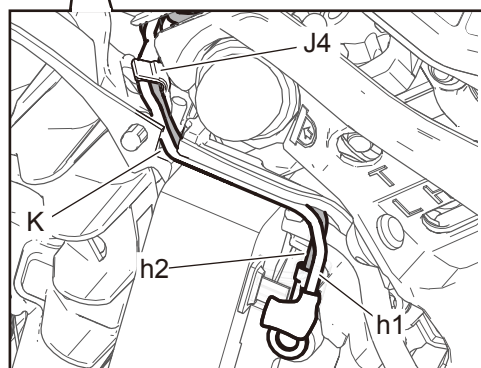

3-7 Replacing ignition coil

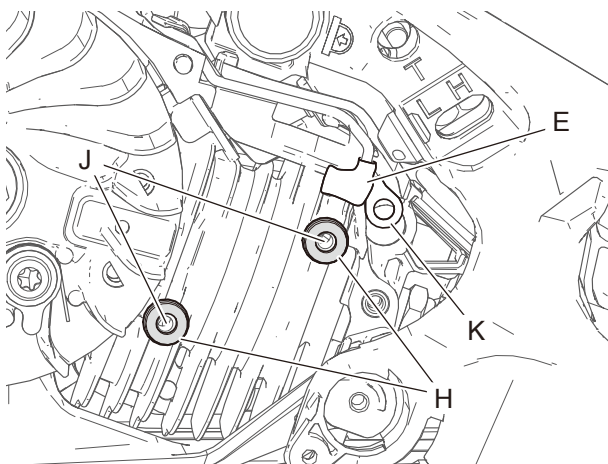
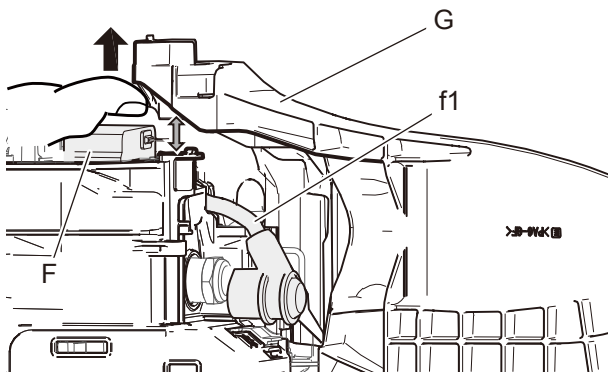
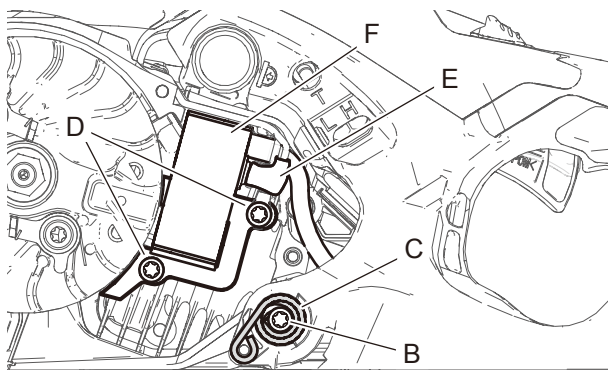
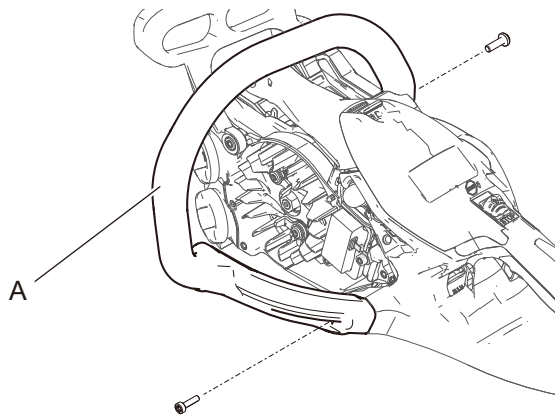

1. Remove starter assembly.
2. Disconnect spark plug cap from spark plug.
3. Remove front handle (A) with two bolts (Refer to **9-2 Replacing front handle and spring**).

4. Remove bolt (B) and spring (C).
5. Remove two bolts (D). Disconnect ignition switch terminal (E) from ignition coil (F).

6. Push up rear handle (G) to take out hightension lead (f1) as shown.

7. Remove ignition coil (F), taking care not to lose collars.

8. Remove spark plug cap, spark plug cap coil from high tension lead. (Refer to **3-4 Replacing spark plug cap and coil**).

9. Install spark plug cap and spark plug cap coil to new ignition coil.

10. Apply a drop of thread locking sealant (Loctite#222 or ThreeBond #1344J or equivalent) to tapped hole (J) of cylinder.

9. Set collars (H), facing flange side to the cylinder.



10. Loosely install new ignition coil and ignition switch terminal (K) with two bolts (D). Set pole shoe air gaps (Refer to **3-8 Setting pole shoe air gaps**). Tighten two bolts (D).

11. Connect ignition switch terminal (E) to ignition coil.

12. Reassemble all removed parts.

3-8 Setting pole shoe air gaps

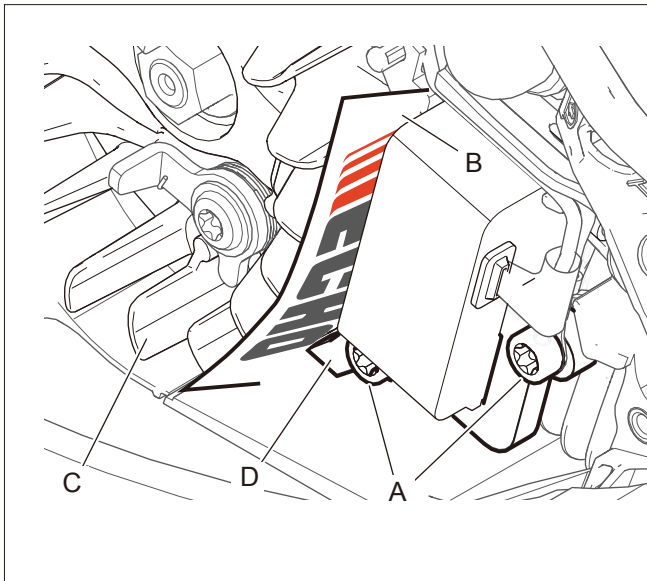

1. Loosen two bolts (A) and insert Module air gap gauge: 91004 (B) or 0.3 - 0.4 mm (0.012 - 0.016 in) thick feeler gauge between flywheel (C) and ignition coil shoes (D).

2. Rotate flywheel (C) until magnetic poles of flywheel face ignition coil shoes (D).

3. Hold ignition coil against flywheel (C) and tighten the bolts (A) (Refer to **3-7 Replacing ignition coil**). After tightening bolts, remove Module air gap gauge: 91004 (B) or feeler gauge.

NOTE: When the air gap is too narrow, contact with flywheel may result. When the air gap is too wide, spark is weak.

4. Reassemble all removed parts.

3-9 Inspecting flywheel and key

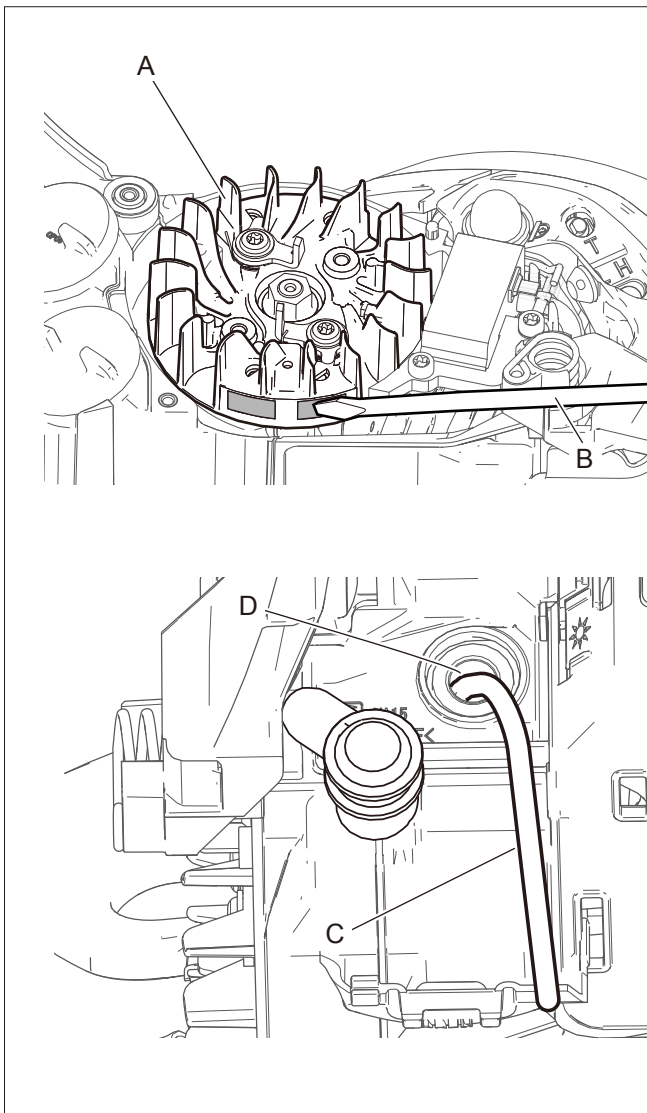

1. Inspect magnetic force of flywheel (A) using flux meter, or screwdriver (B) as shown.

2. If magnetic force is weak, replace flywheel (A) as follows.

3. Disconnect spark plug cap and remove spark plug.

4. Install clean rope (C) in spark plug hole (D) to stop crankshaft rotation.

NOTE: Do not use piston stopper to avoid piston damage.

3-9 Inspecting flywheel and woodruff key (Continued)

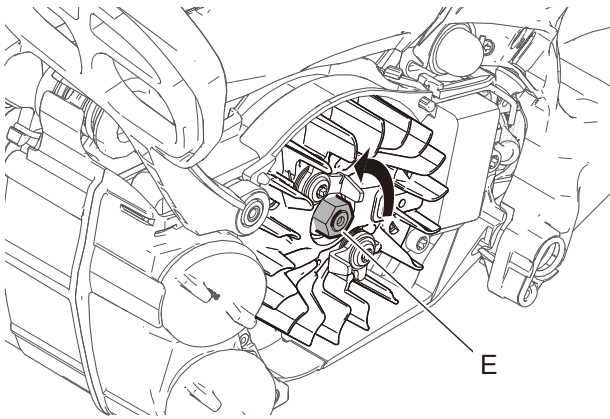

5. Remove nut (E) by rotating counterclockwise.

NOTE: Do not use power tool to remove nut (E). Otherwise, piston damage may occur.

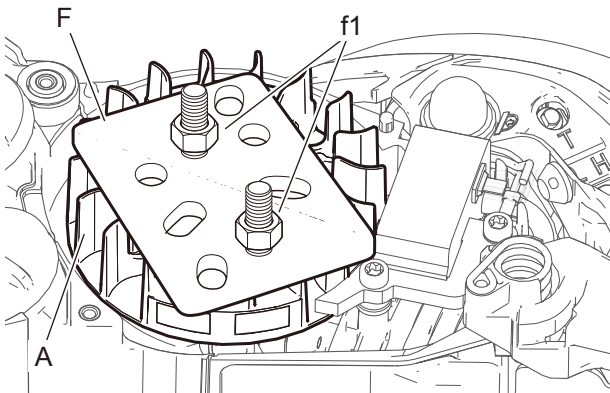

6. Remove starter pawls. Then set puller Y089-000111 (F) on flywheel (A) as shown.

7. Tighten two nuts (f1) on the puller alternately to remove flywheel (A).

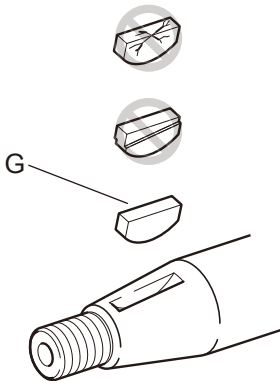

8. Inspect woodruff key (G) for damage or shearing. Replace as required.

9. Wipe off oil from taper part of crankshaft and flywheel before assembling flywheel.

10. Install woodruff key (G) into key groove.

11. Align the woodruff key with center line of crankshaft. Install flywheel and fasten flywheel nut clockwise.

12. Reinstall starter pawls (Refer to **2-4 Replacing starter pawl**).

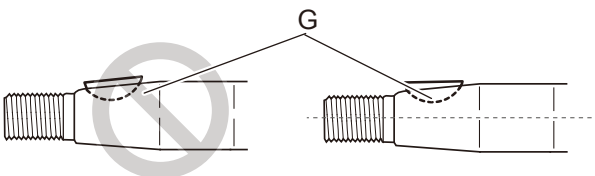

4 FUEL SYSTEM

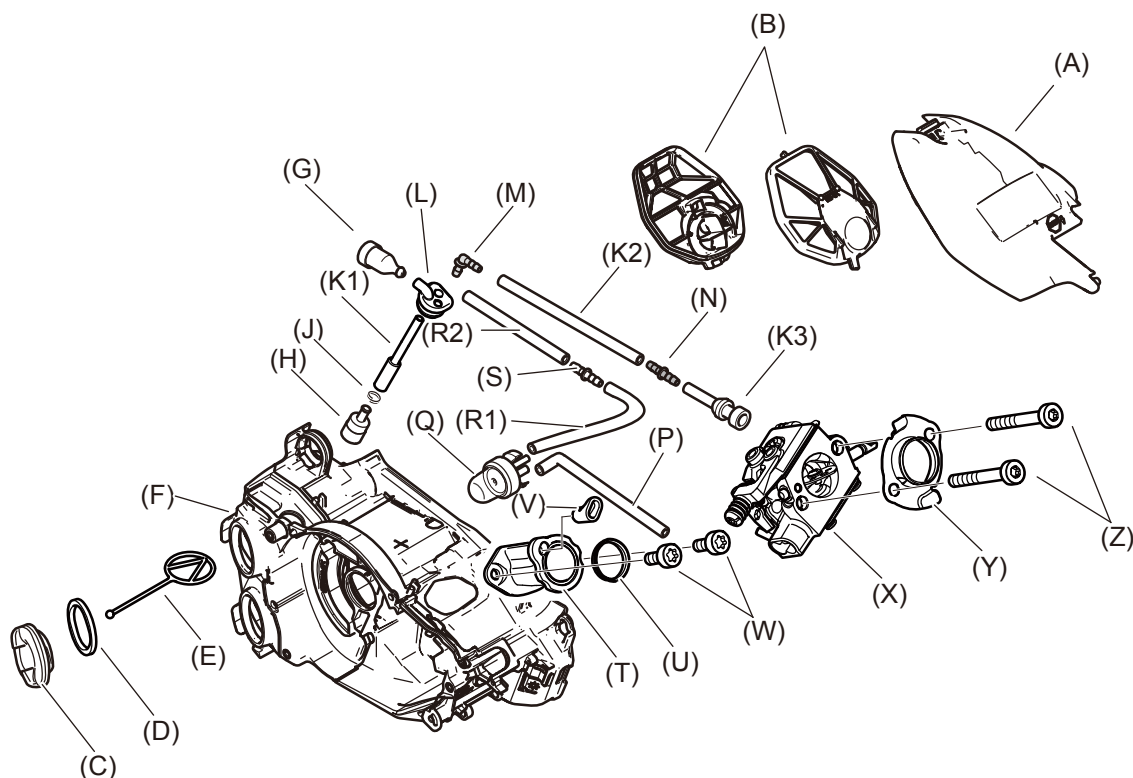

- | | |
|-------------------------------|-----------------------------------|
| (A) Air cleaner cover | (N) Joint (black) |
| (B) Air filter | (P) Purge line (L-shaped) |
| (C) Fuel cap | (Q) Purge bulb |
| (D) Gasket | (R1) Fuel return line (3x5x58mm) |
| (E) Connector | (R2) Fuel return line (3x5x115mm) |
| (F) Fuel tank | (S) Joint (white) |
| (G) Fuel tank vent | (T) Intake bellows |
| (H) Fuel strainer | (U) Collar |
| (J) Clip | (V) Collar |
| (K1) Fuel line (in fuel tank) | (W) Bolt (M4) |
| (K2) Fuel line (3x5x95mm) | (X) Carburetor |
| (K3) Fuel line | (Y) Carburetor elbow |
| (L) Grommet | (Z) Bolt (M5) |
| (M) Joint (L-shaped, black) | |

4-1 Inspecting air filter

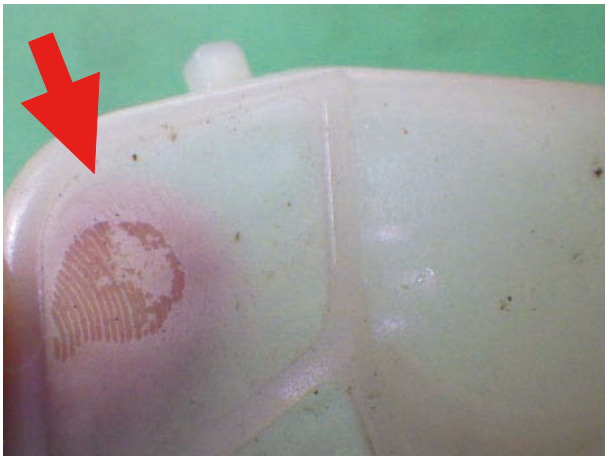
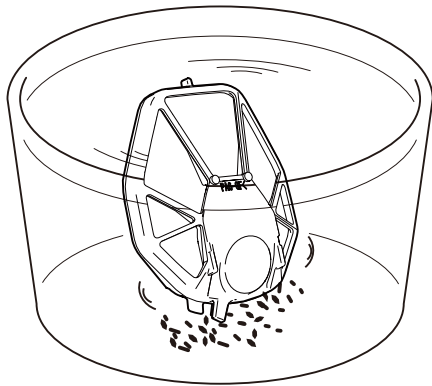
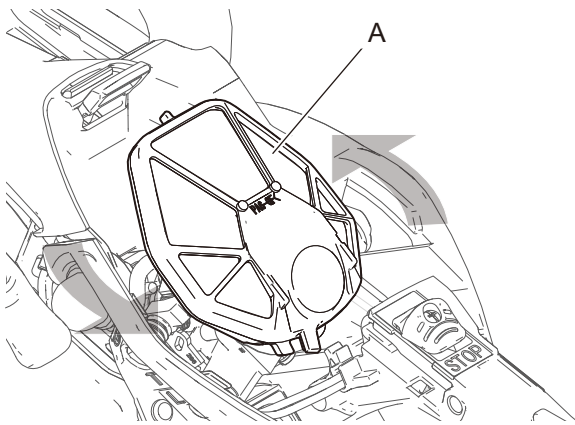

1. Close choke shutter. Remove air cleaner cover.
2. Remove air filter (A), twisting as shown in the picture.
3. Inspect the air filter. If blocked with dirt or dust, remove the obstruction using brush.

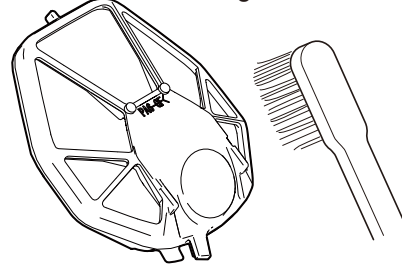

4. If heavily blocked with dirt or dust, clean the air filter with compressed air or wash away with non-flammable solvent/detergent.

WARNING  **DANGER**

Wear eye protection when working with compressed air. Eye damage can occur from flying particles.

8. If a large amount of oil sticks on air filter, wash away oil with non-flammable solvent/detergent.

NOTE: Finding oil on air filter mesh

Oil on air filter mesh may close texture hole. By that air coming into engine can be blocked.

To find such oil take the following.

- a) Disassemble air filter assembly.
- b) Touch air filter mesh by finger tip from opposite side.
- c) If your fingerprint is clearly shown as picture, it is a clue that much oil is on the mesh.

9. If dirt/dust or oil is not cleaned away, or if damaged, replace with new one.

10. When washing air filter, dry it completely before reinstallation.

11. Reinstall air filter and reassemble air cleaner cover.

4-2 Replacing air cleaner cover latch

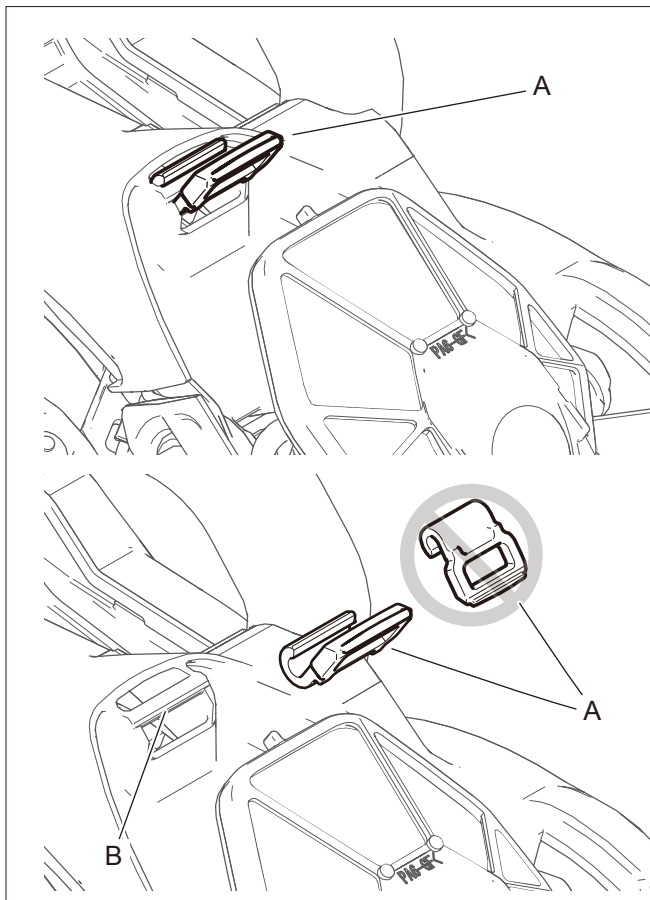

1. Remove air cleaner cover.
2. Remove air cleaner cover latch (A) from rear handle.

3. Install air cleaner cover latch (A) to bar (B) of rear handle as shown.

NOTE: Check air cleaner cover latch (A) for moving smoothly.

4-3 Inspecting fuel cap and fuel strainer

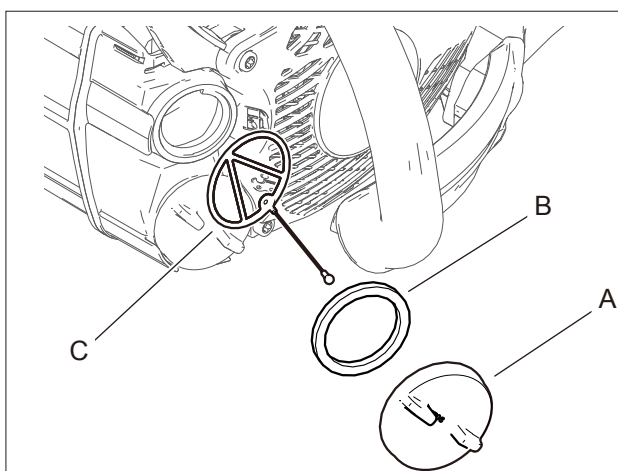

1. Remove fuel cap (A).
2. Inspect fuel cap (A) for cracks and gasket (B) for cuts or damage, and replace with new one as required.
3. Replace connector (C) if damaged.
4. Pull fuel strainer (D) out from fuel tank using a wire hook (E). Clean fuel strainer (D). Replace with new one if defective or heavily soiled.
5. Reinstall fuel cap (A).

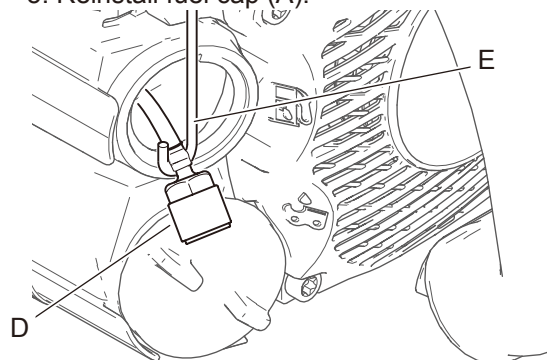

4-4 Inspecting fuel tank and line

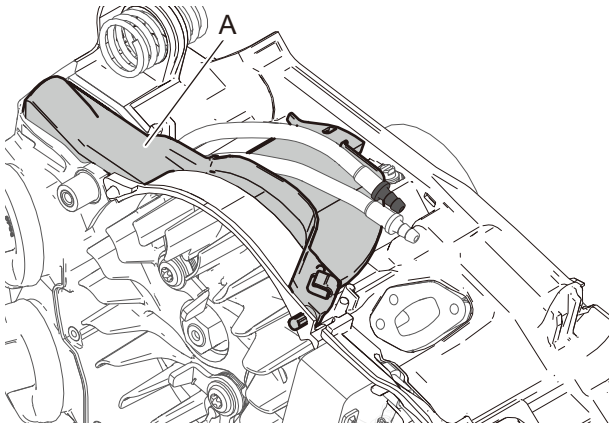

1. Clean fuel tank inside as required.
2. Remove rear handle (Refer to **9-3 Replacing rear handle and springs**).
3. Remove dust cover (A) from engine cover.

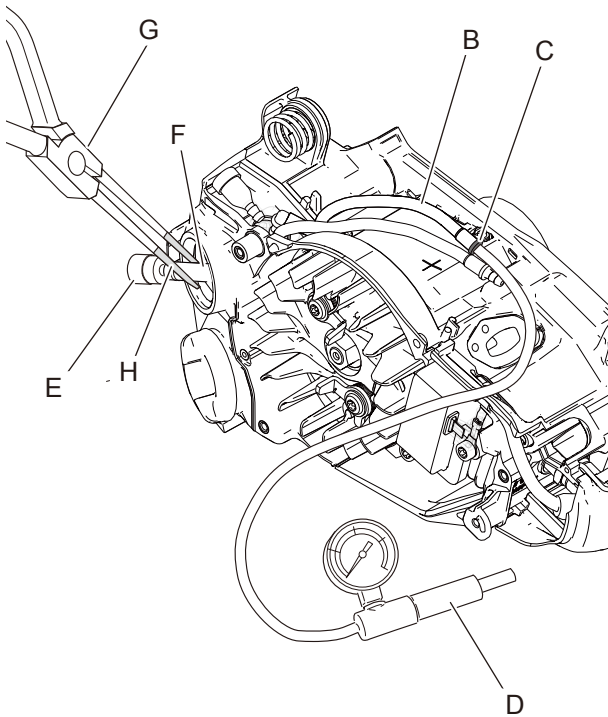

3. Connect fuel line (B) with black joint (C) to pressure tester 897803-30133 (D) as shown.
 4. Remove fuel cap and pull out fuel strainer (E) from the fuel tank.
 5. Pinch fuel line (F) with longnose pliers (G) as shown.
- NOTE:** Wrap the ends of longnose pliers with tape (H) (or cover with soft pipes) to protect fuel line from damage.
6. Apply pressure approx. 50 kPa (0.5 kgf/cm²) (7 psi).
 7. If pressure drops, replace with new fuel line (Refer to **4-7 Replacing fuel line and fuel return line**).
 8. Put fuel strainer in the fuel tank and fasten fuel cap securely.
 9. Apply pressure approx. 10 kPa (0.1 kgf/cm²) (1.4 psi).
 10. Pressure should not drop. If pressure drops, leakage may occur from fuel cap, fuel cap gasket, mating surface of fuel tank, grommet, or tank vent. Inspect and replace defective part(s) with new one.

4-5 Inspecting and replacing tank vent

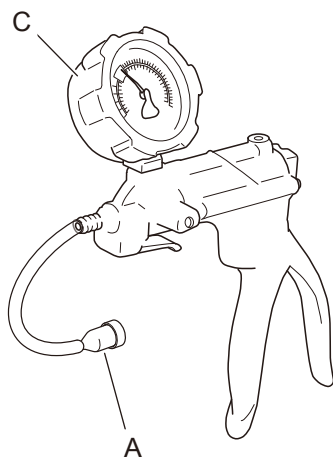
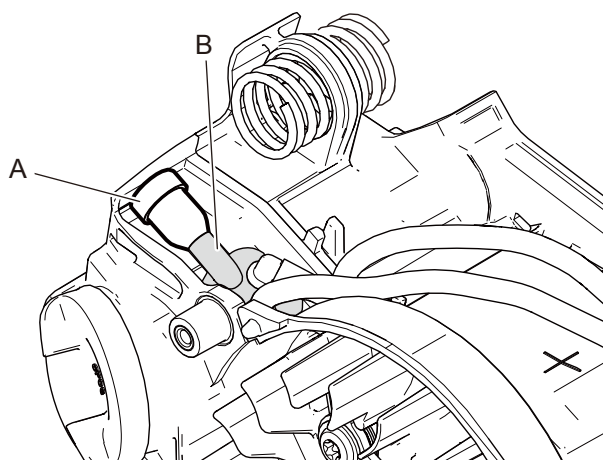

NOTE: Tank vent prevents a vacuum from forming in fuel tank when fuel in fuel tank is being consumed. When pressure in fuel tank becomes too high, tank vent releases the pressure.

1. Remove dust cover (Refer to **4-4 Inspecting fuel tank and line**).

2. Remove tank vent (A) from grommet (B).

3. Connect tank vent (A) to pressure tester 91149 (C).

4. Apply pressure approx. 50 kPa (0.5 kgf/cm²) (7 psi). Make sure pressure is stable in range of 10 - 40 kPa (0.1 - 0.4 kgf/cm²) (1.4 - 5.7 psi).

5. If it is not in the range, gently clean tank vent with compressed air or replace with new one.

NOTE: Do not disassemble valves in tank vent assembly. Damage to valves will occur.

6. Apply negative pressure 20 kPa (0.2 kgf/cm²) (3 psi).

7. Tank vent should pass air freely without holding any pressure. If it does not, replace tank vent with new one.

4-5 Inspecting and replacing tank vent (continued)

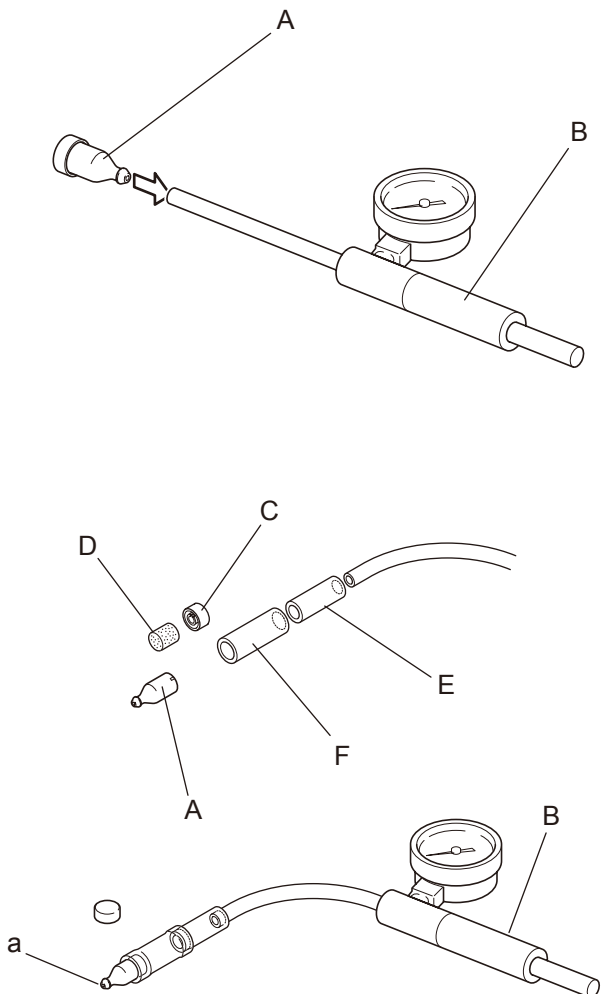

NOTE: Inspection using 897803-30133

If pressure tester 91149 is not available, tank vent can be inspected with pressure tester 897803-30133 as follows.

1. Connect tank vent (A) to pressure tester 897803-30133 (B).
2. Apply pressure approx. 50 kPa (0.5 kgf/cm²) (7 psi). Make sure pressure is stable in range of 10 - 40 kPa (0.1 - 0.4 kgf/cm²) (1.4 - 5.7 psi).
3. If it is not in the range, gently clean tank vent with compressed air or replace with new one.

NOTE: Do not disassemble valves in tank vent assembly. Damage to valves will occur.

4. Remove cap (C) of tank vent, and clean sponge (D).
5. Cut pipe 363011-00210 (E: 7x11x170mm) and 382011-01110 (F: 9x13x350) in approx. 30mm (1 1/4 in) length, and connect them to pressure tester as shown. Connect tank vent (A) without cap to pipe as shown.
6. Plug hole (a) with finger and apply pressure 20 kPa (0.2 kgf/cm²) (3 psi). The pressure should hold steady.
7. Remove finger from hole (a). Tank vent should pass air freely without holding any pressure. If it does not, replace tank vent with new one.

4-6 Replacing purge bulb

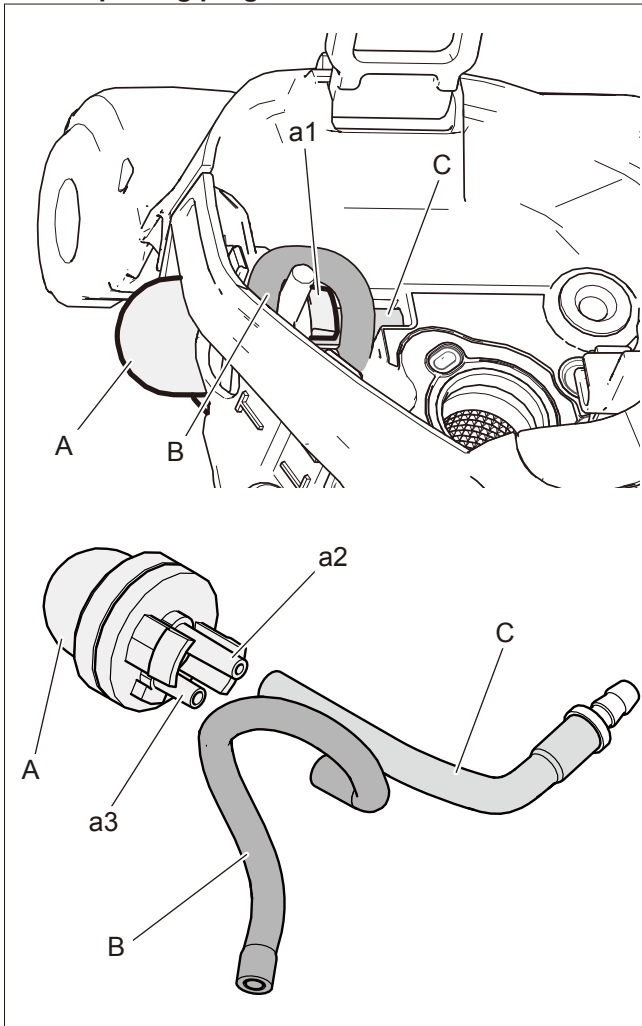

{Removing}

1. Remove rear handle (Refer to **9-3 Replacing rear handle and springs**).
2. Press leg (a1) of purge bulb (A) with screwdriver to remove purge bulb (A) from rear handle.
3. Disconnect purge line (B) and fuel return line (C) from purge bulb (A).

{Installing}

4. Connect fuel return line (C) to longer fitting (a2) of purge bulb (A). Connect purge line (B) to shorter fitting (a3) of purge bulb (A).
5. Install purge bulb (A) with fuel return line (C) and purge line (B) into rear handle.
6. Reassemble removed parts.

4-7 Replacing fuel line and fuel return line

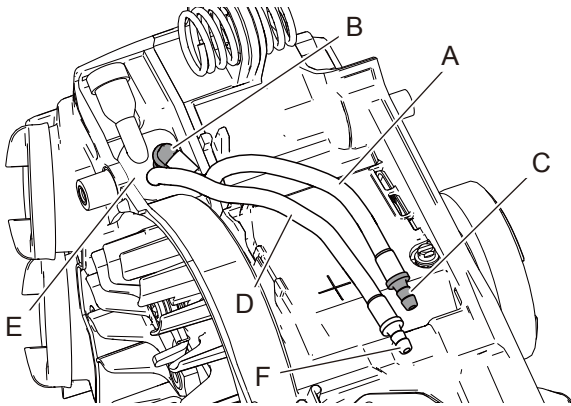
**{Removing}**

1. Remove dust cover (Refer to 4-4 Inspecting fuel tank and line).
2. Disconnect fuel line (A) from black joint (B) and (C). Inspect fuel line (A) and replace with new one if defective.
3. Disconnect fuel return line (D) from grommet (E) and white joint (F). Inspect fuel line (D) and replace with new one if defective.

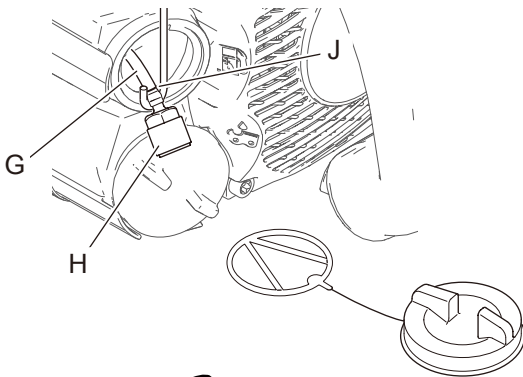

4. To replace fuel line (in fuel tank) (G), remove fuel cap and remove fuel strainer (H) and clip (J) from fuel line (G).

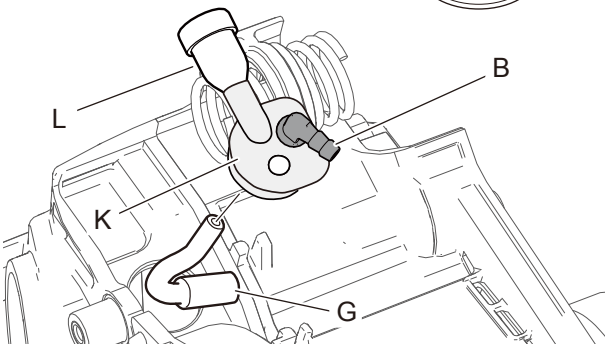

5. Remove grommet (K) from the unit together with fuel line (G), black joint (B) and tank vent (L).
6. Remove fuel line (G), black joint (B) and tank vent (L) from grommet (K).
7. Inspect fuel line (G), joint (B) and grommet (K). Replace with new one if defective.

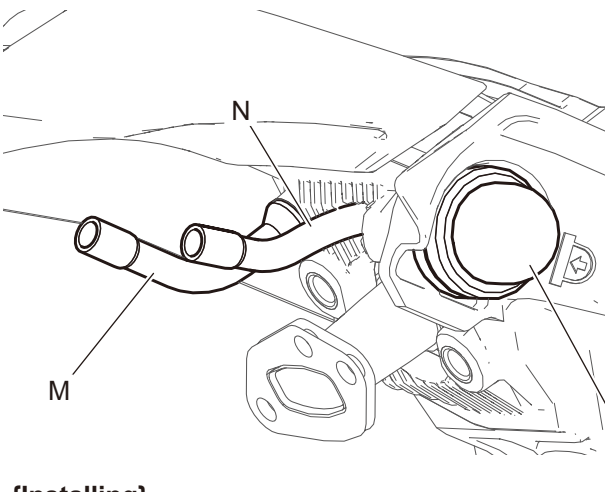

8. Remove fuel line (M) from rear handle and fuel return line (N) from purge bulb (P).
9. Inspect fuel line (M) and fuel return line (N). Replace with new one if defective.

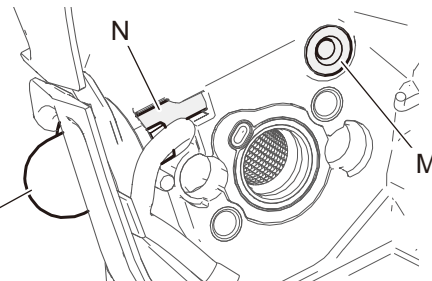
**{Installing}**

10. Install fuel line (M) to rear handle.
11. Install fuel return line (N) to purge bulb (P).

4-7 Replacing fuel line and fuel return line (continued)

12. Reinstall fuel line (G) through grommet (E) as shown.

13. Connect fuel line (A) and (G), using black joint (B).

NOTE: Make sure of black joint (B) direction.

14. Pull fuel line (G) toward fuel tank side.

NOTE: Push black joint (B) in grommet (E) as brim (b) of joint (B) touches grommet (E).

15. Adjust direction of fuel line (A) and joint (B) as view (R).

16. Reinstall fuel return line (D) through grommet (E) as shown.

17. Reinstall assembled grommet (E) on the unit as shown.

18. Connect black joint (C) to fuel line (A)

19. Connect white joint (F) to fuel return line (D).

20. Connect black joint (C) to fuel line (M).

21. Connect white joint (F) to fuel return line (N).

22. Reassemble removed parts.

4-8 Adjusting carburetor

4-8-1 General adjusting rules

A. Before starting the unit for adjustment, check the following items.

1. The correct spark plug must be clean and properly gapped.
2. The air filter element must be clean and properly installed.
3. The muffler exhaust port must be clear of carbon.
4. The fuel lines, tank vent and fuel filter are in good condition and clear of debris.
5. The fuel is fresh (> 89 octane : RON) and properly mixed at 50 : 1 with "ISO L-EGD" or "JASO FC/FD" 2-stroke oil.
6. 20, 25 or 30 cm bar and chain must be installed, and properly tensioned.

B. Engine speed confirmation

Start and run engine for 100 seconds alternating engine speed between WOT 5 seconds and idle 5 seconds. Verify idle engine speed ranges from 3,100 to 3,300 r/min, and WOT engine speed ranges 12,800 to 13,400 r/min. If idle and WOT engine speeds are out of the range, proceed to the next step 4-8-2.

4-8-2 Initial setting Throttle adjust screw, L mixture needle and H mixture needle

Tools Required : P/N 897802-33330 Tachometer PET-1000R, P/N Y089-000095 Carburetor adjustment tool (Large D-shaped tool (A))

1. Turn L and H mixture needles clockwise until lightly seated, and then turn out both mixture needles following turns.
 - L mixture needle (B) : 2 1/2**
 - H mixture needle (C) :**
 - 1 3/4 (Mixed two-stroke regular fuel)
 - 2 (Mixed two-stroke E10 fuel)
 - 2 1/4 (Premixed alkylate fuel)

NOTE : If needles are overtightened during seating, damage to carburetor may occur.

2. Remove air cleaner cover and air filter to see the throttle adjust screw (D) contacts the throttle plate (E) (Fig.1). Turn the screw (D) counterclockwise until its tip no longer touches the throttle plate (E) (Fig.2). Then turn the screw (D) clockwise until its tip just comes into contact with the plate (E) again (Fig.3). Finally, turn the screw (D) 1 1/2 turns clockwise. Reinstall air filter and air cleaner cover.

NOTE : The initial carburetor settings for throttle adjust screw, L and H mixture needles are intended to start and run the engine before final carburetor adjustments are made to conform the unit to meet Emission Directive. The actual number of turns needed for engine operation may vary.

4-8 Adjusting carburetor (continued)

4-8-3 Adjusting carburetor

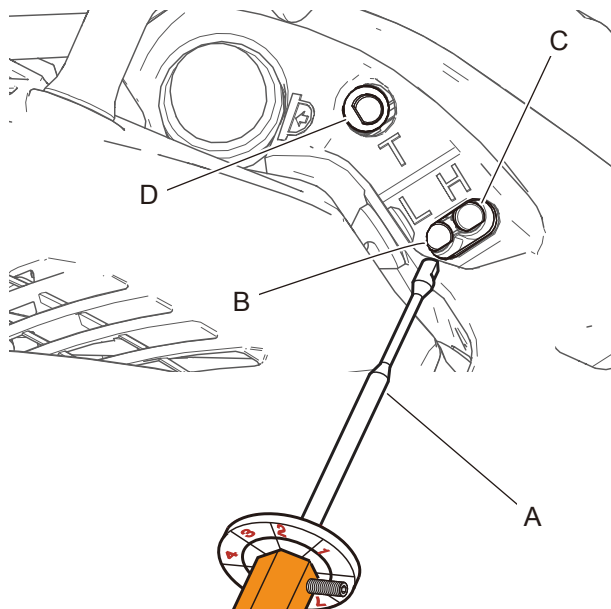

PI controller installed model has 2 mode; Carburetor adjustment mode and Operation mode.

When adjusting carburetor, must be changed from Operation mode to Carburetor adjustment mode in the following steps.

1. Start engine without brake activated. Do not touch throttle lever.

2. Warm up engine with fast idle for 120 seconds. The speed should be within 6,000 - 10,000 r/min. If it is not, adjust the speed by turning H mixture needle.

CAUTION: Chain will start to rotate during engine warm-up with fast idle.

NOTE: Do not stop engine during carburetor adjustment. If the engine is stopped, start above steps from the beginning.

3. Warm up engine for 30 seconds alternating engine speed between WOT 5 seconds and idle 5 seconds.

4. Confirm to vary the idle speed by turning L mixture needle 1/4 turn clockwise. If the speed does not vary, change the mode again.

NOTE: The idle engine speed returns to 3,200 r/min for a few second in Operation mode, when the engine speed is deviated.

5. Adjust L mixture needle (B) using D-shaped tool (A) to reach maximum engine speed just before lean drop off.

If chain starts to rotate during adjustment, decrease engine speed by turning throttle adjust screw (D) counterclockwise until chain stops and then readjust L mixture needle (B).

6. Set idle engine speed to 4,100 r/min by turning Throttle adjust screw (D). Engine speed should be stable at 4,100 +/- 50 r/min after Throttle adjust screw adjustment.

7. Turn L mixture needle (B) counterclockwise reducing engine idle speed 800 r/min to set idle speed at 3,300 r/min. The engine idle speed ranges 3,200 - 3,400 r/min.

NOTE : Engine speed must be allowed to stabilize a minimum of 20 seconds after each adjustment of L mixture needle to assure accurate tachometer readings.

8. Stop engine and restart engine. Verify engine idle speed ranges from 3,100 to 3,300 r/min, and WOT engine speed ranges from 12,800 to 13,400 r/min. If the WOT speed is not within above range, return to "4-8-2 Initial setting" and set H mixture needle again. If that does not work, adjust H mixture needle by 1/8 turn. Make sure the chain does not rotate when engine is idling. When final adjustment is completed, the engine should idle, accelerate smoothly, and attain WOT per above specifications.

9. Confirm clutch engagement speed. If it is less than 1.25 times the idle speed, adjust the idle speed by turning TAS counterclockwise.

NOTE: WOT engine speed in field operation may vary from final adjustment specifications due to changing ambient conditions and fuel. Safe engine speed variances should be within the WOT and Idle engine speed ranges listed in Section "1-2 Technical data", otherwise the carburetor should be readjusted.

4-9 Testing carburetor

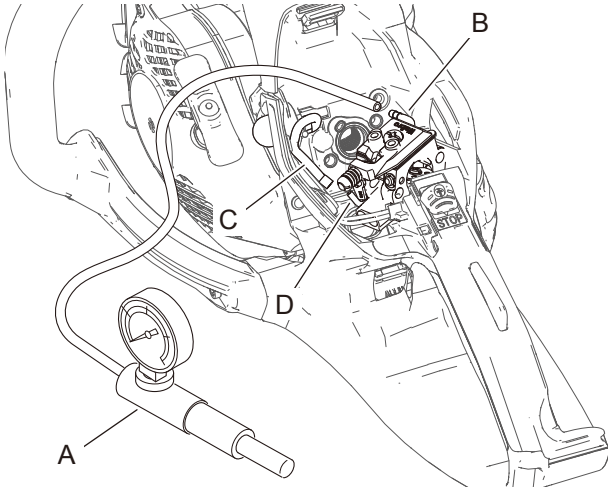

NOTE: To perform this test, carburetor interior should be wet with fuel. If dry, a little leakage may occur.

1. Remove air cleaner cover, air filter and carburetor.
2. Connect pressure tester 897803-30133 (A) to carburetor fitting (B).
3. Reinstall purge line (C) to carburetor fitting (D).
4. Apply pressure approx. 100 kPa (1 kgf/cm²) (14 psi).
5. If pressure remains steady, follow step 6 and 7. If pressure drops, proceed to step 8.
6. Lightly push purge bulb once. Pressure tester reading should drop and remain 50 kPa (0.5 kgf/cm²) (7 psi) or more.
7. If reading does not drop, inspect inlet needle valve for sticking (Refer to **4-12 Inspecting inlet needle valve**) or metering lever height is too low (Refer to **4-11 Inspecting metering lever height**).

If pressure remain 50 kPa (0.5 kgf/cm²) (7 psi) or more, remove carburetor and inspect carburetor following step 9.

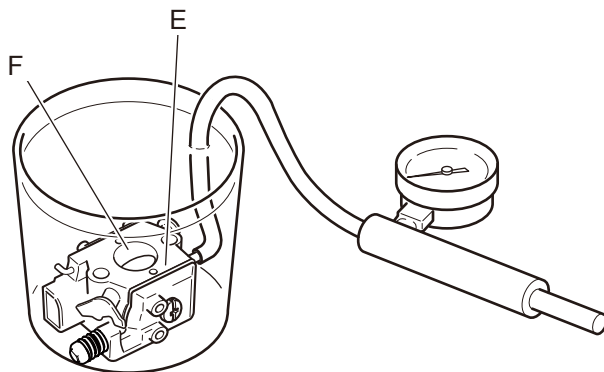

8. If pressure drops at step 4, remove carburetor.
9. Submerge carburetor in suitable clean solvent to locate the leak by applying pressure approx. 100 kPa (1 kgf/cm²) (14 psi).
10. If air bubbles come out between pump cover and carburetor body (E), inspect pump diaphragm, pump gasket, and diaphragm seat of carburetor body (Refer to **4-13 Inspecting diaphragm and others**).
11. If air bubbles come out from throttle bore (F), inspect inlet valve, metering lever spring, and metering lever height (Refer to **4-12 Inspecting inlet needle valve** and **4-11 Inspecting metering lever height**).
12. Reassemble removed parts.

4-10 Inspecting crankcase pulse passage

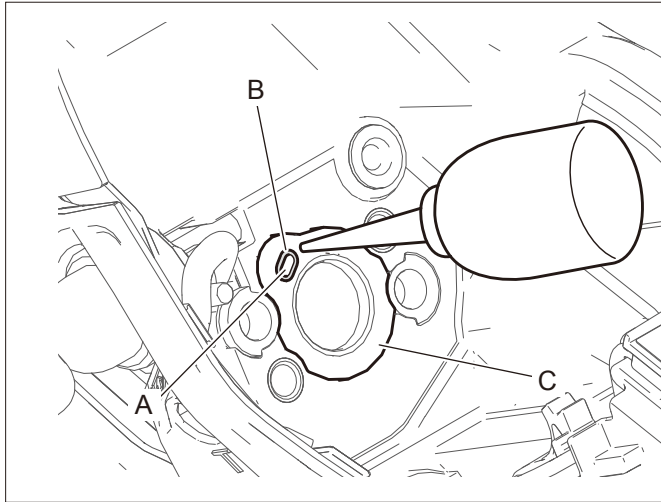

1. Remove carburetor.
2. Drop a little oil in pulse hole (A).
3. Remove spark plug and pull starter grip several times. Oil should spit back from the hole (A).
4. If not, remove collar (B) and inspect whether pulse passage of collar (B), intake bellows (C) and cylinder are clogged. Remove obstruction or replace with new one as required.

4-11 Inspecting metering lever height

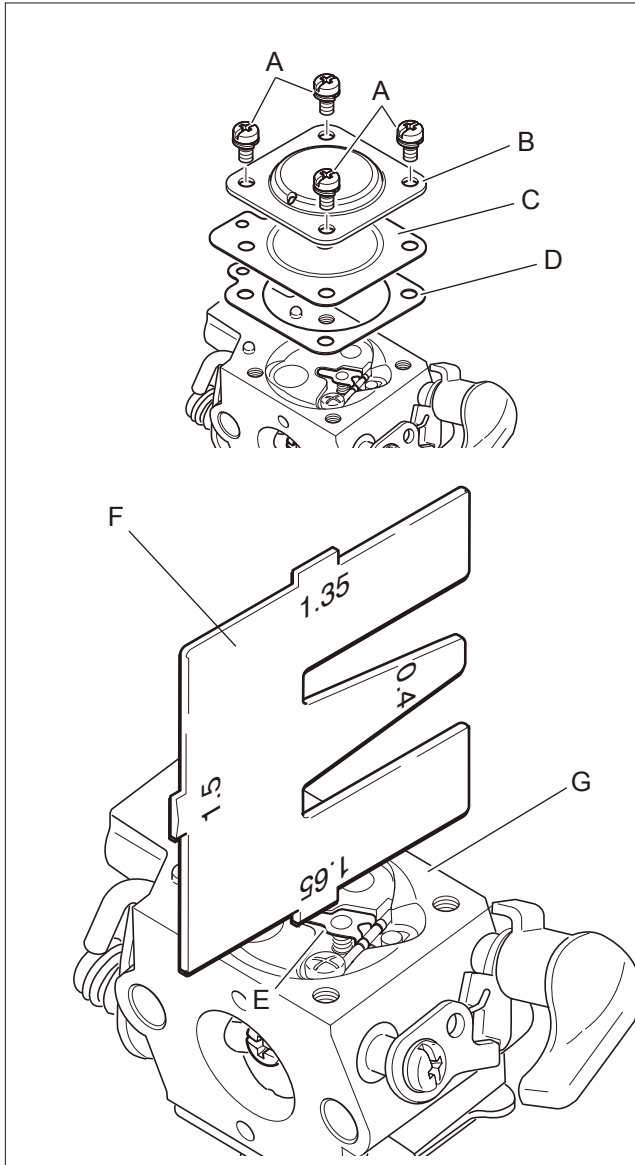

1. Remove carburetor.
2. Remove four screws (A), metering diaphragm cover (B), metering diaphragm (C) and gasket (D).

3. Inspect metering lever (E) height by Metering lever gauge 897563-19830 (F).

Metering lever height: 1.65 mm (0.065 in) lower than diaphragm seat (G).

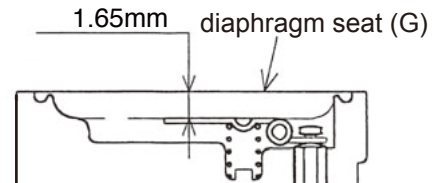

4. If necessary, gently bend metering lever (E) up or down to set metering lever to proper position.

NOTE: When metering lever is:

- Too high → Fuel flooding occurs
- Too low → Fuel starvation / overheating occurs

4-12 Inspecting inlet needle valve

1. Remove metering lever (A) and pivot pin. Remove spring (B) and inlet needle valve (C).

2. Inspect inlet needle valve if worn or sticky. Clean or replace as required.

NOTE: Causes of fuel flooding from carburetor to cylinder are as follows:

- Improper assembling of metering lever and spring.
- Dirt between inlet needle valve and valve seat.
- Worn inlet needle valve tip.

3. Clean inlet needle valve seat using suitable clean solvent (do not use metal tools).

4. Reassemble inlet needle valve (C), spring (B), metering lever (A) and pivot pin.

NOTE: Insure proper metering lever installation as follows.

- (1) Spring is seated in its hole at chamber floor.
- (2) Spring is under dimple of metering lever.
- (3) Metering lever fork is holding inlet needle valve.

4-13 Inspecting diaphragm and others

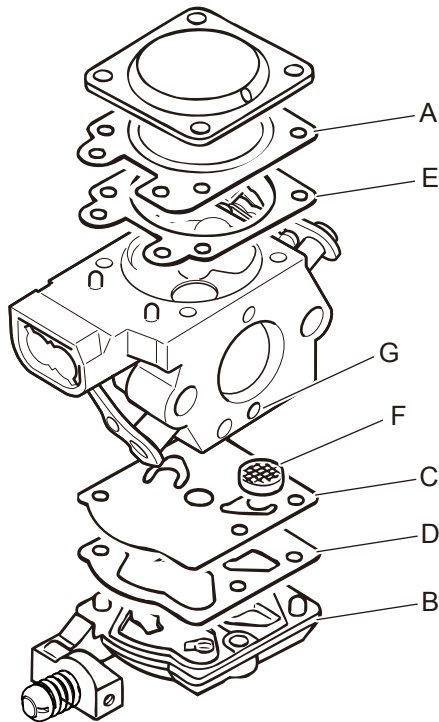

1. Inspect metering diaphragm (A) for hardening, distortion, or pin hole. Replace as required.
2. Remove pump cover (B), pump diaphragm (C) and pump gasket (D).
3. Inspect pump diaphragm (C) and replace if hardened or curled at valve tabs.
4. Make sure pulse chamber is clear of debris. If not, clean it.
5. Inspect metering gasket (E) and pump gasket (D) and replace if defective.
6. Inspect inlet screen (F). If blocked, remove and clean it, or replace.
7. Clean pulse passage (G) with compressed air.
8. Clean fuel passages in carburetor body with compressed air.

NOTE: Before cleaning metering side with compressed air, turn “H” needle clockwise until lightly seated and remove inlet needle valve. Otherwise, main nozzle check valve and inlet needle valve spring may be damaged by the compressed air.

9. Reassemble removed parts with particular attention to each aspect.

4-14 Replacing welch plug

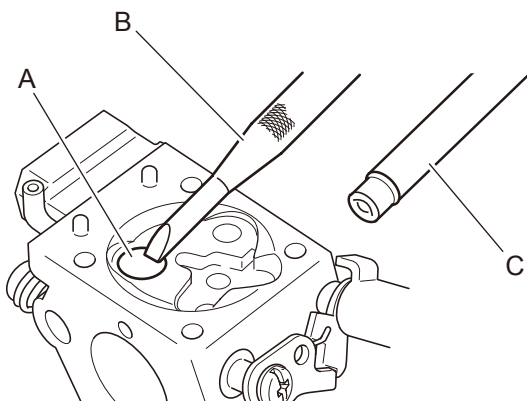

If engine does not run smoothly even after readjusting carburetor and inspecting carburetor parts, inspect low speed ports on carburetor as follows:

1. Remove metering lever and related parts to protect them from damage.
2. To remove welch plug (A), punch the remover tool (B) through welch plug at low angle and pry it out.

NOTE: Remover tool (B) is included in Welch plug tool 500-500.

3. Clean low speed ports with compressed air.
4. Place a new welch plug over the opening and gently tap it until flush using welch plug installer (C).
5. Install all removed parts to carburetor body.

4-15 Installing carburetor

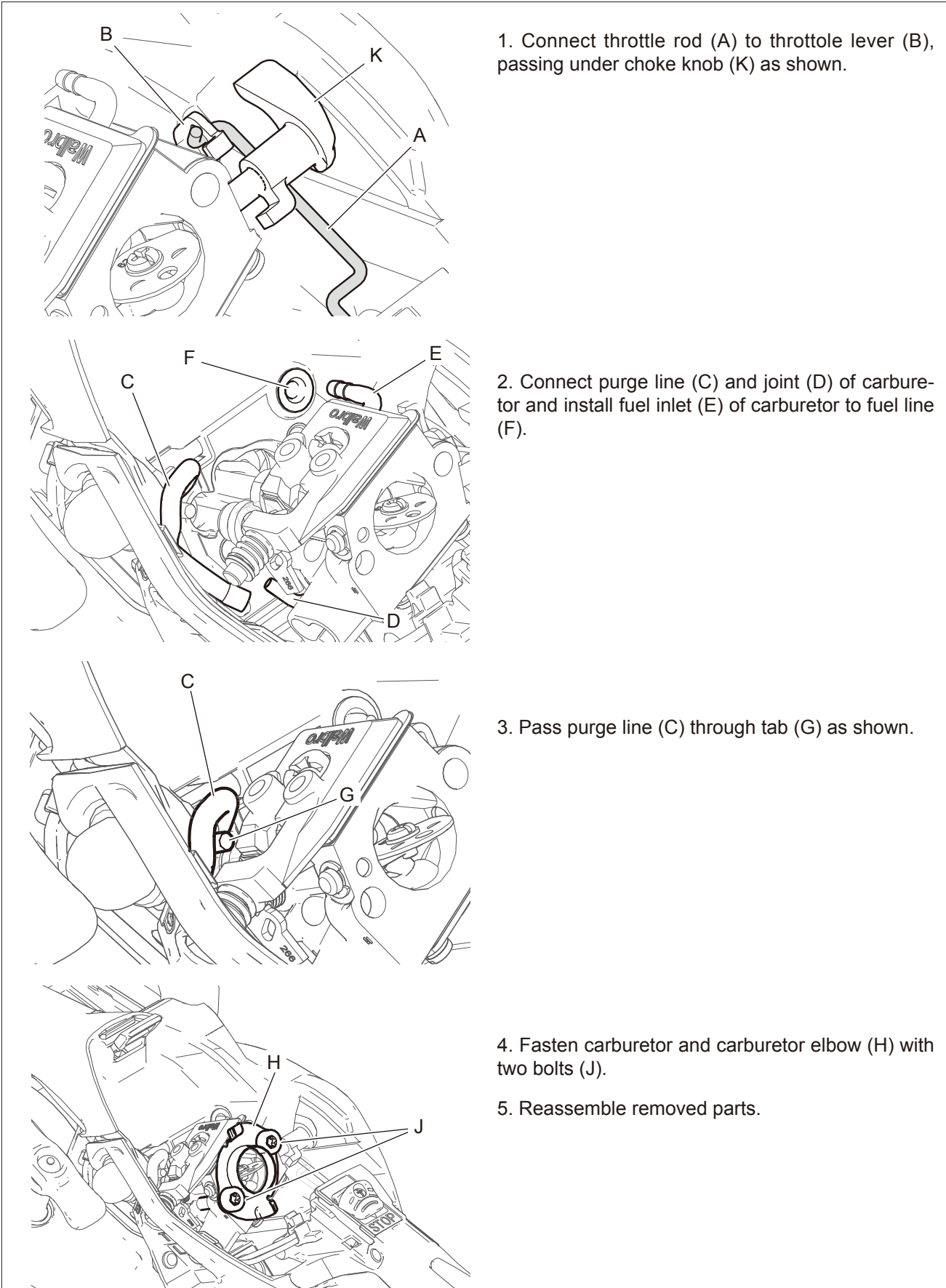

1. Connect throttle rod (A) to throttle lever (B), passing under choke knob (K) as shown.

2. Connect purge line (C) and joint (D) of carburetor and install fuel inlet (E) of carburetor to fuel line (F).

3. Pass purge line (C) through tab (G) as shown.

4. Fasten carburetor and carburetor elbow (H) with two bolts (J).

5. Reassemble removed parts.

5 CLUTCH SYSTEM

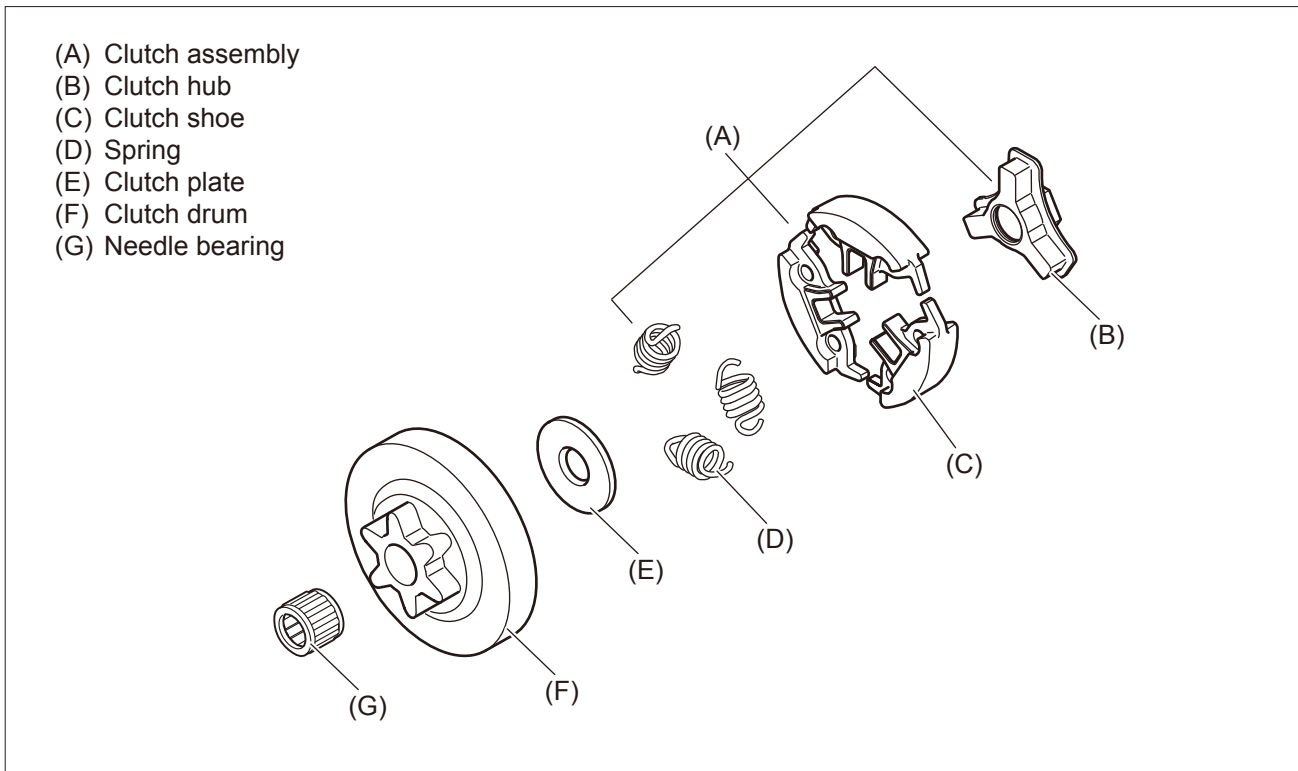

5-1 Inspecting clutch parts

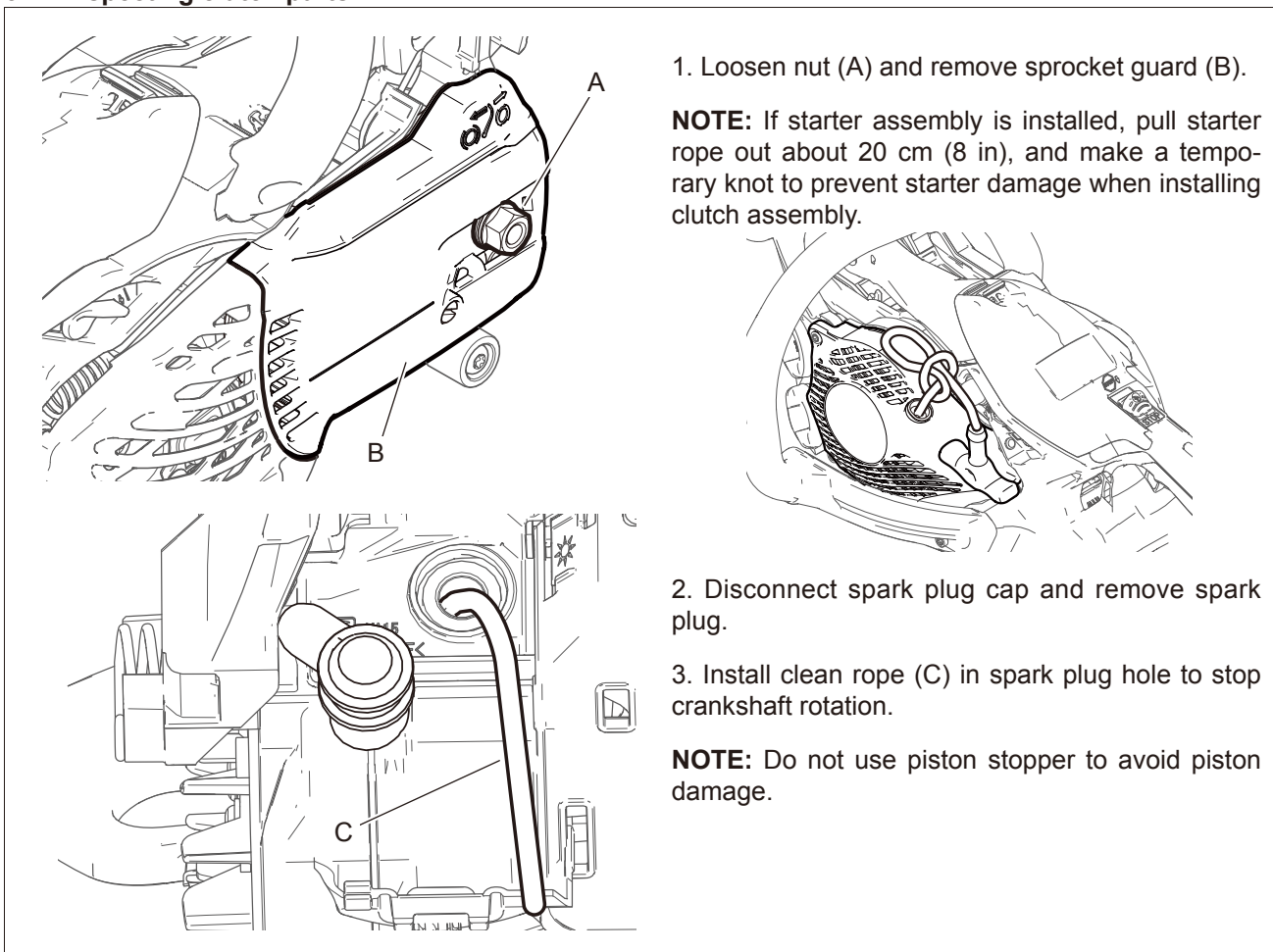

5-1 Inspecting clutch parts (continued)

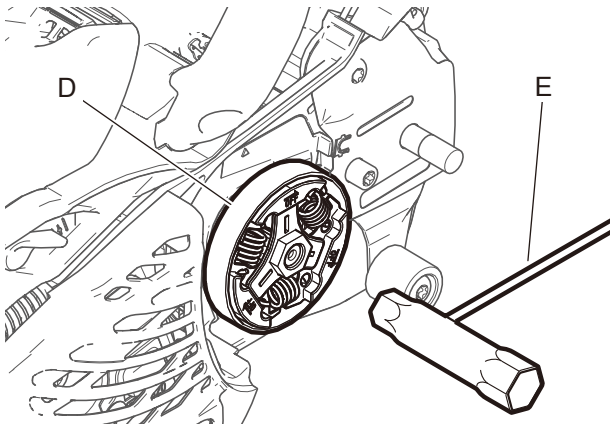

4. Rotate clutch assembly (D) clockwise by hand until it cannot be rotated further.

5. Remove clutch assembly (Left-hand thread) (D), rotating with wrench (E).

NOTE: Do not use power tools. Otherwise, piston damage may occur.

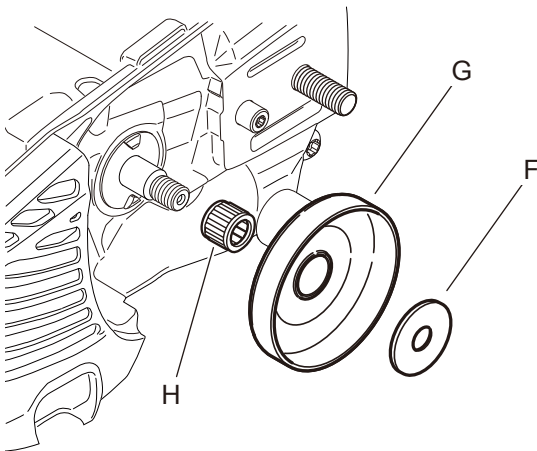

6. Remove clutch plate (F), clutch drum (G), needle bearing (H).

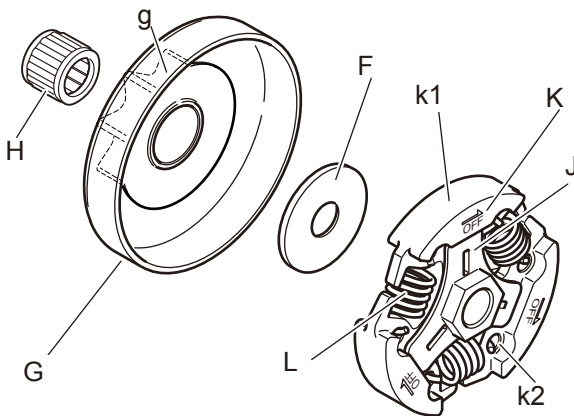

7. Inspect matching surfaces of clutch hub (J) and clutch shoes (K). If their clearances are large, replace with new parts.

8. Inspect circumferences (k1) and holes (k2) hooked springs (L) for wear. Replace with new parts as required.

9. Inspect clutch plate (F) for wear. Replace with new one as required.

10. Inspect springs (L) for weakness or damage. Replace with new parts as required.

11. Inspect clutch drum (G) and its sprocket (g). Replace with new one if deformed or worn out (Refer to **1-5 Service limits**).

12. Inspect needle bearing (H) for damage, discoloration or deformation. Replace with new one as required.

5-2 Replacing clutch parts

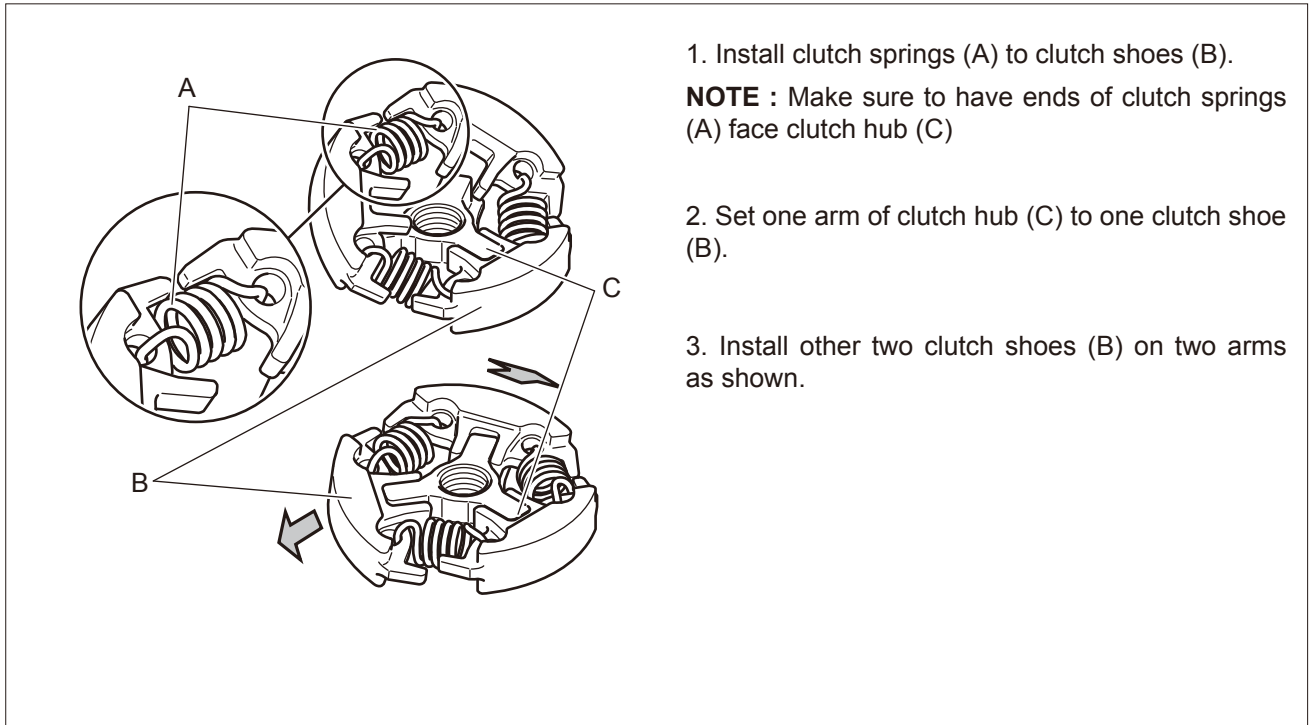

1. Install clutch springs (A) to clutch shoes (B).
NOTE : Make sure to have ends of clutch springs (A) face clutch hub (C)
2. Set one arm of clutch hub (C) to one clutch shoe (B).
3. Install other two clutch shoes (B) on two arms as shown.

5-3 Installing clutch assembly

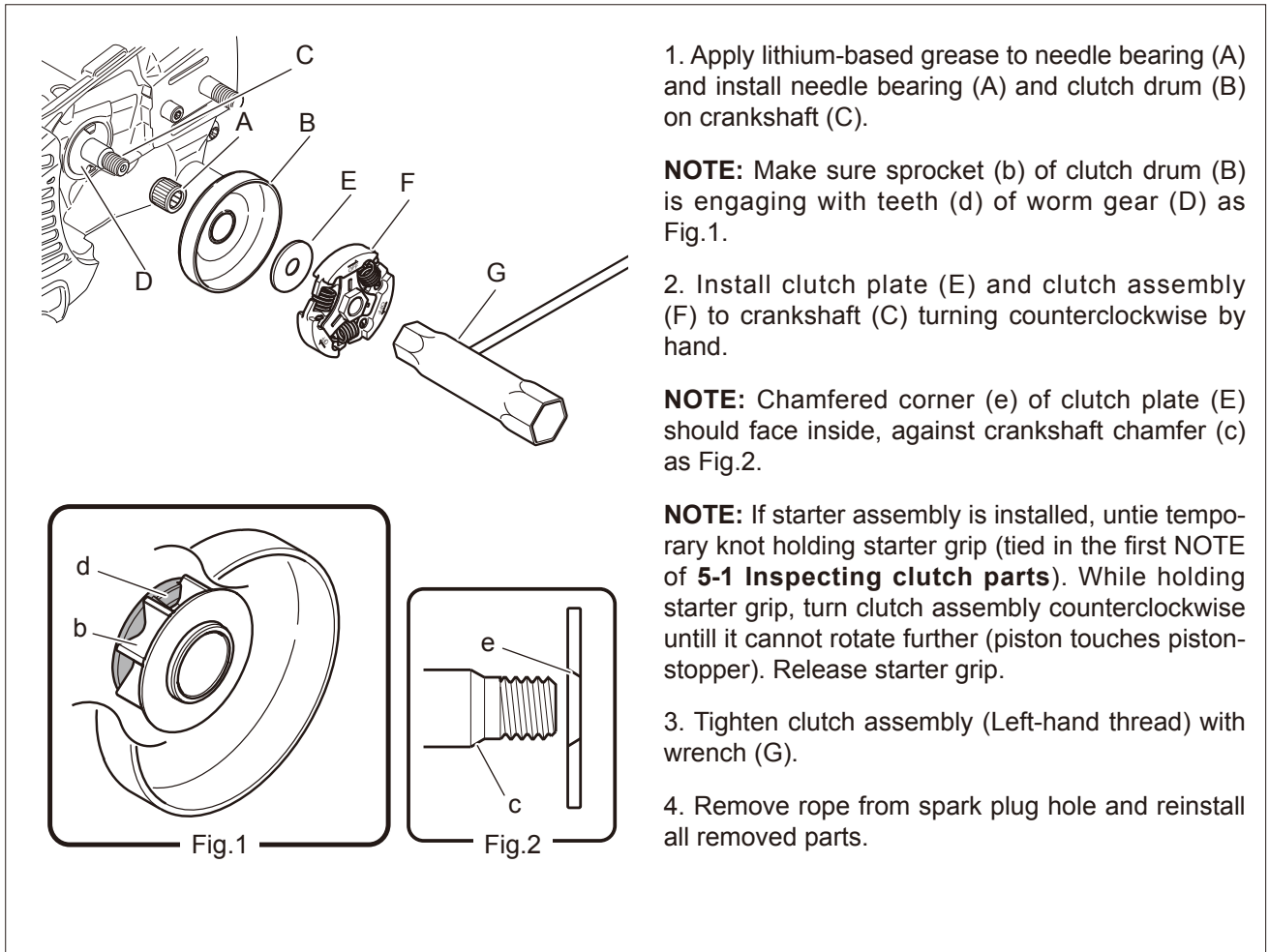

1. Apply lithium-based grease to needle bearing (A) and install needle bearing (A) and clutch drum (B) on crankshaft (C).
NOTE: Make sure sprocket (b) of clutch drum (B) is engaging with teeth (d) of worm gear (D) as Fig.1.
2. Install clutch plate (E) and clutch assembly (F) to crankshaft (C) turning counterclockwise by hand.
NOTE: Chamfered corner (e) of clutch plate (E) should face inside, against crankshaft chamfer (c) as Fig.2.
- NOTE:** If starter assembly is installed, untie temporary knot holding starter grip (tied in the first NOTE of 5-1 Inspecting clutch parts). While holding starter grip, turn clutch assembly counterclockwise until it cannot rotate further (piston touches piston-stopper). Release starter grip.
3. Tighten clutch assembly (Left-hand thread) with wrench (G).
4. Remove rope from spark plug hole and reinstall all removed parts.

6 CHAIN BRAKE SYSTEM

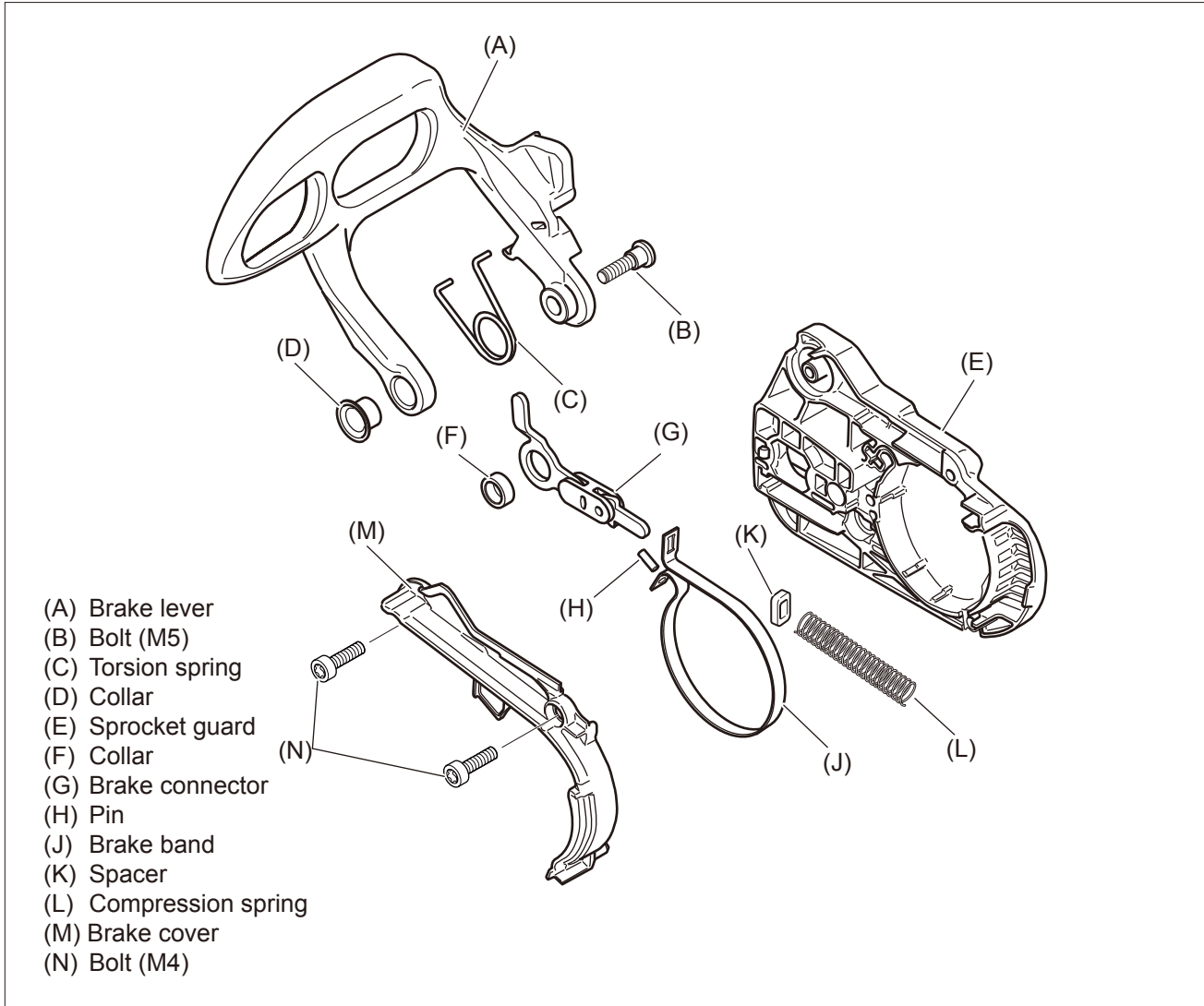

6-1 Replacing brake lever and torsion spring

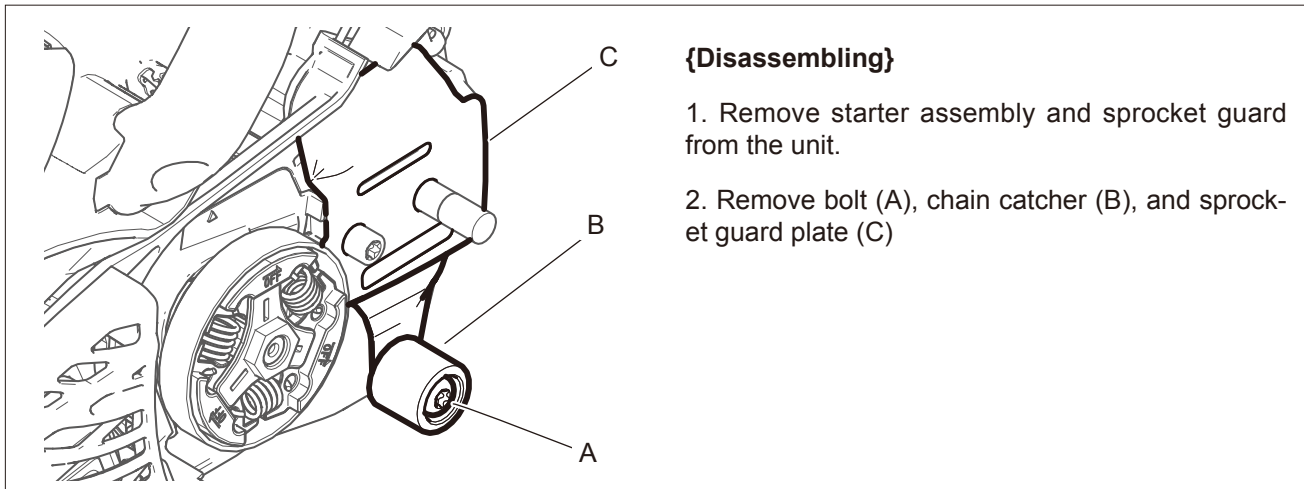

6-1 Replacing brake lever and torsion spring (continued)

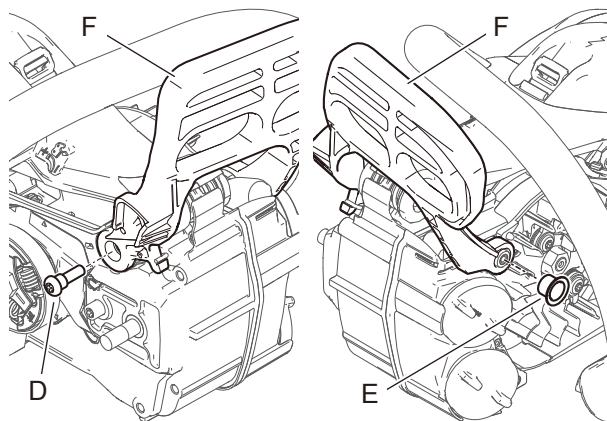

3. Remove bolt (D) using torx wrench (T25).
4. Remove collar (E), then remove brake lever (F).

WARNING  **DANGER**

Wear eye protection and take care when removing brake lever. Torsion spring may come out suddenly and cause personal injury.

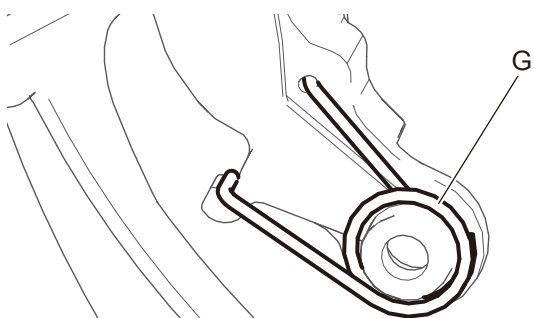

5. Remove torsion spring (G) from brake lever (F)
6. Check brake lever (F) if broken, and torsion spring (G) if deformed or broken. Replace with new part(s) if defective.

{Assembling}

7. Assemble torsion spring (G) as shown.

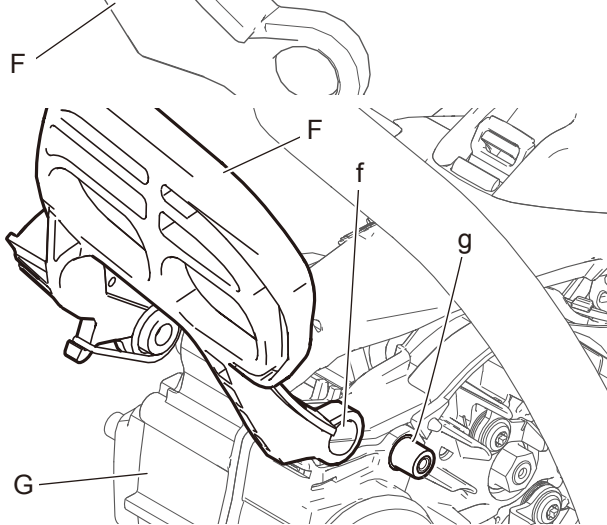

8. Put hole (f) of brake lever (F) on boss (g) of engine cover (G).

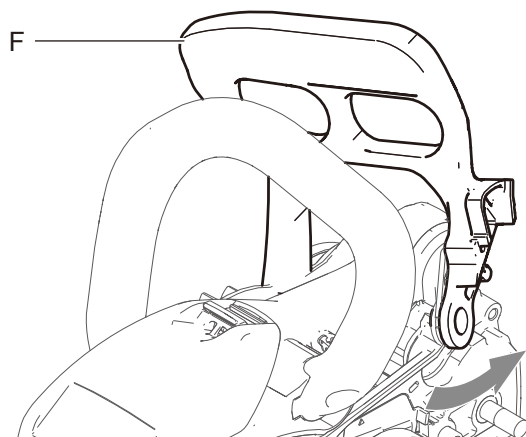

9. Assemble brake lever (F) as shown.
10. Tighten bolt (D) and insert collar (E) (Refer to steps 3 and 4).
11. Reassemble removed parts.

6-2 Inspecting chain brake parts

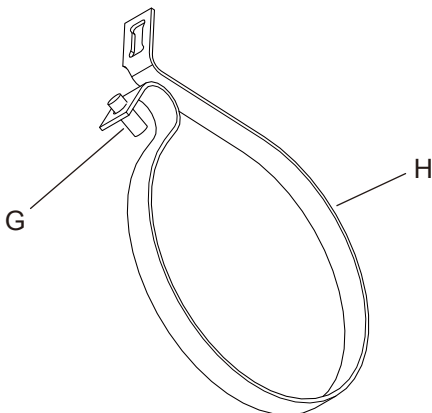
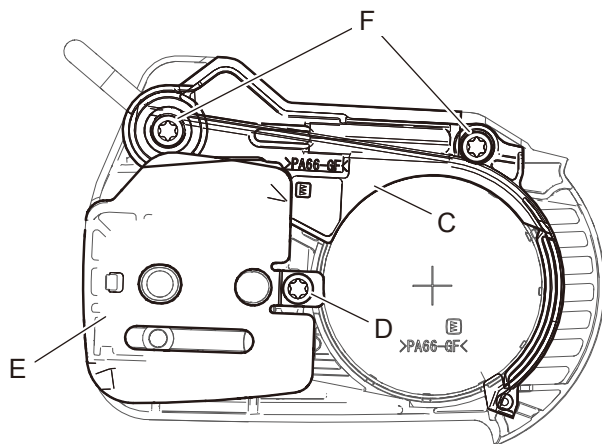
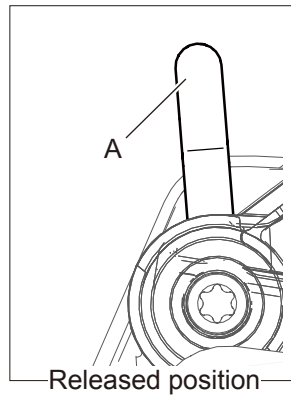
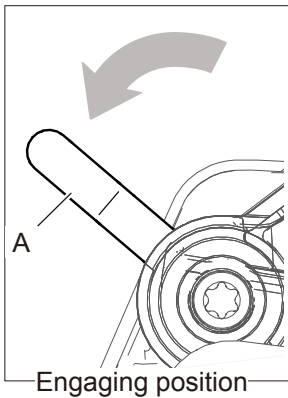
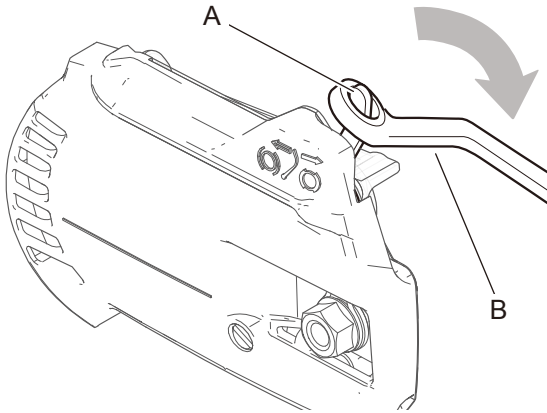
**WARNING**  **DANGER**

Wear eye protection and safety gloves when disassembling or assembling chain brake to protect eye and hand from injury.

{Disassembling}

1. Remove sprocket guard.
2. Move brake connector (A) with ring wrench (B) or other suitable tool as shown. And make brake connector engaging position.

NOTE: Make sure that brake connector (A) is in engaging position before removing brake cover (C), otherwise compression spring may jump out.

3. Remove bolt (D) and sprocket guard plate (E).
4. Loosen two bolts (F) securing brake cover (C) and then remove brake cover (C).
5. If blocked with dirt or dust, clean around brake parts.
6. Inspect all the brake parts for damage. Replace with new part(s) as required.

{Assembling}

7. Install pin (G) through hole of brake band (H) as shown.

6-2 Inspecting chain brake parts (continued)

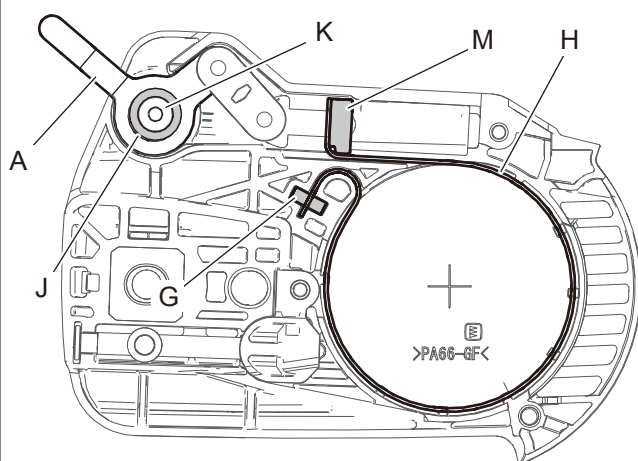

8. Apply molybdenum grease to collar (J), and then put collar (J) on boss (K) of sprocket guard.

9. Set brake connector (A), brake band (H) with pin (G) and spacer (M) in sprocket guard as shown .

Note : Make sure notch (m) of spacer (M) places as shown.

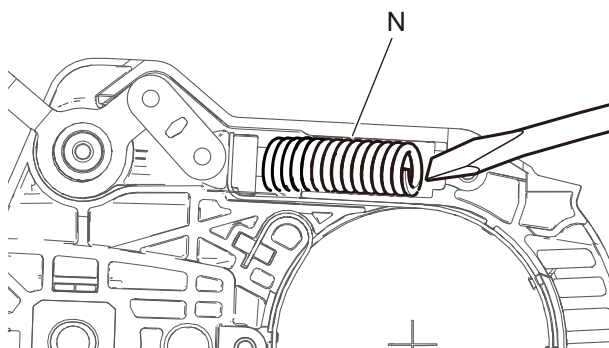
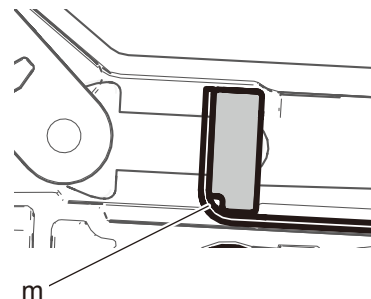

10. Push compression spring (N) with driver or other suitable tool and install compression spring (N) in sprocket guard as shown.

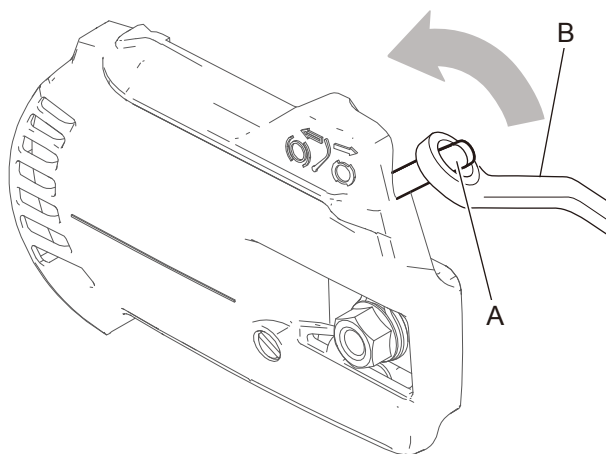
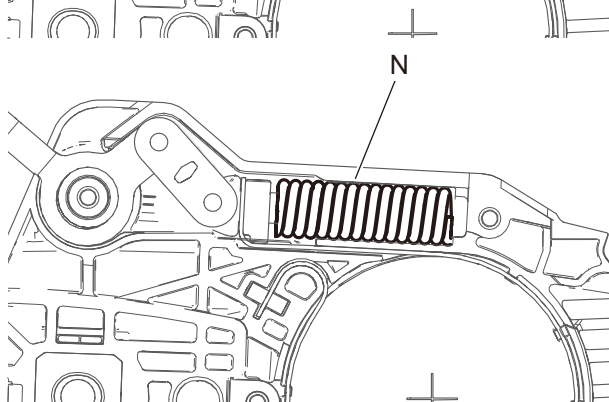

11. Install brake cover (C) with two bolts (F) and sprocket guard plate (E) with bolt (D) (Refer to steps 3 and 4).

12. Move brake connector (A) with ring wrench (B) or other suitable tool to released position as shown.

13. Reassemble removed parts.

7 SAW CHAIN LUBRICATION SYSTEM

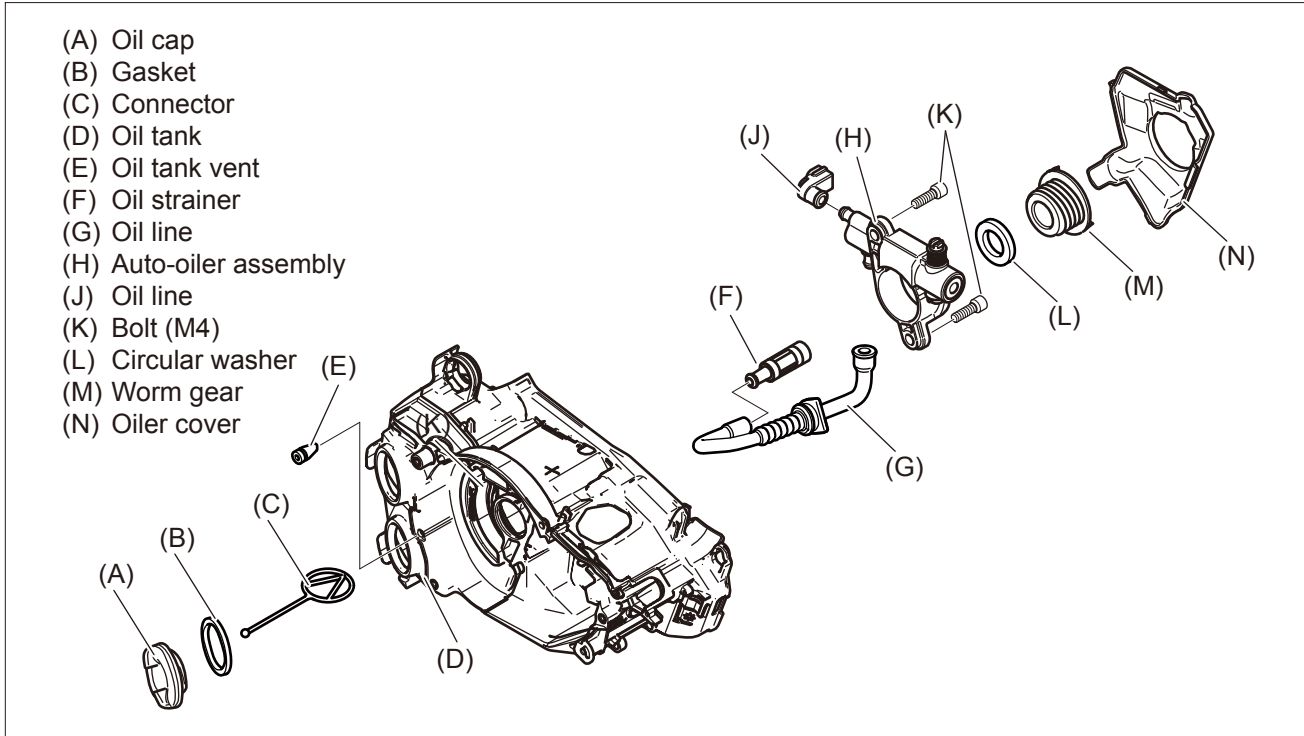

7-1 Inspecting oil cap and strainer

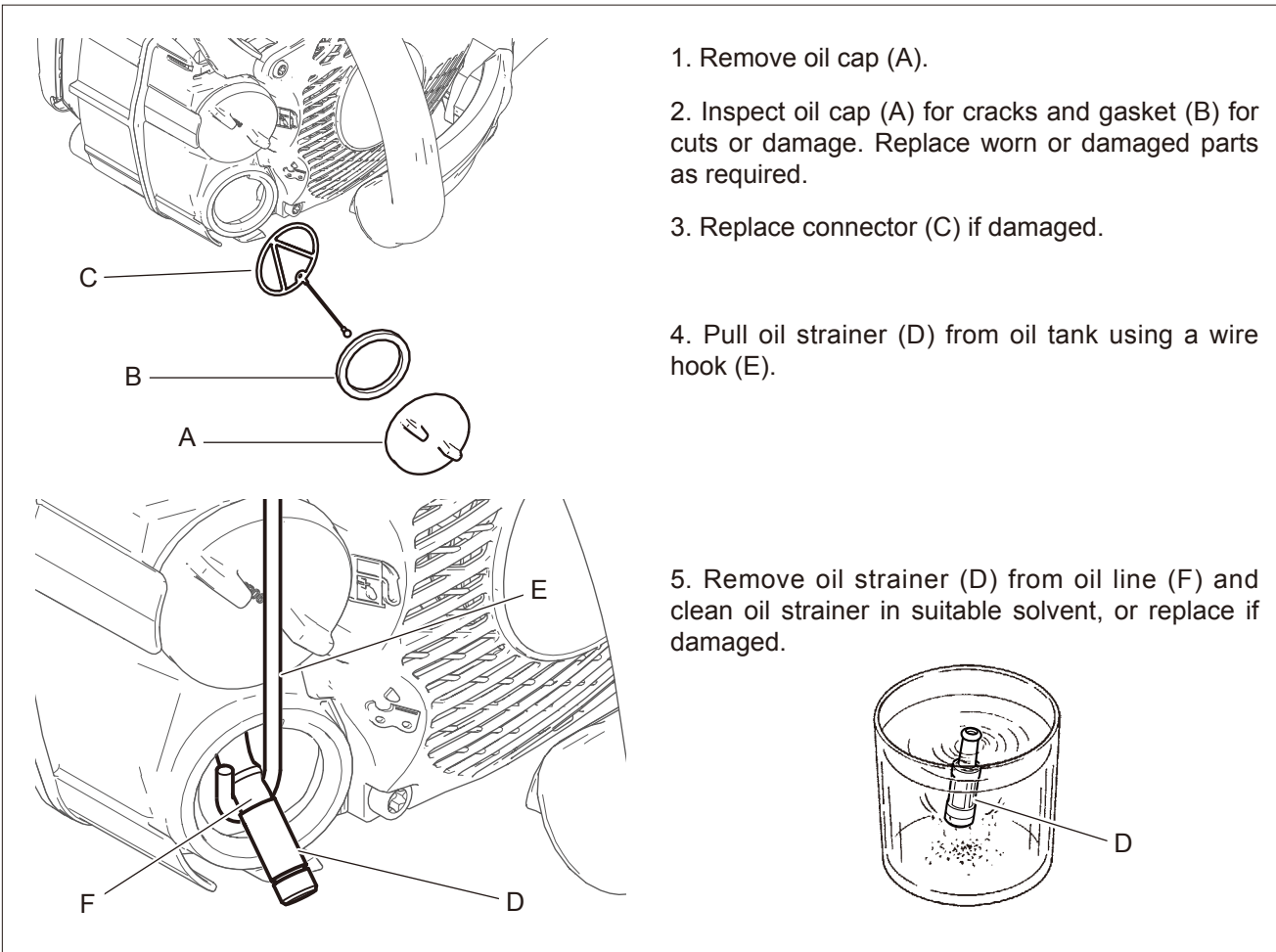

7-2 Inspecting oil tank vent

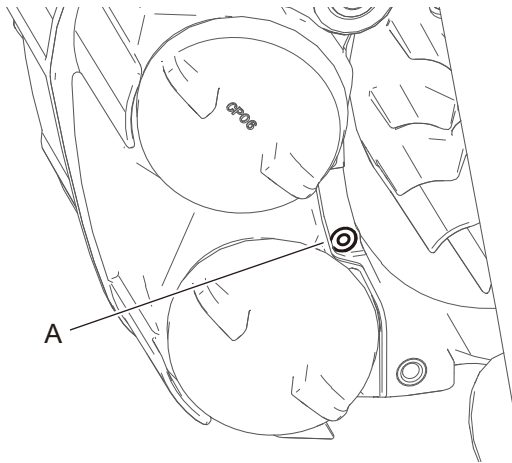

NOTE: Oil tank vent prevents a vacuum from forming in oil tank when chain oil in the tank is consumed.

1. Remove starter assembly.
2. Push oil tank vent (A) into oil tank using suitable tool and take out vent (A) from oil tank.
3. Clean oil tank vent (A).

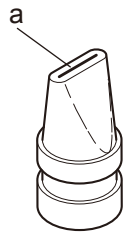

4. Check that oil tank vent lips (a) are not hard or deformed. Replace as required.

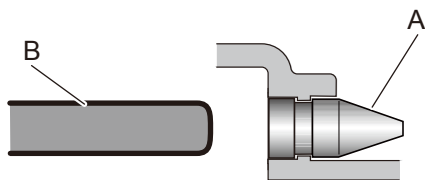

5. Install oil tank vent (A) using suitable tool (B) as shown.

6. Reassemble starter assembly.

7-3 Inspecting and replacing oil line

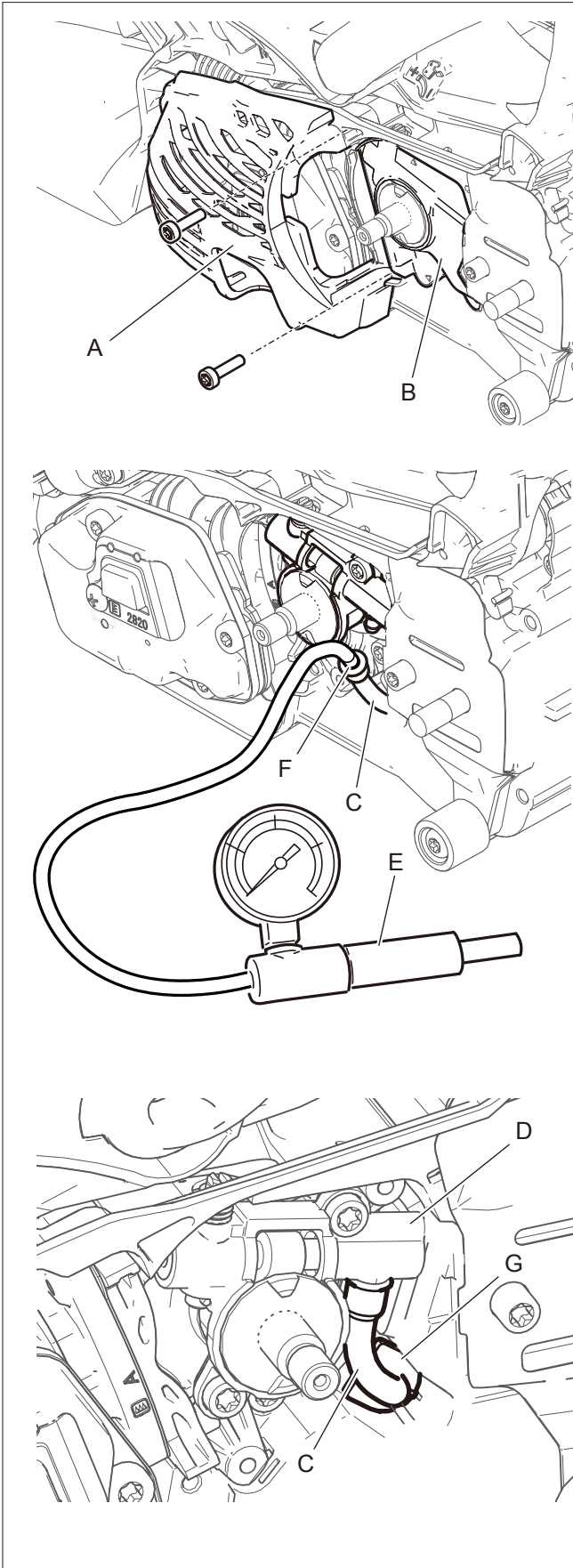
**{Inspecting and removing oil line}**

1. Remove sprocket guard, clutch assembly, clutch plate, clutch drum and needle bearing (Refer to **5-1 Inspecting clutch parts**).
2. Remove two bolts and muffler cover (A).
3. Remove oiler cover (B).
4. Disconnect oil line (C) from auto-oiler assembly (D).

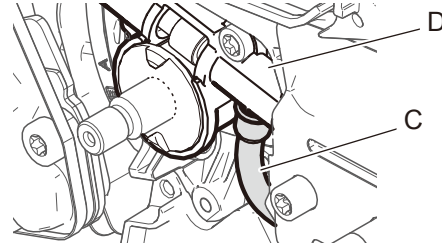

5. Connect pressure tester 897803-30133 (E) to oil line (C).

NOTE: To connect pressure tester to oil line (C), it is recommended to use pipe joint V186-000020 (F).

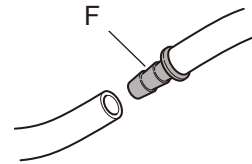

6. Tighten oil cap and apply pressure approx. 9.8 kPa (0.1kgf/cm²) (1.4psi).

7. Pressure should not drop. If the pressure drops, leakage may occur at oil line, oil cap, oil cap gasket, oil tank vent, or oil tank. Inspect them and replace defective part(s) with new part(s) as required.

NOTE: Remove oil strainer from oil line (C), before removing oil line (C). (Refer to **7-1 Inspecting oil cap and strainer**)

{Installing oil line}

8. Install oil line (C) to oil tank and connect oil line (C) to auto-oiler assembly (D) as shown.

NOTE: Make sure that grommet (G) is set in engine cover as shown.

9. Reassemble removed parts.

7-4 Inspecting worm gear

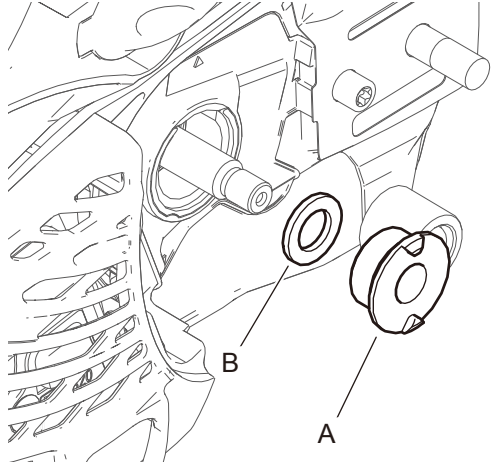

1. Remove sprocket guard, clutch assembly, clutch plate, clutch drum and needle bearing (Refer to **5-1 Inspecting clutch parts**).
2. Remove worm gear (A) and circular washer (B).
3. Inspect worm gear (A) and circular washer (B) for damage, wear or deformation. Replace with new part(s) as required.

NOTE: If worm gear (A) is damaged, inspect gear of auto-oiler assembly (Refer to **7-5 Cleaning and replacing auto-oiler assembly**).

4. Apply lithium-based grease to circular washer (B) and worm gear (A). Reinstall them.
5. Reassemble removed parts (Refer to **5-3 Installing clutch assembly**).

7-5 Cleaning and replacing auto-oiler assembly

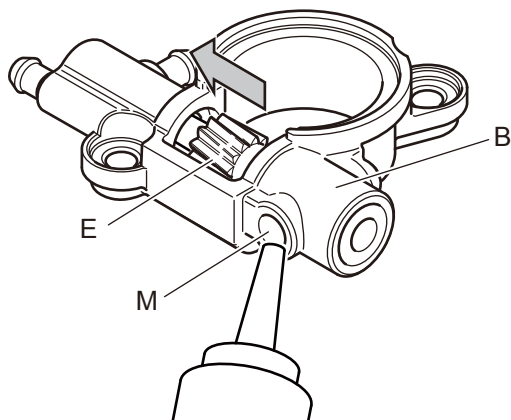
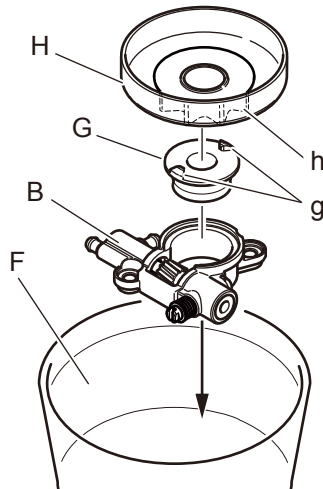
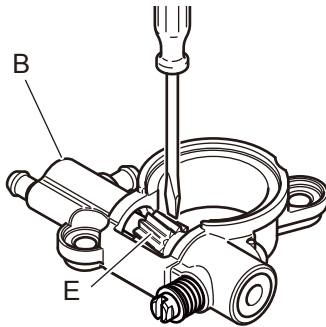
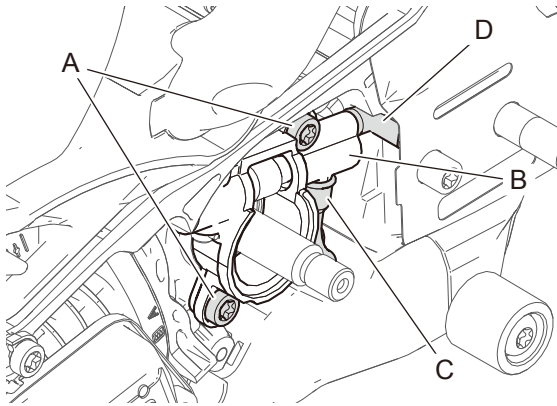
**{Cleaning and disassembling}**

1. Remove sprocket guard, clutch assembly, clutch plate, clutch drum and needle bearing (Refer to **5-1 Inspecting clutch parts**).
2. Remove muffler cover, oiler cover, worm gear and circular washer (Refer to **7-4 Inspecting worm gear**).
3. Remove two bolts (A).
4. Remove auto-oiler (B) from oil line (C) and (D).
5. Inspect if plunger gear (E) of auto-oiler (B) is rotated or not, using small flat blade driver or equivalent.
6. When plunger gear (E) can be rotated even though it is not smooth, go to step 7. When plunger gear (E) can not be rotated, go to step 14.

7. Prepare ethanol (F) in container.

8. Install new worm gear (G) to auto-oiler (B). Set clutch drum (H) on worm gear (G) engaging sprocket (h) with two protrusions (g) of worm gear (G).

9. Dip auto-oiler (B) in the ethanol (F) in container and rotate clutch drum (H) until plunger gear (E) rotates smoothly.

10. Pull out spring pin (J) from adjust needle (K) with plier and pull out adjuster needle (K) and spring (L) from auto-oiler body.

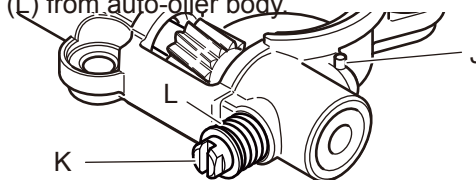

11. Hold plunger gear (E) to direction of arrow with finger. And apply grease in plunger hole (M).

12. Insert adjuster needle (K) with spring (L), holding plunger gear (E) to direction of arrow with finger. Reassemble adjuster needle (K) and spring pin as step 28 and 29.

13. Reassemble auto-oiler assembly (B) on the unit as step 31 and 32.

7-5 Cleaning and replacing auto-oiler assembly (continued)

14. When plunger gear (E) cannot be rotated, apply nail-polish remover (N) to plunger gear (E) on auto-oiler (B) and leave it a few minutes.

15. Tap 5-mm (M5 - Pitch 0.8mm) thread in the hole of plug (P).

16. Screw the bolt (Q) of puller Y089-000111 into the hole of plug (P), and connect PTO shaft puller P021-044871 (R) as shown.

17. Hold auto-oiler body by one hand. Hold puller shaft end (r1) by another hand. Hold auto-oiler body upper side and shake the weight (r2) up and down several times to remove the plug (K).

18. Pull out spring pin (J) from adjuster needle (K) with plier.

19. Pull out adjuster needle (K) and spring (L) from auto-oiler body.

20. Remove plunger gear (E), circular washer (R), spring (S) and circular washer (T). Circular washer (R) and (T) are not always come out, because of stuck by chain oil.

21. Clean plunger gear (E), oiler body, oil channels and the other parts using cotton-tipped stick with ethanol or nail-polish remover.

22. Check plunger gear (E) if worn or broken, and spring (S) if fatigued or broken. Replace parts with new one if defective.

{Assembling}

23. Coat plunger gear (E) with 2 stroke oil.

24. Insert circular washer (R) and spring (S) into plunger gear (E).

25. Insert circular washer (T) and plunger gear (E) (with spring (S) and circular washer (R)) into cylinder of auto-oiler body.

7-5 Cleaning and replacing auto-oiler assembly (continued)

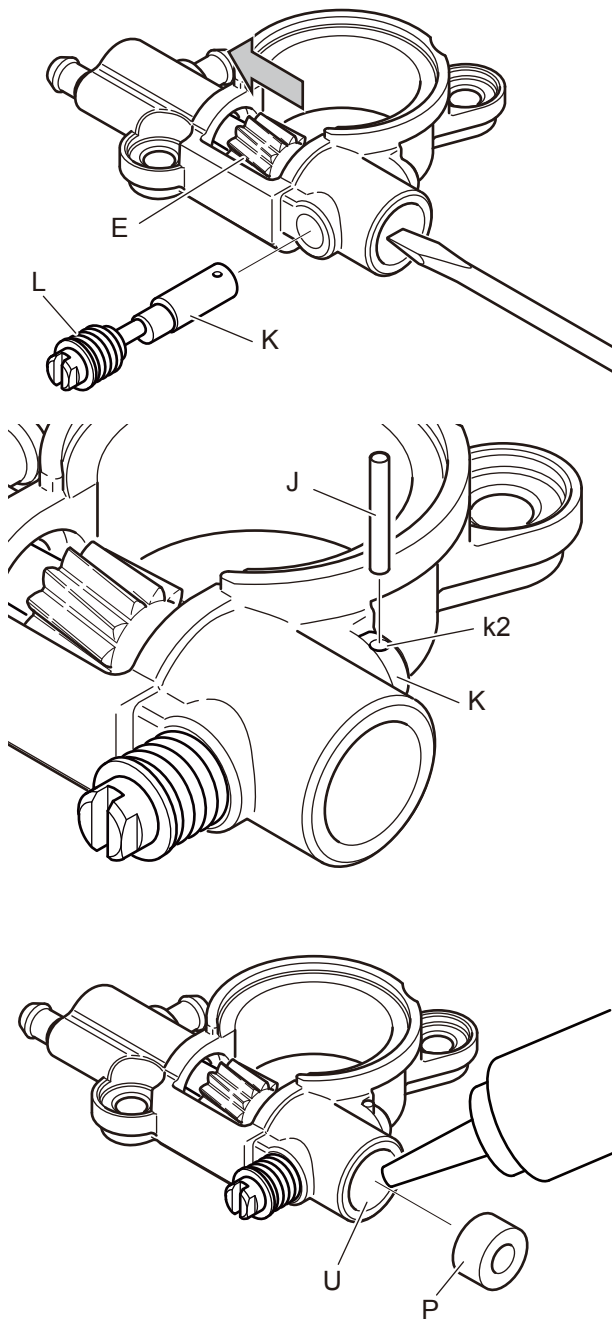

26. Push in plunger gear (E) with small screwdriver, and hold plunger gear (E) to direction of arrow with finger. Remove screwdriver.

27. Install adjuster needle (K) with spring (L) into oiler body. Release finger from plunger gear (E).

28. Press adjuster needle (K) to the bottom, orienting the flat surface (k1) as shown. This position indicates maximum discharge volume of chain oil.

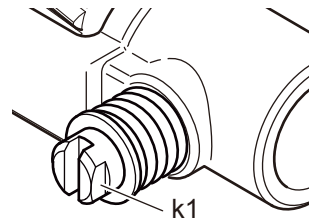

29. Tap new spring pin (J) into hole (k2) of adjuster needle (K).

30. Apply grease in plunger hole (U). Tap plug (P) into hole (U) with plastic mallet until plug (P) is flush with end face of oiler body.

31. Reinstall auto-oiler assembly (Refer to step 3 and 4).

32. Reassemble removed parts.

8 ENGINE

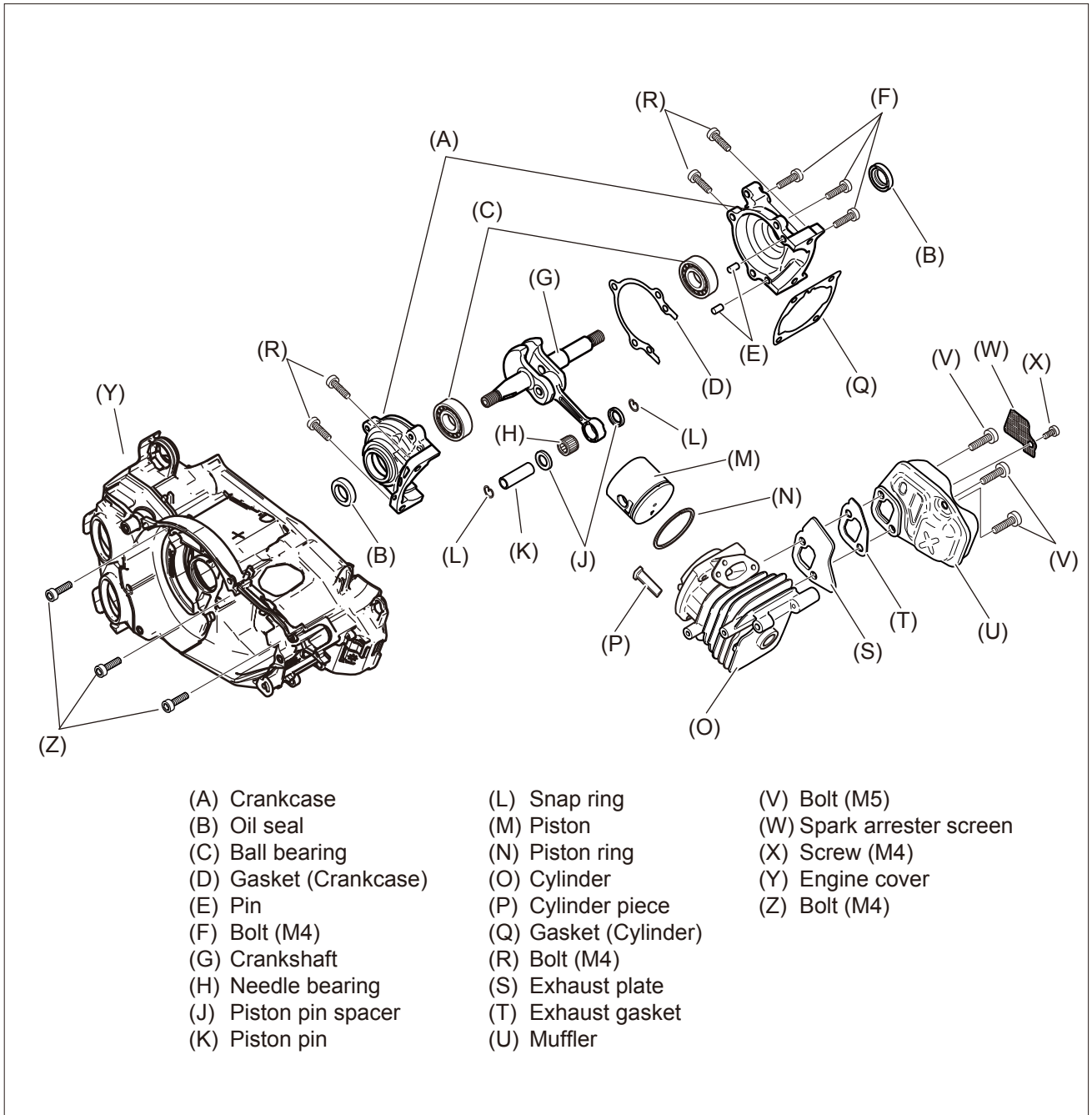

- | | | |
|------------------------|-----------------------|---------------------------|
| (A) Crankcase | (L) Snap ring | (V) Bolt (M5) |
| (B) Oil seal | (M) Piston | (W) Spark arrester screen |
| (C) Ball bearing | (N) Piston ring | (X) Screw (M4) |
| (D) Gasket (Crankcase) | (O) Cylinder | (Y) Engine cover |
| (E) Pin | (P) Cylinder piece | (Z) Bolt (M4) |
| (F) Bolt (M4) | (Q) Gasket (Cylinder) | |
| (G) Crankshaft | (R) Bolt (M4) | |
| (H) Needle bearing | (S) Exhaust plate | |
| (J) Piston pin spacer | (T) Exhaust gasket | |
| (K) Piston pin | (U) Muffler | |

8-1 Testing cylinder compression

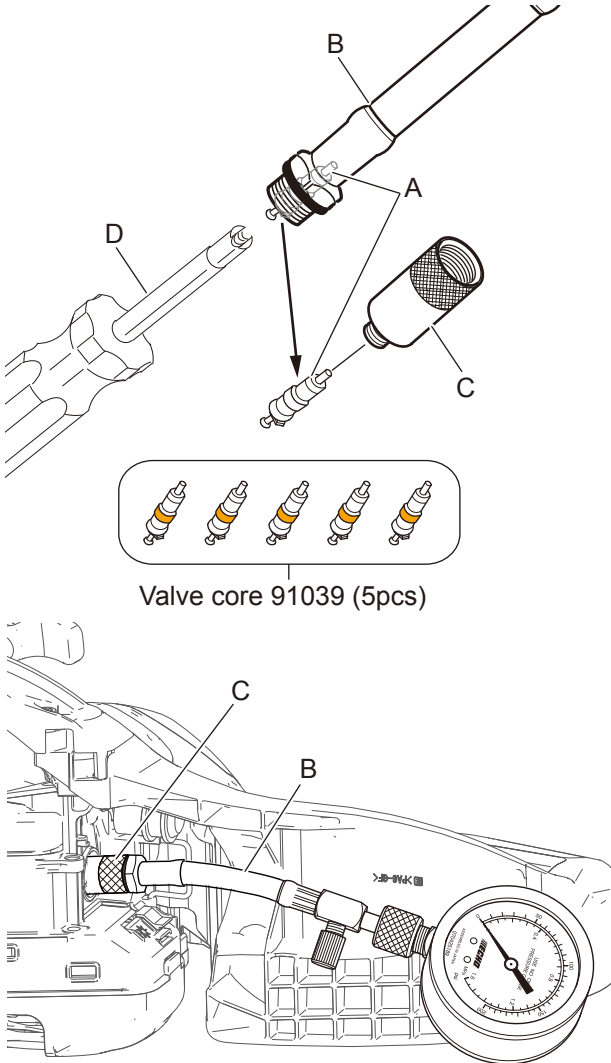

NOTE: Test cylinder compression when engine is cold.

1. Move ignition switch to STOP position.
2. Open cap cover and remove spark plug (Refer to **3-2 Testing spark**).
3. Remove valve core (A) from compression gauge 91037 (B) and insert valve core (A) to adapter X681-000000 (C) with valve core driver (D).
4. Connect adapter (C) and compression gauge (B).
5. Install compression gauge (B) with adapter (C) in spark plug hole and tighten by hand. Pull starter several times to stabilize reading on compression gauge.
6. If pressure is lower than approx. 75% of standard compression pressure (Refer to "1-2 Technical data"), inspect cylinder bore, piston and piston ring for wear or damage.
7. If pressure is more than approx. 125% of standard compression pressure, inspect cylinder combustion chamber and exhaust port, piston crown, and muffler for carbon deposits.

NOTE: Compression pressure varies with volume of compression gauge tip occupying cylinder combustion chamber. When you use other than the tool 91037 (B) and adapter X681-000000 (C), it is recommended to measure and note compression pressure of brand-new engines as standard pressure in advance.

8-2 Cleaning cooling air passages



1. Remove starter assembly (A) and fan cover (B).
2. Inspect starter assembly (A) and fan cover (B) for blockage with dirt and/or saw dust. Clean them with wooden or plastic stick or brush or compressed air as required.

WARNING  **DANGER**
Always wear eye protection when using compressed air for cleaning. Otherwise, eye damage can occur from flying particles.

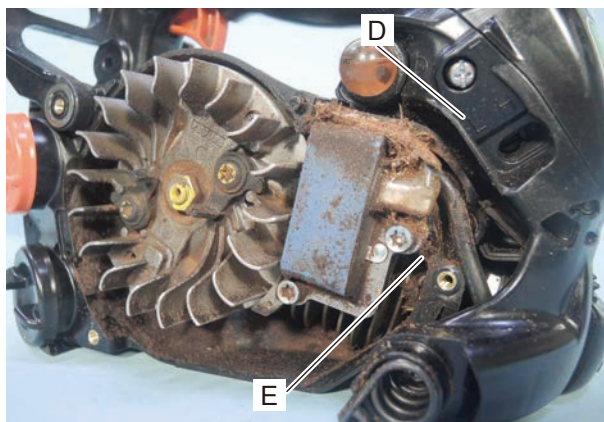

3. Inspect cylinder cooling fins (C) for blockage with dirt and/or saw dust (D). Clean them with wooden or plastic stick or compressed air as required.

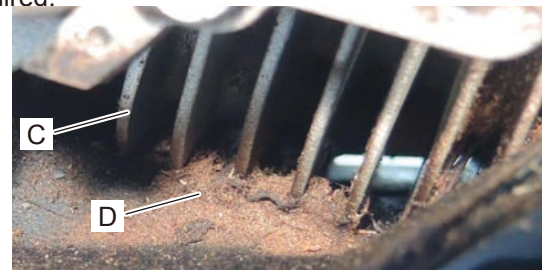

4. Remove ignition coil (E) if cylinder fins are hard to clean. Inspect the clearance of cylinder fins and the clearance between cylinder and engine cover. Clean the clearance using wooden stick or plastic stick or compressed air if dust is found.

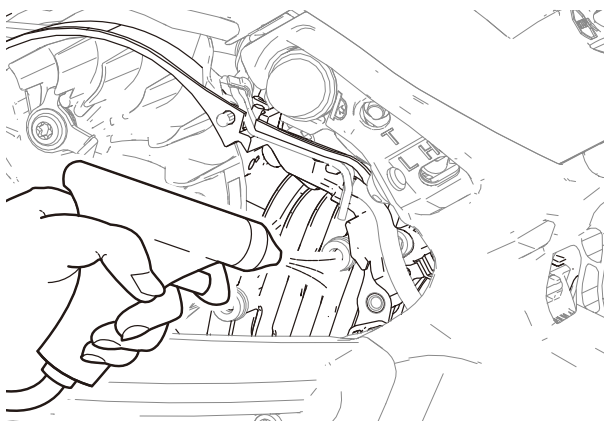

5. Remove muffler cover, muffler, exhaust gasket and exhaust plate from cylinder (Refer to "8-3 Inspecting muffler and exhaust port").

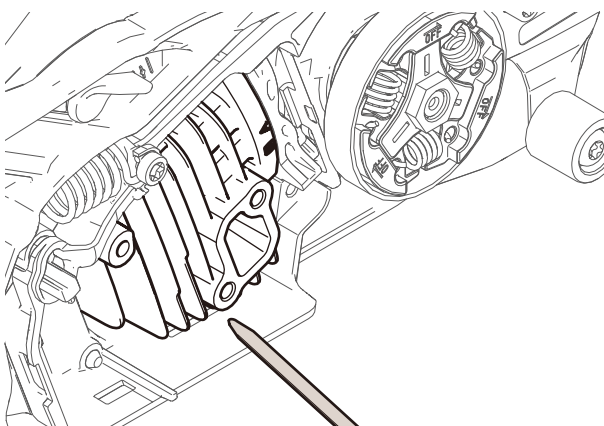

6. Inspect the clearance of cylinder fins and the clearance between cylinder and engine cover. Clean the clearance using wooden stick or plastic stick or compressed air if dust is found.

8-3 Inspecting muffler and exhaust port

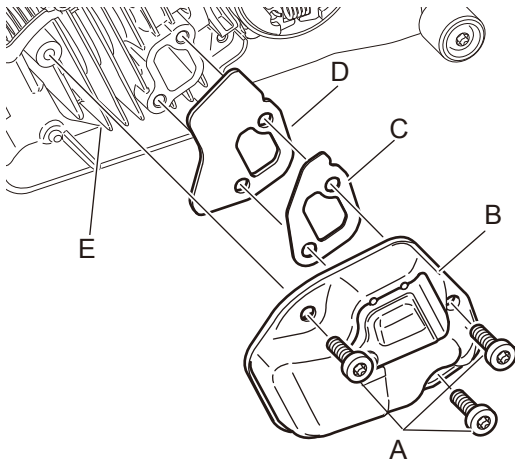

1. Remove sprocket guard and muffler cover.
2. Remove three bolts (A), muffler (B), exhaust gasket (C) and exhaust plate (D) from cylinder (E)

NOTE : If exhaust gasket (C) stays on muffler (B), keep them as it is to reuse.

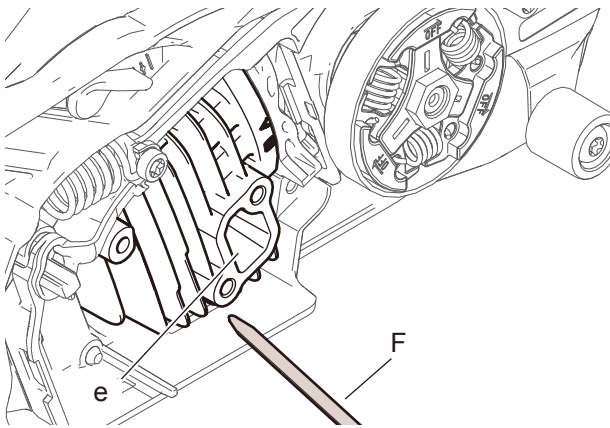

3. Inspect cylinder exhaust port (e) and clean the port using wooden or plastic stick (F) if carbon is found.

NOTE: When cleaning exhaust port, always position piston at Top Dead Center (TDC) to prevent carbon from entering cylinder. Do not use metal tool, and be careful not to scratch piston or cylinder.

NOTE: Replace muffler gasket with new one when damaged or removing from muffler.

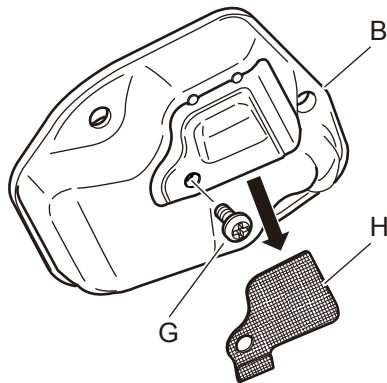

4. Remove screw (G) and pull spark arrester screen (H) out from muffler (B).

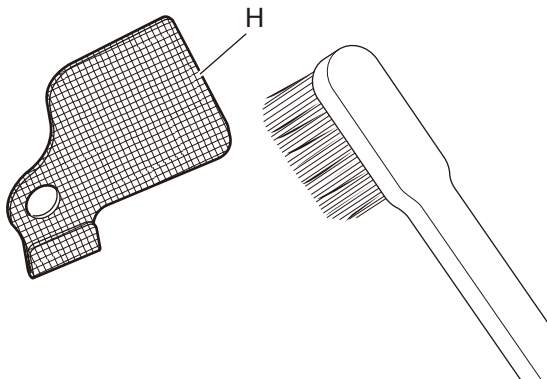

5. Remove carbon deposits from spark arrester screen (H). If screen has heavy deposits, replace with new one.

6. Reassemble spark arrester screen (H) and tighten screw (G).

8-4 Testing crankcase and cylinder sealings

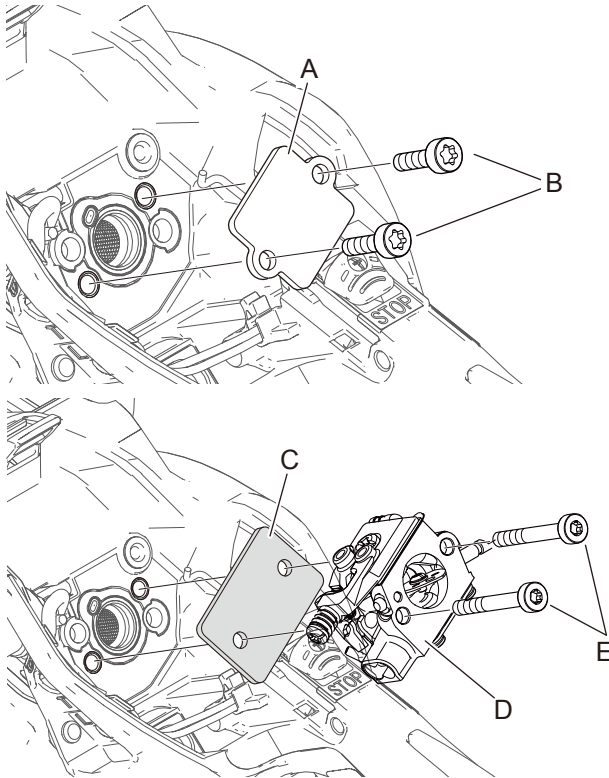

1. Remove air cleaner cover, air filter and carburetor from the unit (Refer to **4-9 Testing carburetor**).

2. There are two ways to seal intake port and crankcase pulse passage. Choose convenient one from followings.

Way1 : Install pressure plate 897827-16131 (A) and tighten M5 bolts (B) of 8-10 mm (0.3-0.4 in) length.

Way2 : Install pressure rubber plug 897826-16131 (C) and carburetor (D) and tighten original bolts (E) for carburetor.

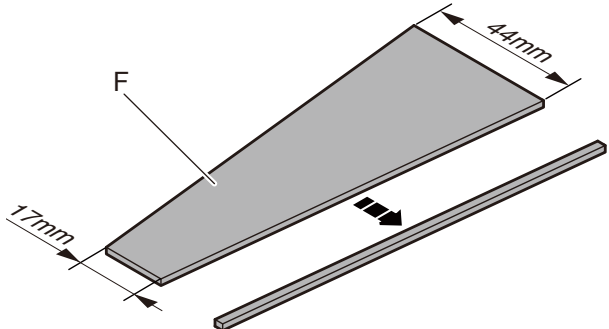

3. To seal exhaust port of cylinder, cut pressure rubber plug 91041 (F) off as shown.

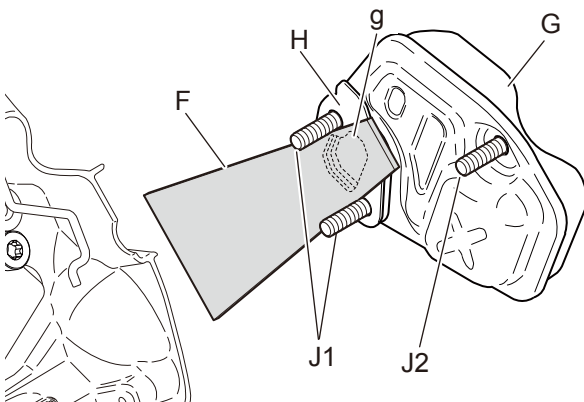

4. Remove exhaust plate and muffler (G) with exhaust gasket (H) (Refer to **8-3 Inspecting muffler and exhaust port**).

5. Set pressure rubber plug (F) to muffler (G) with exhaust gasket (H) as shown.

NOTE : Make sure to cover exhaust port (g) of muffler with pressure rubber plug (F).

6. Gently tighten muffler bolts (J1 and J2) until the muffler (G) and pressure rubber plug (F) fit with cylinder. Then turn muffler bolts (J1) 180 degrees clockwise.

NOTE : Do not install exhaust plate. Do not tighten muffler (G) and pressure rubber plug (F) fully, or muffler (G) may be deformed.

8-4 Testing crankcase and cylinder sealings (continued)

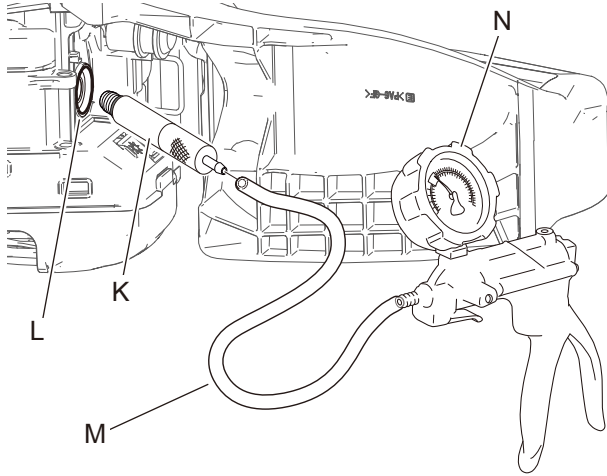

7. Open cap cover and remove spark plug.
8. Install pressure connector A131-000160 (K) to spark plug hole (L).
9. Connect suitable pipe (inner dia. 4mm) (M) between pressure connector (K) and pressure/vacuum tester 91149 (N) as shown.
10. Apply pressure approx. 50 kPa (0.5 kgf/cm²) (7.3 psi) by pressure/vacuum tester 91149 (N) and leave for 30 seconds.
11. If the reading drops, leakage may occur.
12. Leakage may occur from crankcase seam or oil seal. Use soapy water to locate leakage.
13. Then, apply negative pressure approx. 30 kPa (0.3 kgf/cm²) (4.4 psi) by pressure/vacuum tester 91149 (N) and leave for 30 seconds.
14. If the reading drops, leakage may occur from oil seal. Inspect oil seal for damage or wear.
15. Remove plate and plug (or plugs) from exhaust port and intakeport after this inspection, and reinstall all the removed parts.

8-5 Removing engine block

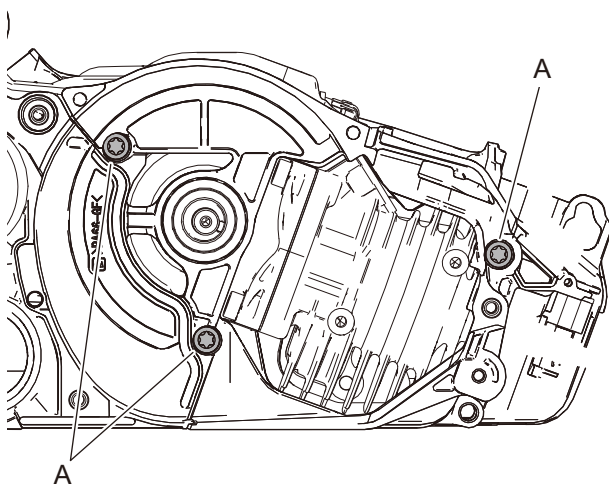

1. Remove rear handle from the unit (Refer to **9-3 Replacing rear handle and springs**).
2. Remove spark plug, clutch parts, oiler cover, worm gear, circular washer, auto-oiler assembly, ignition coil and flywheel .
3. Remove three bolts (A) from engine cover.

8-5 Removing engine block (continued)

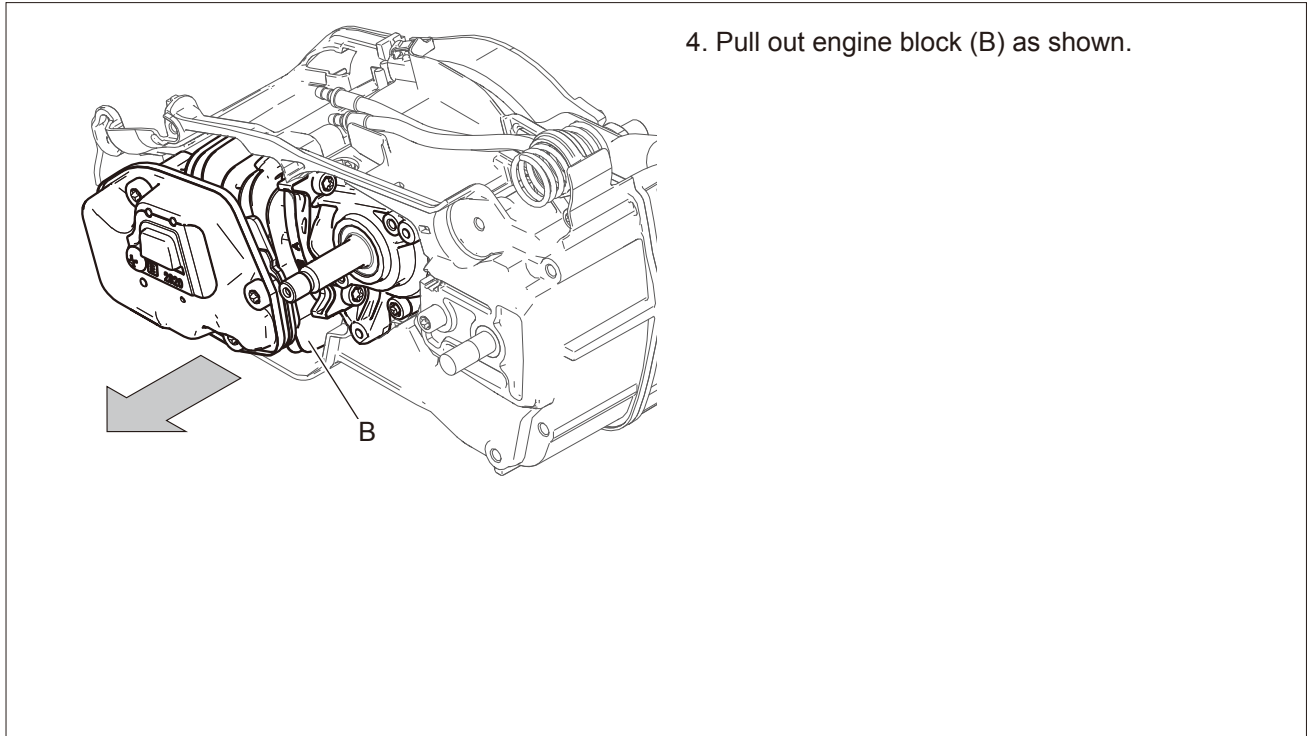

8-6 Inspecting cylinder

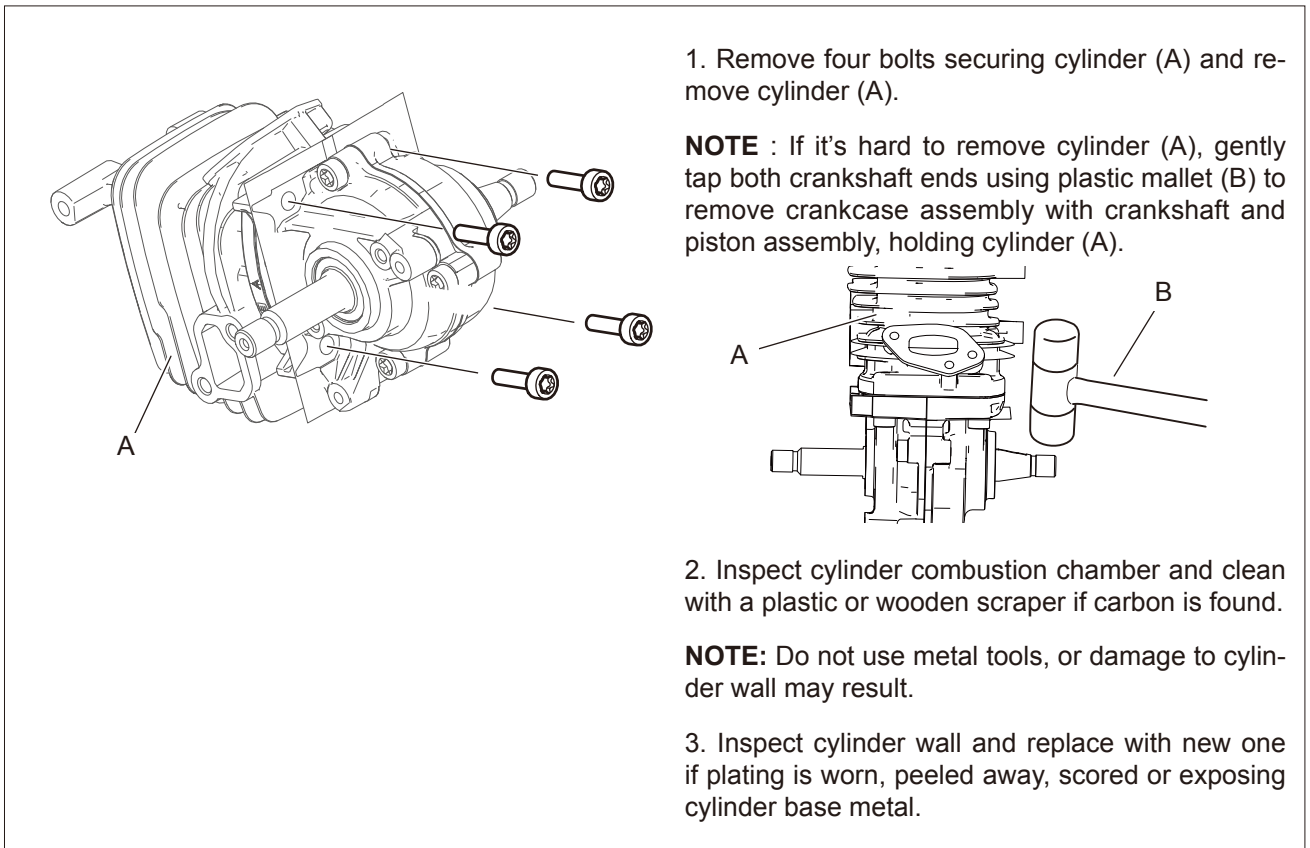

8-7 Inspecting piston and piston ring

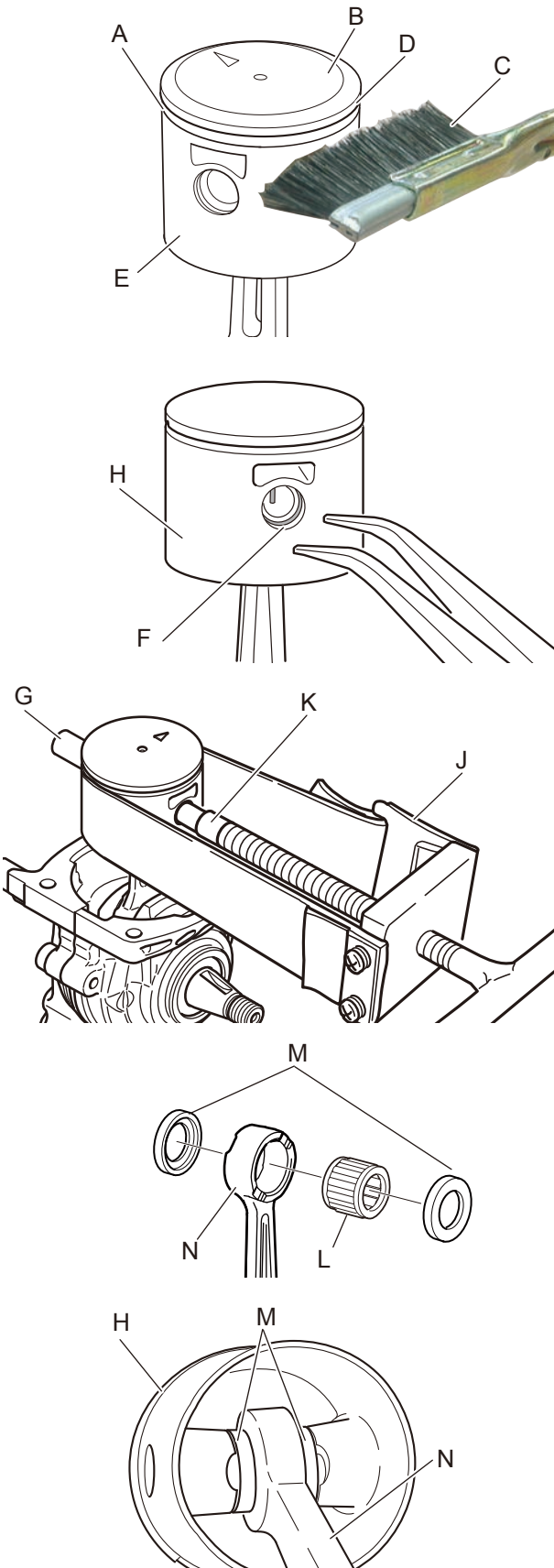

{Disassembling}

1. Inspect piston ring (A) and replace it if broken, scored, or exceeded service limits (Refer to **1-5 Service limits**).
2. Inspect piston crown (B). Clean with fine sand paper, oil stone, and soft cleaning brush (C) if carbon is found.
3. Inspect top land (D), ring groove and skirt (E). Clean them with soft cleaning brush (C), if carbon is found.

NOTE: Do not use square end of broken piston ring when cleaning piston ring groove, otherwise piston ring groove might be damaged.

4. Remove snap rings (F) from both sides of piston pin.
5. Push piston pin (G) out from piston (H).

NOTE: If piston pin is tight, use piston pin tool 897702-30131 (J) with adapter (K) stamped "8" on an end.

6. Inspect piston pin, needle bearing and piston pin spacers, and replace if wear or discoloration is noted.

{Assembling}

7. Lubricate needle bearing (L) with 2-stroke oil.
8. Set needle bearing (L) and piston pin spacers (M) on small end of connecting rod (N).
9. Place piston (H) over connecting rod (N).

8-7 Inspecting piston and piston ring (continued)

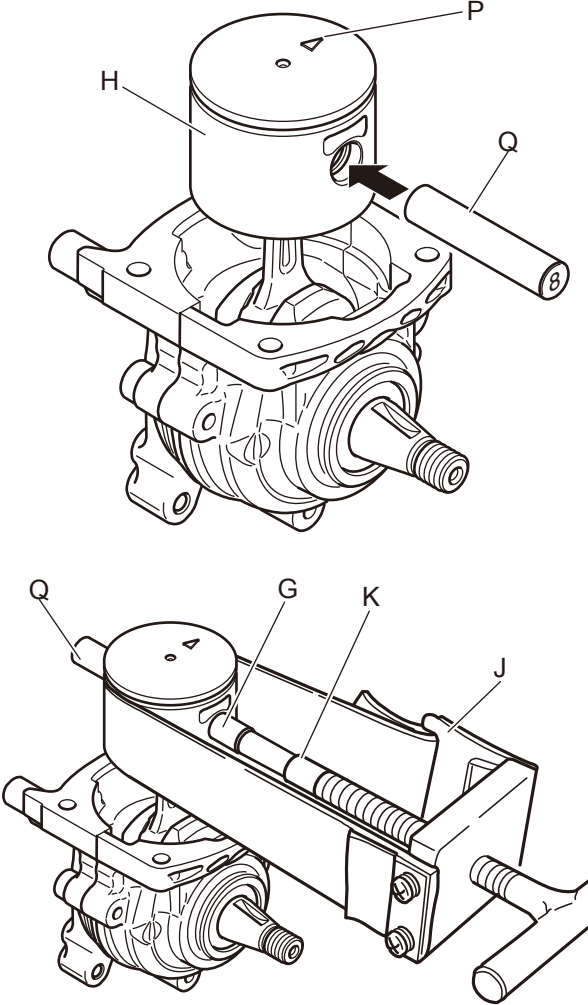

NOTE: Make sure to place piston with piston arrow mark (P) pointing as shown.

10. Insert pin guide tool (Q) stamped “8”, through piston (H), with needle bearing (L) and piston pin spacers (M) set at step 9.

11. Insert piston pin (G) in piston (H), pushing out pin guide tool (Q) until the pin end comes up to snap ring groove.

NOTE: If piston pin is tight, use piston pin tool 897702-30131 (J) with pusher adapter (K) stamped “8”.

12. Install new snap rings on both end of piston pin. Make sure that they are properly seated in snap ring grooves.

NOTE: Always use new snap rings.

13. Install piston ring on piston.

8-8 Replacing oil seal

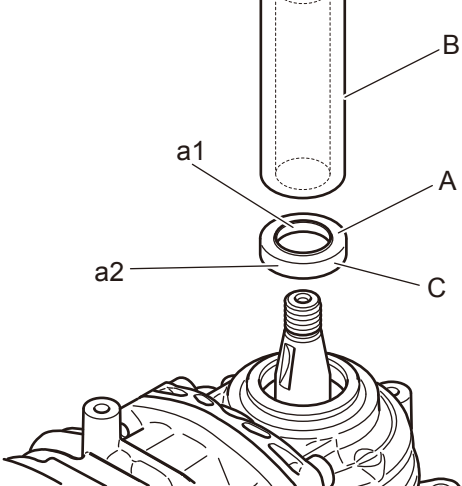

1. Pry defective oil seal from crankcase.

NOTE: Be careful not to damage crankshaft and oil seal housing.

NOTE: Before removing flywheel side oil seal, remove woodruff key.

2. Apply lithium based grease on inner rubber lips (a1) of new oil seal (A).

3. Lubricate circumferences (a2) of new oil seal with 2-stroke oil.

4. Push in new oil seal (A) until flush with crankcase surface using oil seal tool 897726-09130 (B).

8-9 Inspecting crankcase and crankshaft

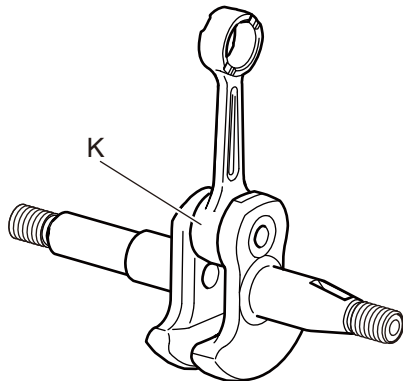
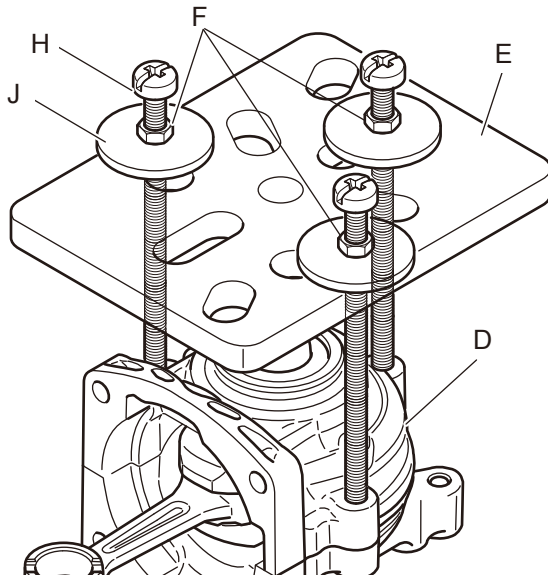
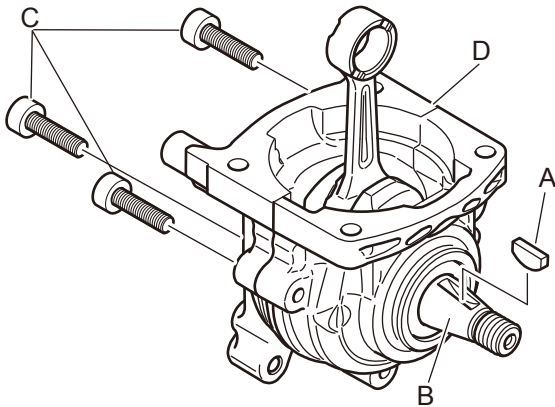

1. Remove cylinder, gasket and piston.
2. Remove woodruff key (A) from crankshaft fly-wheel end (B).
3. Remove three bolts (C) from crankcase assembly (D).

4. Set puller Y089-000111 (E) on crankcase assembly (D) as shown.
5. Tighten three nuts (F) on the puller (E) alternately to remove crankcase.
6. Remove another crankcase half in the same ways.

NOTE : If puller Y089-000111 (E) is not available, you can use puller Y089-000110 (G) prepared as follows.

- (1) Drill two 6mm dia holes on puller Y089-000110 (G) as below.
- (2) Three screws or bolts 91311-04075 (H) (size: M4x75mm length, pitch 0.7mm)
- (3) Three nuts 900500-00004 (F) (size : M4, pitch 0.7mm)
- (4) Three circular washers 177214-03930 (J) (size : inner dia.4.5 x outer dia.16.5 x 1.0mm thickness)

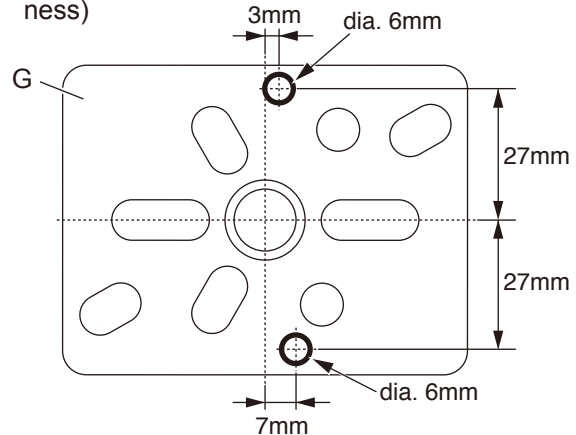

7. Clean the inside of crankcase. Replace with new one if damaged.

8. Measure crankshaft runout and replace if it exceeds service limits (Refer to **1-5 Service limits**). Inspect connecting rod big end (K) for discoloration or needle bearing damage. Replace crankshaft assembly with new one as required.

8-10 Replacing oil seal and ball bearing

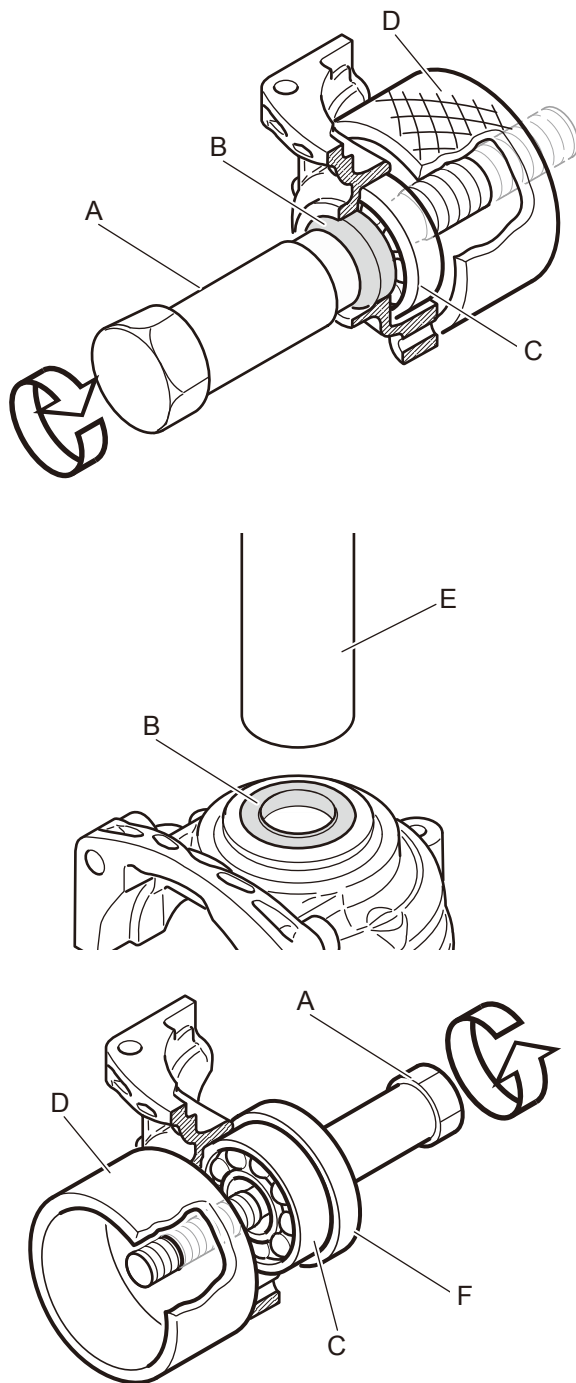

{Disassembling}

1. After disassembling crankshaft, check ball bearing for smooth rotation. If rough, replace it (them) with new one.

NOTE: At the same time, replace oil seal with new one.

2. Remove ball bearing (C) from crankcase half using bearing tool 897701-14732 as follows.

3. Set shaft (A) through oil seal (B) and ball bearing (C) with boss (D) as shown.

4. Tighten shaft (A) with wrench to remove ball bearing (C). Oil seal (B) remains in crankcase bore.

5. Push out oil seal (B) with using oil seal tool 897726-09130 (E)

{Assembling}

6. Set new ball bearing (C) with shaft (A), adapter (F) (inner dia. 15 mm, outer dia. 40 mm) and boss (D).

NOTE: Set adapter (F) mating full flat side to ball bearing.

7. Tighten shaft (A) with wrench to press ball bearing into the crankcase half until flush.

8. Check that bearing rotates smoothly.

9. Apply lithium based grease on inner rubber lips of new oil seal (A).

10. Lubricate circumferences of new oil seal with 2-stroke oil.

11. Push in new oil seal (B) until flush with crankcase surface using oil seal tool 897726-09130 (E).

8-11 Assembling crankshaft and crankcase

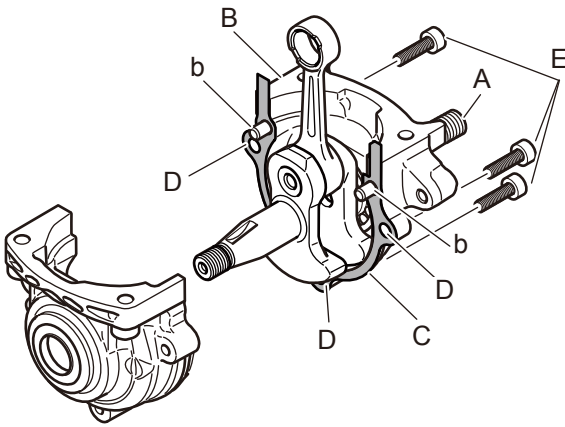

1. Clean mating surface of each crankcase half.

2. Heat ball bearing for easier installation. Then insert crankshaft clutch end (A) into clutch side crankcase half (B) until properly seated.

WARNING  **DANGER**

When using a heat gun, wear gloves. Otherwise, a burn will result.

3. Put new crankcase gasket (C) on clutch side crankcase half (B).

NOTE: Make sure to match hole position (D) of crankcase gasket (C) and clutch side crankcase half (B).

4. Reassemble both crankcase halves together ensuring that dowel pins (b) on clutch side crankcase half (B) are properly seated in holes on the other half.

5. Tighten three bolts (E) diagonally to secure crankcase halves together, and check crankshaft for smooth rotation.

NOTE: If crankshaft doesn't rotate smoothly, tap both ends of crankshaft with plastic mallet several times. And recheck crankshaft for smooth rotation.

6. Carefully remove excess portion (c) of crankcase gasket (C) with sharp knife.

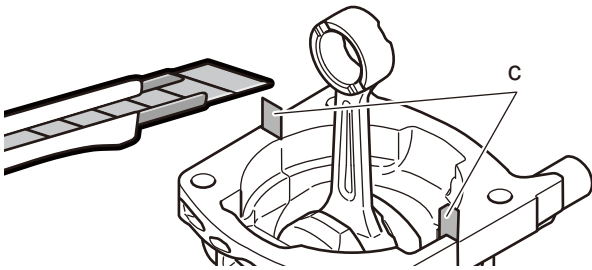

8-12 Installing piston ring and cylinder

1. Completely remove gasket residue on mating surfaces of cylinder and crankcase.
2. If cylinder piece (A) came off from cylinder (B), reinstall it (A) to starter side scavenging port (b1) of cylinder as shown.
3. Set new cylinder gasket (C) on cylinder (B), as notch (c1) of gasket (C) aligns pulse hole (b2).
4. Install piston ring (D) on piston (E), ensuring the end gaps of piston ring are properly positioned around locating pin (e1) as shown.
5. Apply oil to piston ring (D) and internal wall of cylinder (B).
6. Install piston (E) in cylinder (B) with arrow (e2) pointing as shown.
7. Fasten four bolts (F)

9 HANDLE AND CONTROL SYSTEM

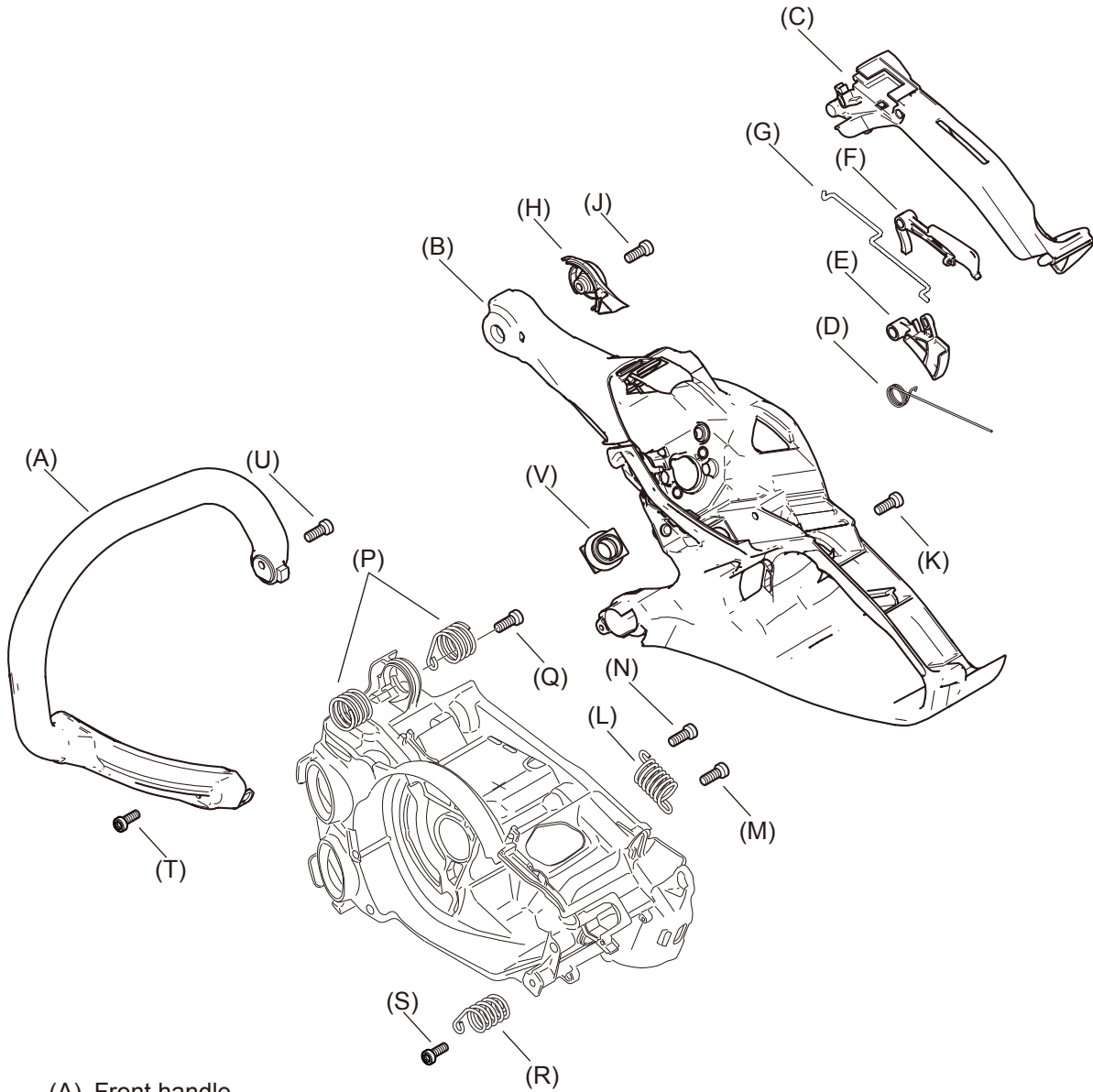

- (A) Front handle
- (B) Rear handle
- (C) Rear handle lid
- (D) Torsion spring
- (E) Throttle trigger
- (F) Throttle lockout
- (G) Throttle rod
- (H) Spring holder
- (J) Bolt (M4)
- (K) Bolt (M4)
- (L) Spring
- (M) Bolt (M4)
- (N) Bolt (M4)
- (P) Spring
- (Q) Bolt (M4)
- (R) Spring
- (S) Bolt (M4)
- (T) Bolt (M4)
- (U) Bolt (M5)
- (V) Intake pipe

9-1 Replacing throttle control parts

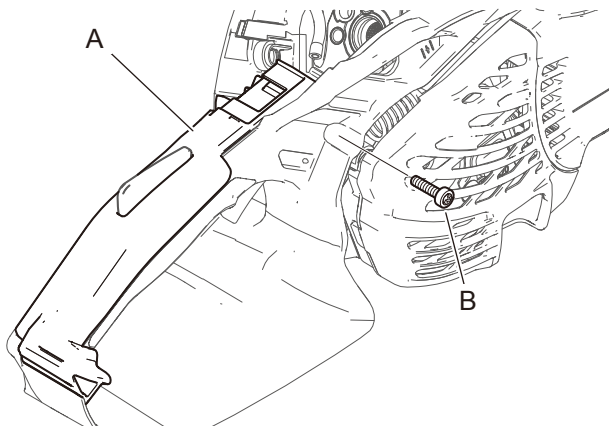

{Disassembling}

1. Remove air cleaner cover, air filter and carburetor from the unit.
2. Remove ignition switch from rear handle lid (A).
3. Remove bolt (B) and then remove throttle control parts.
4. Check throttle control parts and replace defective part(s) with new one as required.

{Assembling}

5. Insert torsion spring (D) to throttle rockout (E).
6. Assemble torsion spring (D) with throttle rockout (E) on rear handle lid (A) as shown.

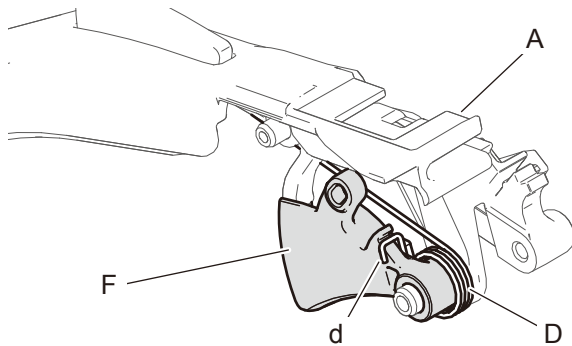
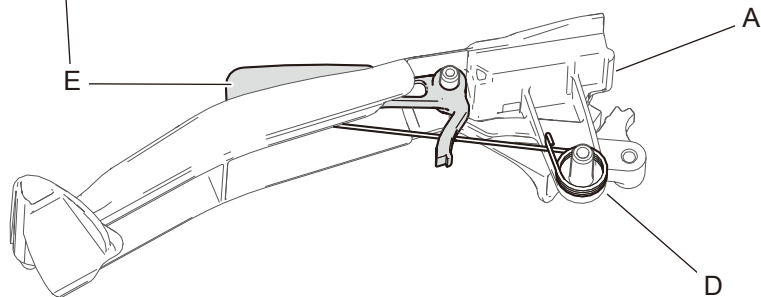
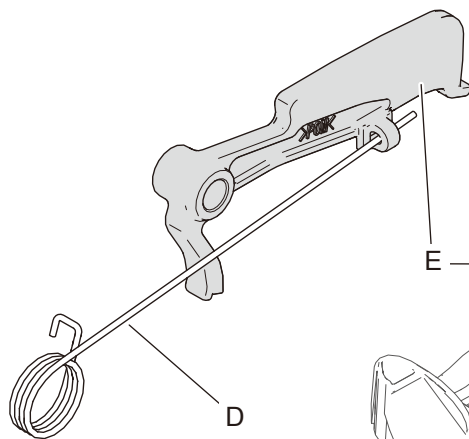

7. Assemble throttle trigger (F) on rear handle lid (A), hooking end (d) of torsion spring (D) on the trigger as shown.

8. Insert throttle rod (G) to hole (f) of throttle trigger (F).

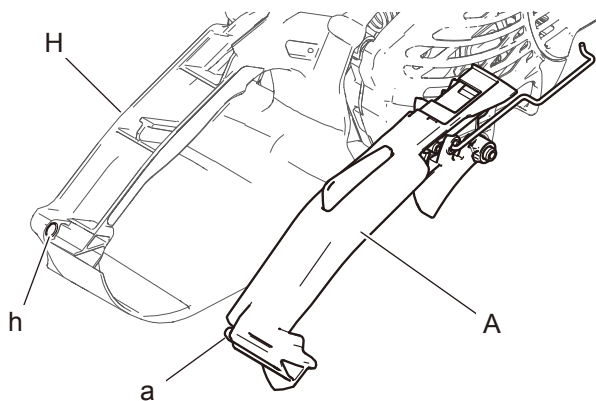
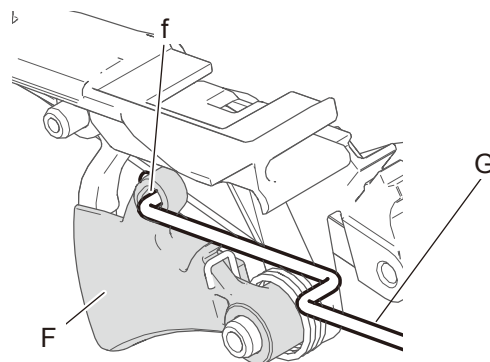

9. Assemble throttle control parts on rear handle (H), inserting boss (a) of rear handle lid (A) to hole (h) of rear handle (H) as shown.

10. Assemble removed parts.

9-2 Replacing front handle and spring

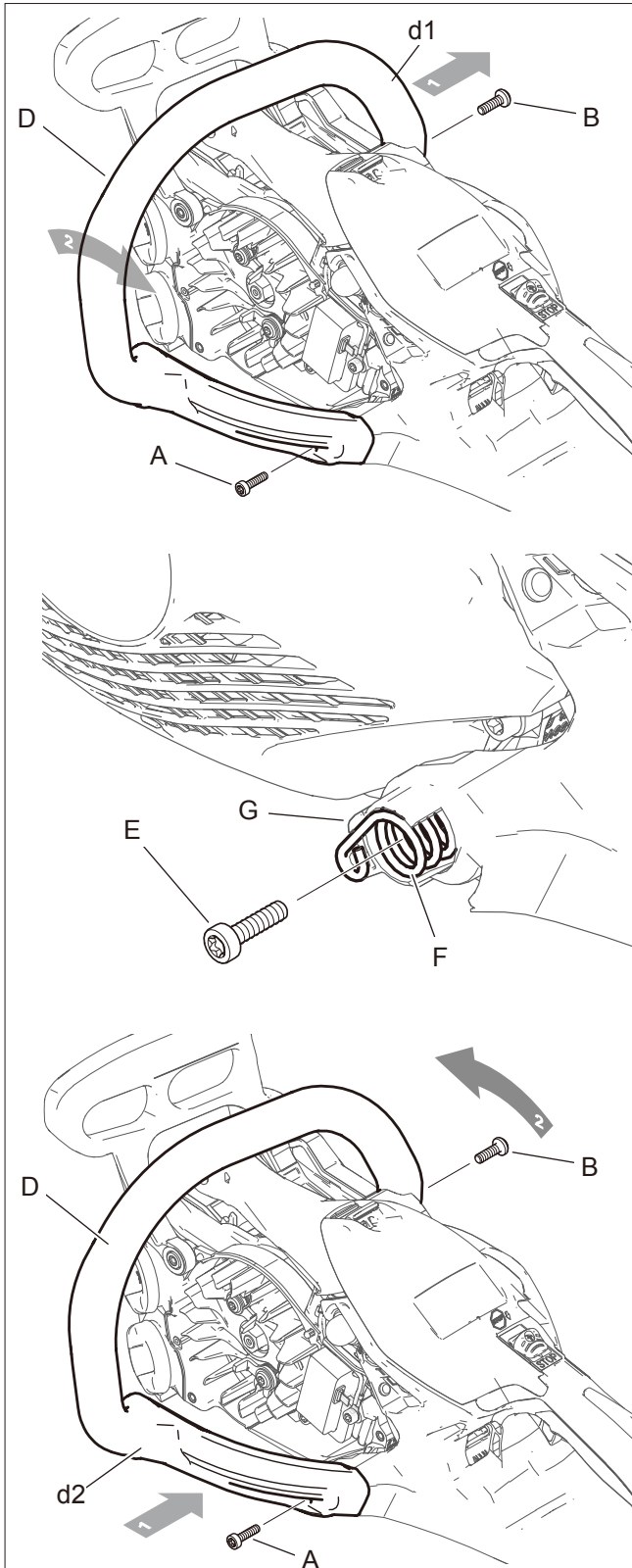
**{Disassembling}**

1. Remove bolt (A) and screw (B).
2. Remove clutch side (d1) of front handle (D) from rear handle.
3. Remove front handle (D), turning the handle as shown.

4. Remove bolt (E) and spring (F).

{Assembling}

5. Install spring (F) to rear handle and tighten bolt (E).

NOTE : Make sure to set spring (F) inside projection (G)

6. Insert magneto side (d2) of front handle (D) to rear handle.
7. Install front handle (D), turning the handle as shown.
8. Tighten bolt (A) and screw (B).
9. Assemble removed parts.

9-3 Replacing rear handle and springs

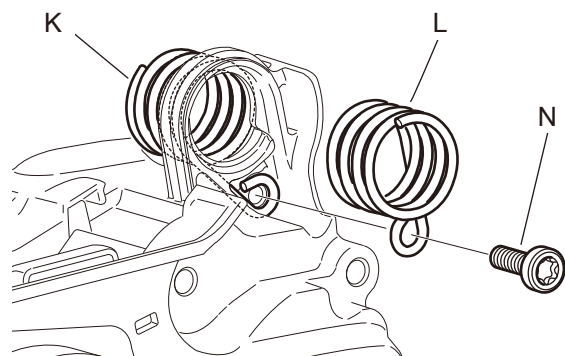
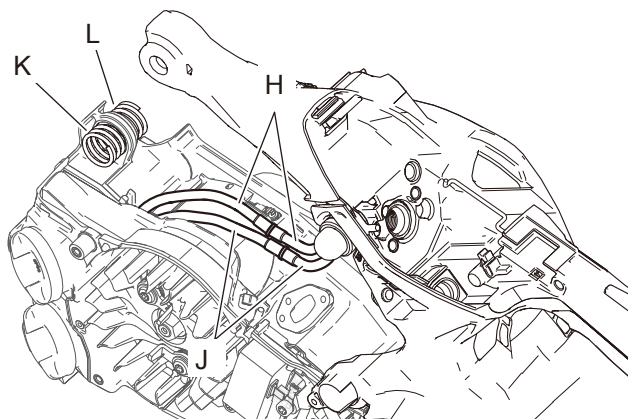
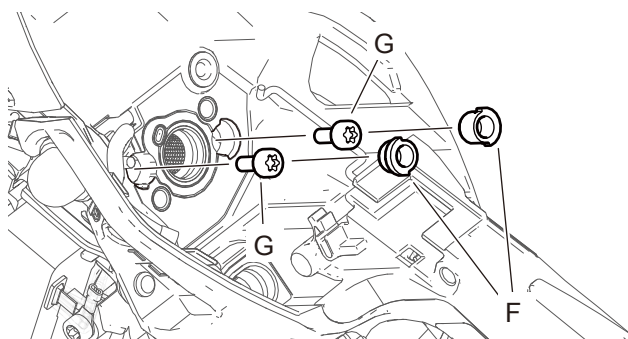
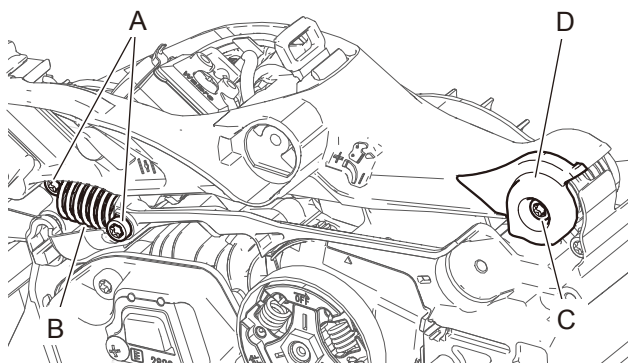

{Disassembling}

1. Remove starter assembly, air cleaner cover and air filter.
2. Remove front handle and spring (Refer to 9-2 Replacing front handle and spring).
3. Remove sprocket guard, muffler cover, chain catcher, sprocket guard plate, and brake lever (Refer to 6-1 Replacing brake lever and torsion spring)
4. Remove two bolts (A) and spring (B).
5. Remove bolt (C) and spring cover (D).
6. Check spring (B) and replace with new one as required.
7. Remove ignition switch and carburetor.
8. Remove two plugs (F) and then remove two bolts (G).
9. Disconnect fuel pipes (H) and fuel return pipes (J).

NOTE: When removing bolts (G), always position piston at Top Dead Center (TDC) to prevent dropping the bolts into the cylinder.

10. Check springs (K) and (L) and replace with new one as required.

{Assembling}

11. Install spring (K) to engine cover, inserting end (k1) of spring (K) to hole (M) of engine cover.

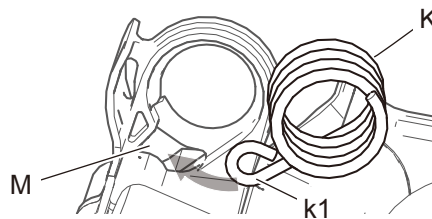

12. Install spring (L) and tighten bolt (N).
13. Connect fuel pipes (H) and fuel return pipes (J).

9-3 Replacing rear handle and springs (continued)

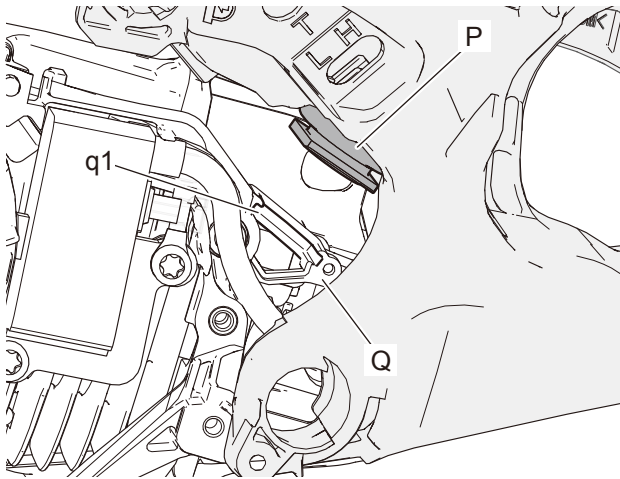

14. Install intake pipe (P) into groove (q1) of engine cover (Q) and then assemble rear handle.

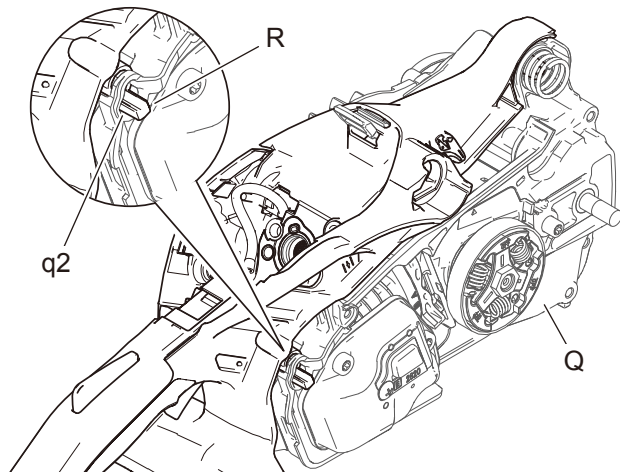

NOTE: Make sure boss (R) of rear handle insert to hole (q2) of engine cover (Q) as shown.

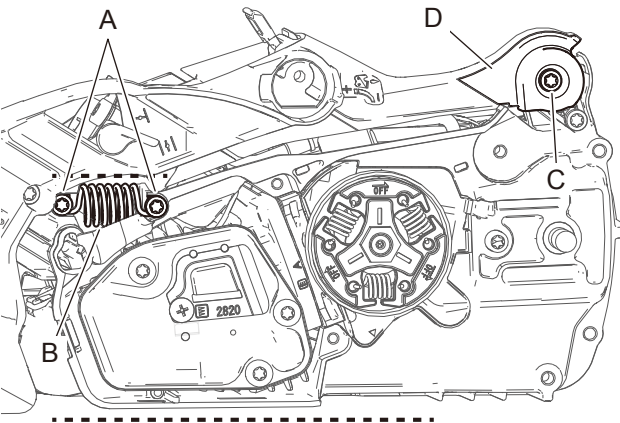

15. Install spring (B) and tighten two bolts (A).

NOTE : Make sure spring (B) is installed parallel to lower surface of the unit.

16. Install spring cover (D) and tighten bolt (C).

17. Assemble removed parts.

10 GUIDE BAR MOUNTING SYSTEM

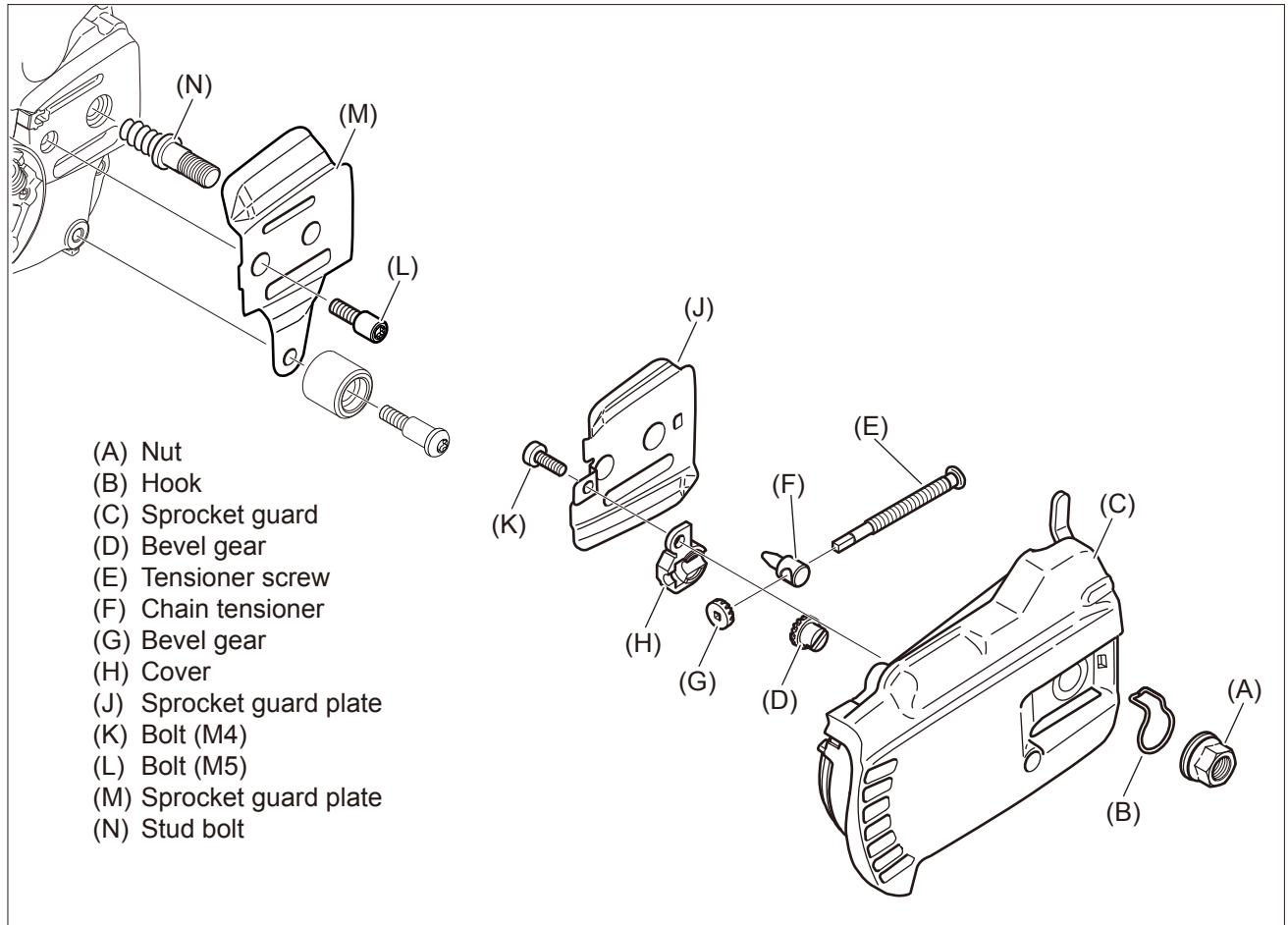

10-1 Replacing nut for fixing guide bar

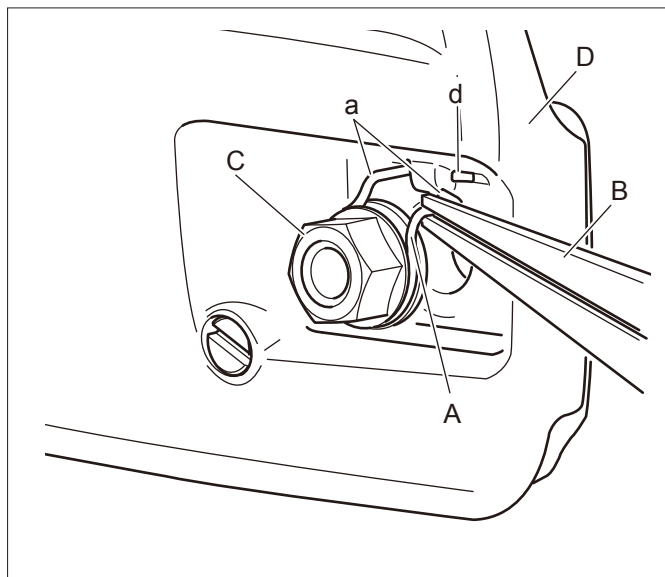

{Disassembling}

1. Pinch hook (A) with pliers (B) and remove hook (A) and nut (C) from sprocket guard (D).
2. Remove nut (C) from hook (A).
3. Check removed parts and replace defective parts with new one as required.

{Assembling}

4. Assemble nut (C) and hook (A).
5. Insert both ends (a) of hook (A) in holes (d) of sprocket guard (D).

10-2 Replacing chain tensioner

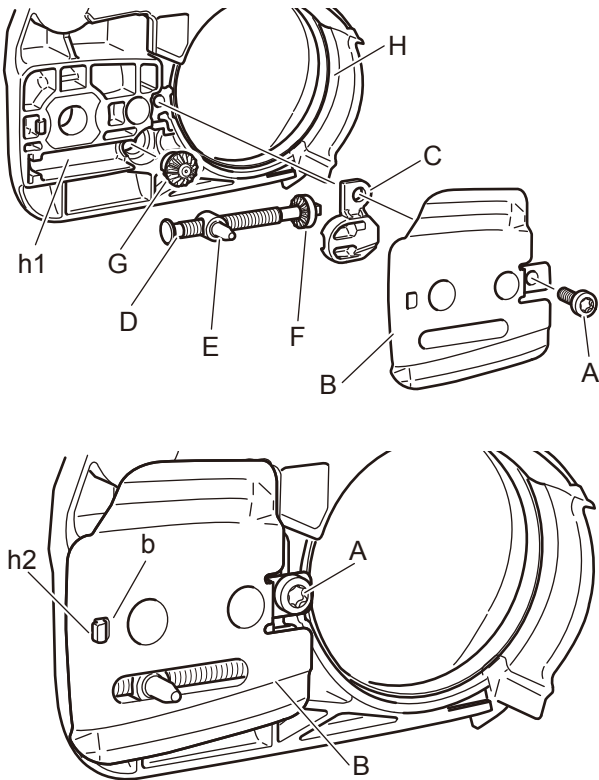
**{Disassembling}**

1. Remove bolt (A), sprocket guard plate (B), cover (C), tensioner screw (D), chain tensioner (E), bevel gear (F) and (G) from sprocket guard (H).
2. Check removed parts for damage or wear. Replace with new part(s) as required.

{Assembling}

3. Install bevel gear (G) into sprocket guard (H).
4. Screw chain tensioner (E) on tensioner screw (D).
5. Put bevel gear (F) on tensioner screw (D).
6. Install sub assembled tensioner screw in slot (h1) of sprocket guard (H) confirming engagement of bevel gear (F) and (G).
7. Reassemble cover (C) and sprocket guard plate (B). Tighten bolt (A).

NOTE : Make sure to hook tub (h2) on sprocket guard to hole (b) of sprocket guard plate (B)

10-3 Replacing guide bar stud

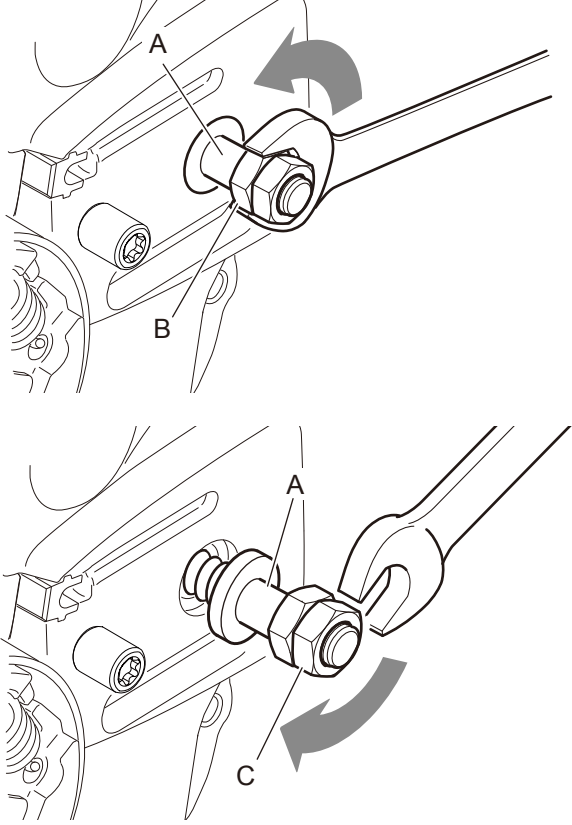

{Disassembling}

1. Remove chain catcher and sprocket guard plate from engine cover.
2. Install two nuts on defective stud (A) and tighten them against each other.
3. Turn nut (B) counterclockwise to remove stud.

NOTE: If it is hard to remove or broken stud is too short for tightening two nuts, hold defective stud by vise and turn the chain saw body counterclockwise, or use a suitable stud remover.

{Assembling}

4. Install two nuts on new stud and tighten them against each other.

NOTE: Apply a small amount of thread locking sealant in the thread hole (locktite #272 or equivalent).

5. Turn nut (C) clockwise to install stud.
6. Reassemble removed parts.

11 MAINTENANCE GUIDE

11-1 Troubleshooting guide

TROUBLE	
Engine does not crank.	01
Engine does not start.	02
Fuel leaks.	03
Idling is not stable.	04
Acceleration is poor.	05
Engine stalls at high speed.	06
Engine lacks power.	07
Engine seizure / overheat	08
Engine misfires.	09
Engine / others are extremely noisy.	10
Fuel consumption is excessive.	11
Vibration is excessive.	12
Engine does not stop.	13
Oiler does not function.	14
Saw chain does not cut well.	15

INSPECTING	REFERENCES	Inspecting <input checked="" type="radio"/> first.														
		15	14	13	12	11	10	09	08	07	06	05	04	03	02	01
Starter system		15	14	13	12	11	10	09	08	07	06	05	04	03	02	01
Starter pawl/spring	2-4															<input checked="" type="radio"/>
Starter drum/rope	2-2															<input type="radio"/>
Rewind spring	2-3															<input type="radio"/>
Ignition system		15	14	13	12	11	10	09	08	07	06	05	04	03	02	01
Sparks	3-2							<input checked="" type="radio"/>			<input type="radio"/>	<input type="radio"/>	<input type="radio"/>		<input checked="" type="radio"/>	
Spark plug	3-3							<input type="radio"/>	<input type="radio"/>		<input type="radio"/>	<input type="radio"/>	<input type="radio"/>		<input type="radio"/>	
Spark plug cap / coil	3-4							<input type="radio"/>							<input type="radio"/>	
Ignition switch	3-5			<input checked="" type="radio"/>				<input type="radio"/>							<input type="radio"/>	
Ignition coil	3-7							<input type="radio"/>			<input type="radio"/>	<input type="radio"/>	<input type="radio"/>		<input type="radio"/>	
Pole shoe air gaps	3-8							<input type="radio"/>	<input type="radio"/>				<input type="radio"/>		<input type="radio"/>	<input type="radio"/>
Flywheel	3-9				<input type="radio"/>			<input type="radio"/>					<input type="radio"/>		<input type="radio"/>	
Flywheel key	3-9							<input type="radio"/>	<input type="radio"/>	<input type="radio"/>		<input type="radio"/>	<input type="radio"/>		<input type="radio"/>	
Clutch system		15	14	13	12	11	10	09	08	07	06	05	04	03	02	01
Clutch shoes/spring/bearing	5-1 to 5-3	<input type="radio"/>			<input type="radio"/>		<input type="radio"/>									
Clutch drum	5-1, 5-3	<input type="radio"/>			<input type="radio"/>		<input type="radio"/>									
Sprocket	1-5, 5-1	<input type="radio"/>			<input type="radio"/>											

(Continued)

11-2 Disassembly chart

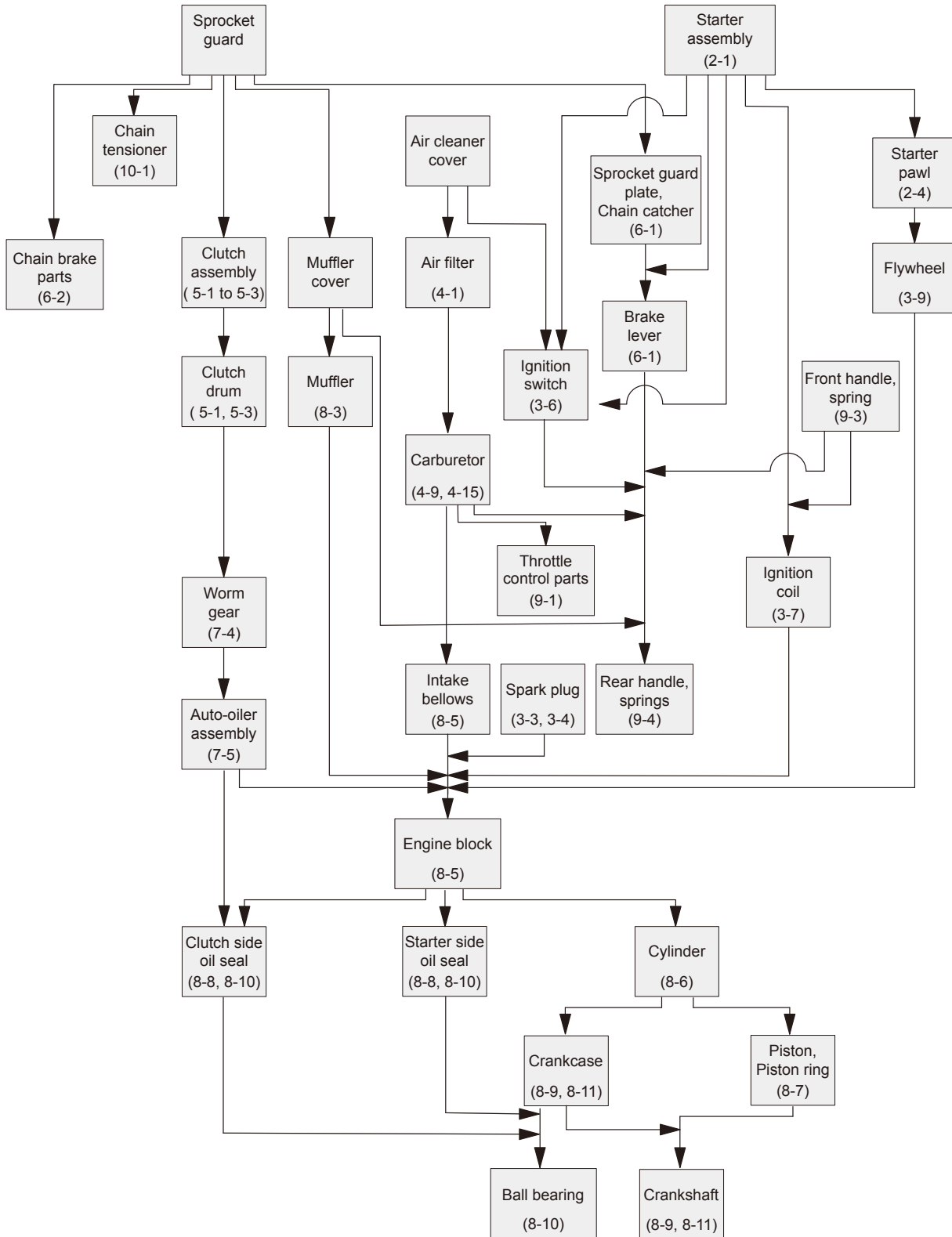

11-3 Service intervals

Inspecting point	Service	Reference	Intervals		
			Daily	3 months or 100 hours	6 months or 300 hours
Screws and bolts *	Retighten / Replace			○	
Air filter	Clean	4-1	○		
	Inspect / Replace	4-1		○	
Carburetor	Inspect / Repair	4-8 to 4-15			○
Fuel leaks	Inspect / Repair	4-4, 4-7	○ **		
Fuel line	Inspect / Repair	4-4, 4-7		○	
Cooling system	Inspect / Clean	8-2	○		
Spark plug	Clean / Regap	3-3		○	
	Inspect / Replace	3-2, 3-3			○
Fuel strainer	Clean / Replace	4-3		○	
Leads and connections	Inspect / Repair	3-5, 3-6		○	
Fuel tank	Clean inside.	4-4		○	
Muffler and exhaust port	Clean	8-3		○	
Starter system	Inspect / Repair	2-1 to 2-4		○	
Oil tank	Clean inside.			○	
Oil strainer	Clean / Replace	7-1		○	
Sprocket	Inspect / Replace	1-5, 5-1		○	
Guide bar	Inspect / Clean		○		
Chain brake	Inspect / Repair	6-1 to 6-3	○		

Daily: Inspecting in every services.

IMPORTANT: Service intervals shown above are maximum. Actual use and your experience will determine the frequency of required maintenance.

* Retighten the following screws and bolts after first 1 week use, and every 3 months.

- Starter assembly screws (3 pcs.)
- Counter-vibration spring screws (4 pcs.)
- Front handle screws (2 pcs.)
- Muffler bolts (3 pcs.)

** Inspect after every refuel.

ECHO®

shindaiwa®

YAMABIKO

Published by
YAMABIKO Corp.
Tokyo Japan

1910