



SERVICE DATA

CHAIN SAW

ECHO: CS-4510ES

shindaiwa: 451s

(Serial number : 37000001 and after)

(Serial number : 38000001 and after)

INTRODUCTION

We are constantly working on technical improvement of our products. For this reason, technical data, equipment and design are subject to change without notice. All specifications and directions in this SERVICE DATA are based on the latest product information available at the time of publication.

CONTENTS

1 SERVICE INFORMATION.....	2
1-1 Specifications.....	2
1-2 Technical data.....	4
1-3 Torque limits.....	5
1-4 Special maintenance materials.....	5
1-5 Service limits.....	6
1-6 Special tools.....	7

Caburetor Adjustment video

CLICK HERE



Reference No. **01-45E-04**

REVISED: 202104

ISSUED: 201801



1 SERVICE INFORMATION

1-1 Specifications

Dimensions	Length*	mm(in)	437 (17.2)
	Width	mm(in)	237 (9.3)
	Height	mm(in)	298 (11.7)
Dry weight*		kg(lb)	5.0 (11.0)
Engine	Type	YAMABIKO, stratified scavenging, air-cooled, two-stroke, single cylinder	
	Rotation	Clockwise as viewed from the output end	
	Displacement	cm ³ (in ³)	45.0 (2.746)
	Bore	mm(in)	43.0 (1.693)
	Stroke	mm(in)	31.0 (1.220)
	Compression ratio		7.3
	Carburetor	Type	Diaphragm, horizontal-draft
Model		ZAMA C1Q-110138C / C1Q-Z011/73B	
Venturi size-Throttle bore		mm(in)	16.0 - 17.5 (0.630 - 0.689)
Ignition	Type	CDI (Capacitor discharge ignition) system Digital Magneto	
	Spark plug	NGK BPMR8Y	
Exhaust	Muffler type	Spark arrester muffler	
Starter	Type	ES (Effortless-Start) / S (Soft-start)	
	Rope diameter x length	mm(in)	3.5 x 900 (0.13 x 35.4)
Fuel	Type**	Mixed two-stroke fuel	
	Mixture ratio	50 : 1 (2 %)	
	Gasoline	Minimum 89 octane	
	Two-stroke air cooled engine oil	ISO-L-EGD (ISO/CD13738), JASO FC/FD	
	Tank capacity	L (UK.fl.oz.)	0.48 (16.2)
Clutch	Type	Centrifugal, 3-shoe slide with 3-tension spring	
Guide bar / Saw chain lubrication type	Adjustable automatic oiler		
Oil	Tank capacity	L (UK.fl.oz.)	0.33 (11.2)
Auto oiler	Type	Clutch driven type	
Sprocket	Type	Spur	
	Number of teeth	7	
	Pitch	in	0.325

* Without guide bar and saw chain.

** Premixed alkylate fuel for 2-stroke can be used.

1-1 Specifications (continued)

Cutting devices					
Guide bar	Type	Y33S21-56ML	Y38R21-64AA Y38S21-64ML	Y45R21-72AA Y45S21-72ML	Y50R21-80AA Y50S21-80AL
	Called length	cm	33	38	45
	Gauge	in	0.058		
Saw chain	Type	OREGON 21BPX, Carlton K2L			
	Number of drive links	56	64	72	80
	Pitch	in	0.325		
	Gauge	in	0.058		

Cutting devices					
Guide bar	Type	Y33S20-56ML	Y38S20-64ML	Y45S20-72ML	Y50S20-80AL
	Called length	cm	33	38	45
	Gauge	in	0.050		
Saw chain	Type	OREGON 95TXL			
	Number of drive links	56	64	72	80
	Pitch	in	0.325		
	Gauge	in	0.050		

1-2 Technical data

Engine			
Compression pressure	MPa (kgf/cm ²) (psi)	1.06 (10.8) (154)	
Clutch engagement speed	r/min	4,150	
Ignition system			
Spark plug gap	mm(in)	0.6 - 0.7 (0.024 - 0.028)	
Spark test	Tester gap w/ spark plug	mm(in)	4.0 (0.16)
	Tester gap w/o spark plug	mm(in)	6.0 (0.24)
Secondary coil resistance	Ω	785 - 1185	
Pole shoe air gaps	mm(in)	0.3 - 0.4 (0.012 - 0.016)	
Ignition timing	at 3,000 r/min	°BTDC	13
	at 10,000 r/min	°BTDC	31
Carburetor			
Test Pressure, minimum	MPa (kgf/cm ²) (psi)	0.05 (0.5) (7.0)	
Metering lever height	mm(in)	0.1 - 0.25 (0.004 - 0.010) lower than diaphragm seat	
Tool to adjust mixture needles		D-shaped tool (L) P/N: X645-000031	
Carburetor adjustment			
1) Initial setting	H mixture needle	turn out	2 7/8
	L mixture needle	turn out	1 7/8
	Throttle adjust screw	turn out* ¹	8 1/8
Engine warm-up	Idle - WOT : Total	sec.	5 - 10 : 150
2) Verify engine speed and smooth acceleration		r/min	Idle: 2,700 - 3,500 WOT: 12,250 - 12,650 If it is not, proceed to the next step 3).
	3) Find idle maximum speed		Adjust L mixture needle to maximum idle speed.* ²
4) Set idle maximum speed w/ TAS		r/min	4,100
5) Set idle speed by turning L mixture needle CCW		r/min	3,100* ³
6) Confirm H mixture needle position before WOT setting			Turn H mixture needle CCW to confirm engine speed decreases less than or equal to 12,250 r/min.
7) WOT setting			Turn H mixture needle CW in 1/8 turn increment with the engine at idle, then accelerate to WOT and check engine speed.* ⁴ The final engine speed should fall within
		r/min	12,250 - 12,550
8) Verify final engine speed with standard equipment			Idle: 2,700 - 3,500 WOT: 12,250 - 12,650
		r/min	
9) Verify clutch engagement speed			Confirm clutch engagement speed. If it is less than 1.25 times the idle speed, adjust the idle speed by turning TAS CCW.
Chain oil discharge volume	mL/min(UK.fl.oz./min)		Adjustable: 1.5 - 13 (0.05 - 0.46) (Factory set: 7 mL/min)

BTDC: Before top dead center. **WOT:** Wide open throttle **CCW:** Counterclockwise **TAS:** Throttle adjust screw

*¹ Turn TAS clockwise until lightly seated. Then turn TAS counterclockwise.

*² If clutch engages during adjustment process 2), decrease engine speed by turning TAS CCW until clutch disengages and then redo 2).

*³ When using Premixed alkylate fuel, verify smooth acceleration. If it is not, turn TAS 1/4 turn CW.

*⁴ When using Premixed alkylate fuel, do not turn the needle more than 1/4 turn CW from standard state.

1-3 Torque limits

Descriptions		Size	kgf•cm	N•m	in•lbf	
Starter system	Starter pawl	M5	40 - 60	4 - 6	35 - 52	
	Starter case	M5 [†]	25 - 40	2.5 - 4	18 - 35	
Ignition system	Flywheel (Magneto rotor)	M8	250 - 290	25 - 29	220 - 255	
	Ignition coil	M5	40 - 60	4 - 6	35 - 52	
	Spark plug	M14	130 - 170	13 - 17	110 - 150	
Fuel system	Carburetor	M5 [†]	30 - 40	3 - 4	26 - 35	
	Intake bellows	M4*	30 - 45	3 - 4.5	26 - 40	
Clutch	Clutch shoe	LM8	300 - 400	30 - 40	262 - 350	
Engine	Crankcase	M5*	50 - 70	5 - 7	45 - 60	
	Engine mount	M5	70 - 110	7 - 11	60 - 95	
	Cylinder cover	M5 [†]	25 - 40	2.5 - 4	18 - 35	
	Cylinder plug	M4	30 - 45	3 - 4.5	26 - 40	
	Muffler	M5	90 - 110	9 - 11	80 - 95	
Others	Auto-oiler	M5	30 - 45	3 - 4.5	26 - 40	
	Front handle		M5 [†]	25 - 40	2.5 - 4	18 - 35
		Cylinder side	M5	50 - 70	5 - 7	45 - 60
	Rear handle assembly	M5 [†]	25 - 40	2.5 - 4	18 - 35	
	Spike	M5 [†]	50 - 70	5 - 7	45 - 60	
	Brake lever (Hand guard)		M4 [†]	25 - 35	2.5 - 3.5	18 - 30
			M5 [†]	25 - 40	2.5 - 4	18 - 35
	Stud bolt	M8 [†]	160 - 220	16 - 22	140 - 190	
	Guide bar	M8	200 - 230	20 - 23	175 - 200	
	Regular bolt, nut and screw		M3	6 - 10	0.6 - 1	5 - 9
		M4	15 - 25	1.5 - 2.5	13 - 22	
		M5	25 - 45	2.5 - 4.5	22 - 40	
		M6	45 - 75	4.5 - 7.5	40 - 65	

LM: Left-hand thread *Apply special repairing materials

† Tapping screw

1-4 Special maintenance materials



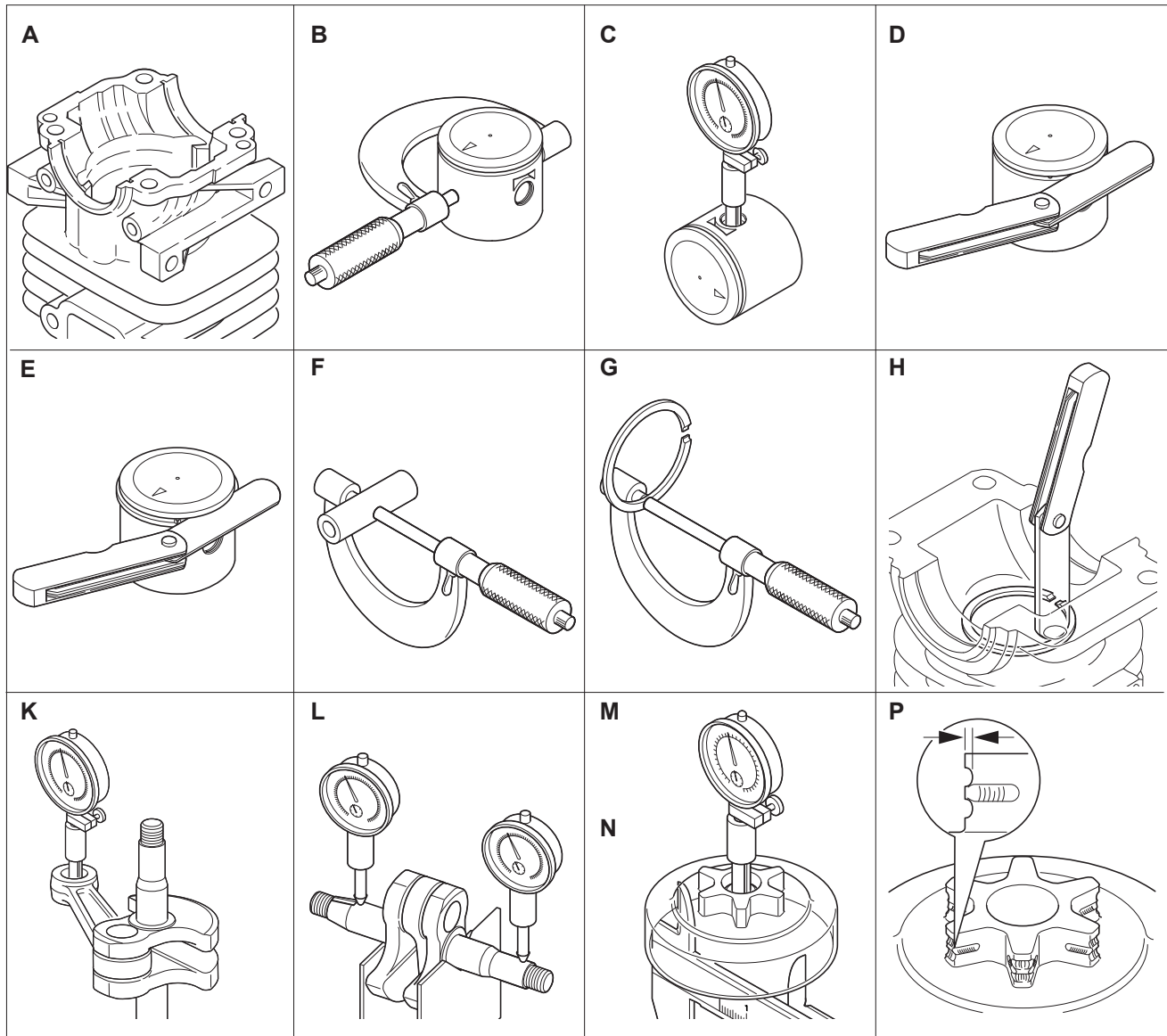

Material	Location	Remarks
Adhesive	Main bearing	Loctite #675 or equivalent
	Stud bolt	Loctite #272 or equivalent
Thread locking sealant	Intake bellows	Loctite #222, ThreeBond #1342 or equivalent
Grease	Clutch needle bearing	EPNOC AP2 (Lithium based grease) P/N X695-000060
	Starter center shaft	
	Engine cover	
	Cushion	
	Oil seal inner lips	
	Air cleaner cover	
	Chain brake (metal contact part)	Molybdenum grease (approx.1 gram)

1-5 Service limits

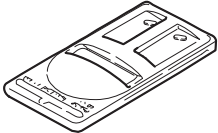
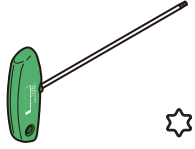
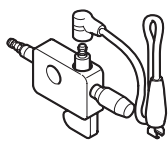
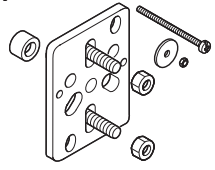

Description		mm (in)	
A	Cylinder bore	When plating is worn and aluminum can be seen	
B	Piston outer diameter	Min.	42.90 (1.689)
C	Piston pin bore	Max.	10.035 (0.3951)
D	Piston ring groove	Max.	1.6 (0.063)
E	Piston ring side clearance	Max.	0.1 (0.004)
F	Piston pin outer diameter	Min.	9.98 (0.3929)
G	Piston ring width	Min.	1.45 (0.057)
H	Piston ring end gap	Max.	0.5 (0.02)
K	Con-rod small end bore	Max.	14.025 (0.5522)
L	Crankshaft runout	Max.	0.01 (0.0004)
M	Sprocket bore	Max.	12.80 (0.5039)
N	Clutch drum bore	Max.	71.5 (2.81)
P	Sprocket wear limit	Max.	0.5 (0.02)

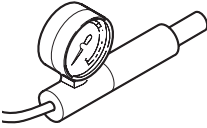
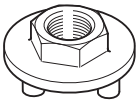
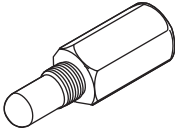
1-6 Special tools

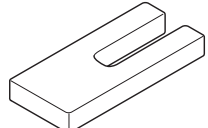
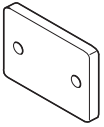
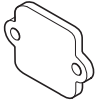
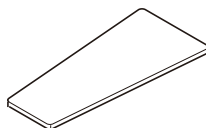
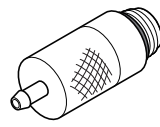
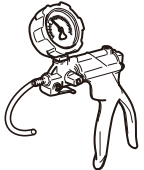
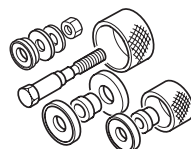
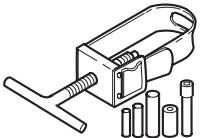
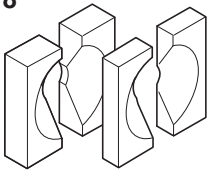
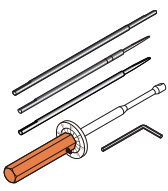
1		2		3		4		5	
6		7		8		9		10	
11		12		13		14		15	
16		17		18		19			

Key	Part Number	Description	Reference
1	897802-33330	Tachometer PET-1000R	Measuring engine speed to adjust carburetor
2	X602-000340	Torx wrench (T27)	Removing and installing Torx bolt
3	897800-79931	Spark tester	Checking ignition system
4	Y089-000111	Puller	Removing magneto rotor (flywheel)
5	91004	Module air gap gauge	Adjusting pole shoe air gaps
6	897803-30133	Pressure tester	Testing carburetor and crankcase leakage
7	897505-16133	Clutch tool	Removing and installing clutch assembly
8	X644-000020	Piston stopper	Locking crankshaft rotation
9	91037	Compression gauge	Measuring cylinder compression
10	897719-02830	Piston holder	Making piston steady to remove and install piston/ring
11	897826-16131	Pressure rubber plug	Plugging intake port to test crankcase / cylinder leakages
12	897827-16131	Pressure plate	Plugging intake port to test crankcase / cylinder leakages
13	91041	Pressure rubber plug	Plugging exhaust port to test crankcase / cylinder leakages
14	A131-000150	Pressure connector	Testing crankcase and cylinder leakage
15	91149	Pressure / vacuum tester	Testing tank vent and crankcase leakages
16	897701-14732	Bearing tool	Removing and installing ball bearings on crankcase
17	897702-30131	Piston pin tool	Removing and installing piston pin
18	897701-02830	Bearing wedge	Removing ball bearings on crankshaft
19	Y089-000094	Carburetor adjustment tool	Adjusting carburetor