

STIGA



WORKSHOP MANUAL

**PARK PRO 900
2022 - 2024**



TABLE OF CONTENTS

- 1 - General instructions**
- 2 - Chassis and body**
- 3 - Steering**
- 4 - Hydraulic system**
- 5 - Belts**
- 6 - Control Wires**
- 7 - Electrical system**

All brands, names, logos and trademarks mentioned belong to their respective owners.

© by STIGA - No use of the illustrations or duplication, reproduction or translation, even partial, of the texts in this document may be made without explicit authorisation.

1 - General instructions

Contents in this chapter

1.1 Introduction	2	1.3 Unpacking and assembly	4
1.1.1 Responsibility declaration	2	1.3.1 General.....	4
1.1.2 How this manual is used	2	1.3.2 Tyres.....	4
1.1.3 Abbreviations.....	2	1.3.3 Battery.....	5
1.2 Safety Precautions	2	1.3.4 Final checks.....	6
1.2.1 Symbols and general warnings.....	3	1.4 Service	7
1.2.2 Warm parts	3	1.4.1 Service times.....	7
1.2.3 Moving parts.....	3	1.4.2 First Service	8
1.2.4 Lifting and blocking up.....	3	1.4.3 Intermediate Service.....	8
1.2.5 Cleanliness.....	3	1.4.4 Basic control.....	9
1.2.6 Tightening torque.....	3	1.4.5 Description of service points.....	10
1.2.7 Sharp edges	3	1.5 Oil and filter	13
1.2.8 Replacement parts	3	1.6 Technical specifications	13
1.2.9 Inspection.....	3	1.7 General tightening torque	13

General

This Workshop Manual is intended for STIGA PARK PRO 900.

This Manual do not cover repair instructions for the engines. Regarding engines, contact the respective representative in the actual country.

This Manual and its specifications are valid for machines in their original design. In case of modified or changed machine, i.e. the engine is replaced, the manual accordance is limited.

The manual is divided in the following chapters:

Chapter 1 - is this chapter

Chapter 2 - Chassis

Chapter 3 - Steering

Chapter 4 - Hydraulic system

Chapter 5 - Belts

Chapter 6 - Control Wires

Chapter 7 - Electrical system

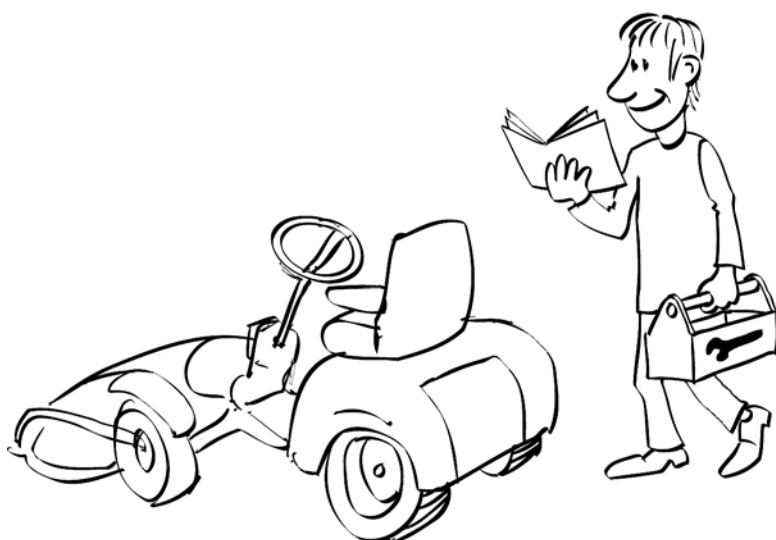

1.1 Introduction

1.1.1 Responsibility declaration

In spite of the great care we have taken there may be errors in this publication.

The author cannot be made liable for incorrect or missing information.

STIGA reserves the right to regularly change product specifications without prior notice. All the information in this book is based on the information available at the time of production.

Illustrations and photographs may be arranged schematically, which implies that one picture may cover several models and therefore not correspond exactly with all models.

1.1.2 How this manual is used

To make this manual easy to understand we have divided the machine into its main systems and components. These parts are now the different chapters in the book.

Each chapter is divided up into sections.

In each chapter there is a detailed table of contents so that you can easily and quickly find what you are looking for.

Always check that you are reading the right chapter for your particular machine before starting the repair work.

1.1.3 Abbreviations

The following abbreviations are used in this manual:

HST Hydrostatic Transmission PTO Power Take Off

1.2 Safety Precautions

This manual has been written primarily for trained mechanics working in a well-equipped workshop.

A basic knowledge of repairs, tools and repair instructions is, however, always a prerequisite for first-rate results.

A qualified mechanic should always be consulted if the owner does not have sufficient knowledge to carry out repairs.

During the warranty period all service must be carried out by an Authorised Workshop for the warranty to be valid.

The following basic points should be observed if the machine is to function perfectly:

- Follow the service schedule.
- Be on the alert for sudden vibrations or abnormal noise to avoid major breakdowns.
- Always use Genuine Spare Parts
- Follow the descriptions in this manual carefully. Do not take any short cuts.

1.2.1 Symbols and general warnings



Warning! This symbol indicates a risk of personal injury or damage if the instructions are not followed.



Note! This text indicates a risk of damage to the material or risk of unnecessarily complicated work if the instructions are not followed.

1.2.2 Warm parts

Please observe that engine and exhaust system picks up a lot of heat during use. To avoid injuries, allow the machine to cool before any kind of repairs are made to or near parts of the engine or exhaust system.

1.2.3 Moving parts

The machines are all equipped with v-belt transmissions. Always stop the engine and remove the starter key before inspections or repairs are carried out.

Always use extreme caution when testing systems with moving parts to avoid injuries.

Always use Genuine Spare Parts during service work.

1.2.4 Lifting and blocking up

Before work under the machine, always make sure that lifting devices and jack-stands are approved for the weight. Work safe!

1.2.5 Cleanliness

Clean the machine before starting repairs. Dirt that penetrates into sensitive components can seriously influence the service life of the machine.

1.2.6 Tightening torque

Unless otherwise stated the tightening torque in the tables in the section Technical specifications must be used for the different sizes of screws.

This does not refer to self-tapping screws, which are mainly used for the assembly of body parts.

1.2.7 Sharp edges

Watch out for sharp edges, especially when working with the mower deck. The blades can be very sharp. Always wear gloves when working with the blades.

1.2.8 Replacement parts

Always use Genuine Spare Parts during service work.

1.2.9 Inspection

Each part dismantled in conjunction with service work must be inspected.

Examine for: wear, cracks, out of roundness, straightness, dents, discolouring, abnormal noise and jamming.

1.3 Unpacking and assembly

1.3.1 General

Every machine has undergone an extensive control programme before delivery. The machines are delivered as completely assembled as possible.

Thanks to this the assembly on delivery is rapid and easy.

The correct and careful assembly of the machine on delivery is a simple way of ensuring satisfied customers!

A complete assembly instruction is given in the owners manual delivered with the machine. This section will give complement information and explanations for the assembly.

! **Note!** The machine shall remain placed on the pallet during the unpacking and assembly.

1.3.2 Tyres

Check the air pressure in the tyres. The pressure is designated on the floor mat. The air pressure in the tyres is of critical importance for the performance and handling of the machine. The correct air pressure for mowing is 0.6 bar (9 psi) in the front tyres, and 0.4 bar (6 psi) in the rear tyres.

When using heavy accessories, e.g. snow thrower, it may be necessary to increase the pressure somewhat. However, the maximum permitted pressure is always 0.8 bar (12 psi).

Too high pressure in the tyres leads to that the machine drives poor due to:

- A small surface in contact to the ground.
- Hard tyre = less flexibility = self cleaning characteristic deteriorate.

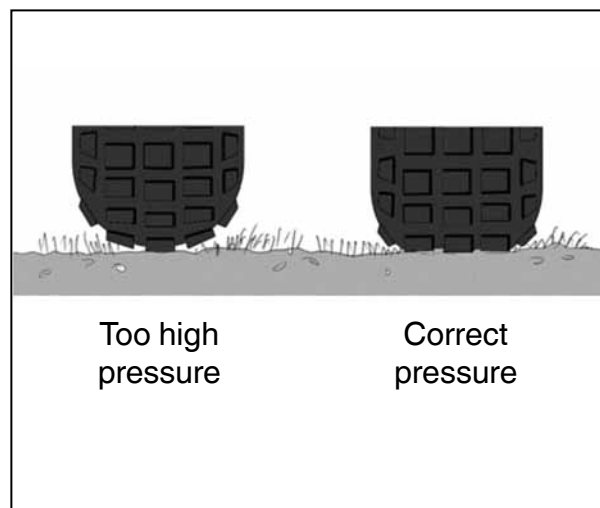

1.3.3 Battery

The battery is a valve regulated battery. Load and assemble the battery, following the instructions below.

The battery needs limited maintenance. It has no electrolyte levels or plugs.

 **Warning! Do not wear rings, metallic bracelet, chain round the neck or similar metal objects when working with the battery. It can cause short-circuit, burns and fire.**

 **Warning! The battery must be fully charged before being used for the first time. The battery must always be stored fully charged. If the battery is stored while discharged, serious damage will occur.**

Charging with the engine

The battery can be charged using the engine's generator as follows:

1. Install the battery in the machine as shown below.
2. Place the machine outdoors or install an extraction device for the exhaust fumes.
3. Start the engine according to the instructions in the user guide.
4. Allow the engine to run continuously for 45 minutes.
5. Stop the engine. The battery will now be fully charged.

Storage

The battery voltage is not allowed to drop under 12,5 V during storage.

Make sure that the battery voltage always is more than 12,5 during storage. If not, the battery will be destroyed.



 **If the cables are disconnected/connected in the wrong order, there is a risk of a short-circuit and damage to the battery.**

 **If the cables are interchanged, the generator and the battery will be damaged.**

 **The engine must never be driven with the battery disconnected. There is a risk of serious damage to the generator and the electrical system.**

Charging using battery charger

To access the battery, see "Battery replacement" on page 15 in section "7 – Electrical system".

When charging using a battery charger, a battery charger with constant voltage must be used. Ordering number: 1136-0602-01.

The battery can be damaged if a standard type battery charger is used

1.3.4 Final checks

Removing from pallet

All the above measures shall have been done with the machine standing on the pallet. Now, loosen the remaining straps and roll off the machine from the pallet.
Fit and adjust accessories.

Test driving



Warning! Do not drive without a work equipment (mower deck) attached. Risk for turning over.

Drive the machine for a few minutes. Test all the functions. Pay special attention to the safety functions. If the machine is to be delivered with mower deck or other accessories, fit these before test driving the machine.

HST oil

Check the oil level in the HST's expansion tank after test driving, and top up if necessary.

Engine oil

Check the oil level in the engine and top up if necessary.

Miscellaneous

Give the machine a general inspection

- Is the machine clean?
- Is there any oil leakage?
- Abnormal noise or rattle?

Receipt

By filling in the guarantee certificate you guarantee that the delivery service has been correctly conducted.

Remember to make sure that the customer receives all the documentation when the machine is collected / delivered.

1.4 Service

Every new machine is delivered with a service book. This service book is part of the active post-market programme and shall be kept in a safe place during the entire lifetime of the machine. Hand over the service book if the machine is sold in 2:nd hand.

Service should generally be carried out at least every 50 operating hours (exception of the first service), although in accordance with the conditions below.

There are three different grades of service events. Every service event consists of a number of service points as described in the following paragraphs. Every service point has a number which refer to a describing text after the schedules.

The grades of service events are:

- First service
- Intermediate service
- Basic service

Some service points do not coincide with the scheduled service intervals, but shall be performed in connection with a scheduled service when possible. E.g. some items shall be performed at every second service and some also between two services.

These service points are described with procedure and interval in the respective "Instruction for use".

Typical service points wich not coincide with scheduled service intervals are:

- Cleaning/changing air filter in some engines.
- Change of oil in some engines.
- Valve adjustments for some engines.
- Change of transmission oil.
- Change of spark plug in some engines.

1.4.1 Service times

The electronic equipment of the machine monitors the count-down and displays motor maintenance deadlines. The digits on the display begin to flash when the machine reaches the hourly threshold of intervention shown below:

Park PRO 900 AWX:	5 h	25 h (and all multiples of 25)
Park PRO 900 WX:	5 h	20 h 50 h (and all multiples of di 50)

This hour count is linked to the operating hours of the motor.

The flashing will continue for two minutes of motor operation and has priority over all other display functions. The MODE button remains inhibited during this phase. Once 99999 hours have been reached, the counter restarts from zero. Over 999 hours, minutes are not counted.

Service	Shall be performed
First service	Within 5 hours of running
Intermediate service	After the first 50 hours of running and then 50 hours after/before every basic service.
Basic service	Every 100 hours or every year, which first occur.

1.4.2 First Service

This service is very important to safeguard the continuing function of the machine. The first service includes the service points as per the table below.

Number	Service point
1	Safety check.
2	Tyres, air pressure.
3	Engine oil and filter, see "Oil and filter" at page 13.
4	Oil level in HST, see "Oil and filter" at page 13.
5	Belt transmissions, check.
6	Battery check.
19	Test driving.

1.4.3 Intermediate Service

The intermediate service is not as extensive as the Basic Service and can therefore be conducted by the customer, or by an authorised Service Workshop. Regardless of who conducts the service, it must be documented in the service book.

Number	Service point
1	Safety check.
2	Tyres, air pressure.
3	Engine oil and filter, see "Oil and filter" at page 13.
4	Oil level in HST, see "Oil and filter" at page 13.
7	Air filter, cleaning.
8	Cooling fins, clean.
9	Lubrication.

1.4.4 Basic control

This control must always be conducted by an authorized Service Workshop, and documented with a stamp in the service book.

Number	Service point
1	Safety check
2	Tyres, air pressure
3	Engine oil and filter, see "Oil and filter" at page 13.
4	Oil level in HST, see "Oil and filter" at page 13.
5	Belt transmissions, check
6	Battery check
7	Air filter for engine, see "Oil and filter" at page 13.
8	Cooling fins, clean
10	Transmission, check
11	Bearing boxes, check**
12	Exhaust system, check*
13	Electrical system, check*
14	Mower deck, check**
15	Blades, check**
16	Power take-off, check
17	Control check
18	Valve play***
19	Test driving

*) See also "Safety check".

***) See also the mower deck manual.

***) See the engine manual.

1.4.5 Description of service points

1. Safety check.

The machine is provided with safety devices/functions, related to the mechanical system and to the electrical system.

Test of the electrical system.

Test	Status	Action	Result
1	Operator not sitting in seat. Brake pedal pressed.	Turn the key and make a start attempt.	Engine shall not start and "SIT DOWN" shall be displayed.
2	Operator sitting in seat. Brake pedal not pressed.	Turn the key and make a start attempt.	Engine shall not start and "PRESS BRAKE" shall be displayed.
3	Engine running. PTO magnetic clutch activated.	Operator rises from the seat.	The engine shall stop.

Prova dei componenti meccanici

Test	Status	Action	Result
4	Fuel system and connections	Visual check	No leakage shall be observed.
5	Electrical cables	Visual check	All insulation OK and no mechanical damage.
6	Hydraulic system	Visual check	No leakage in hoses, connections or devices.
7	Drive the machine forwards and backwards.	Release the drive pedal.	The machine shall brake and stop
8	Driving test	Listen for abnormal noise and vibrations.	No abnormal noise or vibrations shall be observed.

2 Tyres, air pressure

Check the air pressure.

Adjust if necessary. The recommended air pressure is designated at the floor mat.

3 Engine oil and oil filter

See the "Instructions for use", delivered with the machine or "Instructions for use" at page 13. See also the engine manufacturer manual.

4 Oil, HST

See the owners manual, delivered with the machine.

5 Belt transmissions, check

Check the condition of all the belts and belt tensioners.

6 Battery check

Check the battery. Charge if necessary. See "Battery" at page 5.

7 Engine air filter

See the owners manual, delivered with the machine. See also the engine manufacturer manual.

8 Cooling fins

Remove protective covers from the engine and clean between cooling fins. Use a brush and compressed air. See also the engine manufacturer manual.

9 Lubrication

Lubricate the articulation point (4 nipples) and all moving parts such as wires and levers. See also the instruction manual, delivered with the machine.

10 Transmission

Listen for abnormal noise. Check that there is no oil leakage.

11 Bearing boxes

Listen for abnormal noise from the bearings. Check that there are no wear, play or seizure.

- Lubricate the axle shafts every 25 hours of operation.
- Emphasise to the user the importance of keeping the wheel hubs controlled and well lubricated, to avoid premature wear of the axle shafts and hubs.

12 Exhaust system

Check that there are no cracks, leakage or other damages. Check the attachment devices. See also the engine manufacturer manual.

13 Electrical system

Check that there are no damaged cables, contacts or other devices. Check that all cables are properly secured to the chassis and with cable holders. Check that there is no friction between cables and chassis, which can result in cable damage and short circuit.

14 Mower deck



Warning! The blades are sharp. Always wear gloves when working with the blades to avoid injury.

Check if there are collision damages or wear at the deck body and painting. Align, repair and touch up the painting as required.

Check the tightening of the bearing boxes screws and tighten.

Rotate the blades and check the the shafts are correct, not bent, no abnormal bearing noise and no plays.

Check the belts and their tensions, see section 4.

Check that the lifting mechanism moves evenly, not jammed and no play and that it locks in desired position.

15 Blades



Warning! The blades are sharp. Always wear gloves when working with the blades to avoid injury.

Check that the blades are sharp. Sharpen as required.

16 Power take-off (PTO)

Check that the magnetic clutch engage the work equipment rotation in the desired time and that it not slips during normal load. Replace the clutch if necessary.

Check that the power take-off brake (if applicable) brakes the rotation movement in the desired time. Adjust if necessary.

17 Control check

Check that all controls function properly, that there are no jammings or excessive plays.

18 Valve play

See the engine manual regarding procedure and interval.

19 Test driving

Drive the machine during a few minutes and make the following attentions in different speeds and turnings in right and left.

Check that all functions work evenly and proper and without any abnormal noise.

- Brake function
- Clutch function
- Power take-off
- Steering

Check that there are no abnormal vibrations.

1.5 Oil and filter

For information about oil- and filterdata for the engine and for the transmission, see the owners manual delivered with the machine. See also section 4 in this manual.

1.6 Technical specifications

For information about the technical specifications, see the owners manual delivered with the machine.

1.7 General tightening torque

Unless otherwise stated, the following tightening torque are applicable for screws and nuts on the machine:

Tightening torques :

Thread	Torque
M5	5,7 Nm
M6	9,8 Nm
M8	24 Nm
M10	47 Nm

2 - Chassis and body

Contents in this chapter

2.1 Rear wheel	2	2.5 Steering cylinder	14
2.1.1 Assembly.....	2	2.5.1 Dismantling.....	14
2.2 Lubrication	3	2.5.2 Assembly.....	14
2.3 Covers	5	2.6 Articulating point	15
2.3.1 Front engine covers	5	2.6.1 Dismantling.....	15
2.3.2 Covers around the articulating point.....	6	2.6.2 Assembly.....	16
2.3.3 Instrument covers	10	2.6.3 Replacing the yoke shaft.....	16
2.4 Hydraulic pump	11	2.7 Front transmission shafts repair method	17
2.4.1 Dismantling.....	11		
2.4.2 Assembly.....	13		

General

To facilitate the driving, handling of work equipment and to make it comfortable for the driver, the machines are equipped with a various number of aid equipments. These equipments are mainly the same for all the machines covered by this manual, but in some cases configured in different ways. Where divergences occur between the machines, particular instructions are given for each particular equipment.

This chapter gives a brief description of the equipments and describes their repair and re-placements.

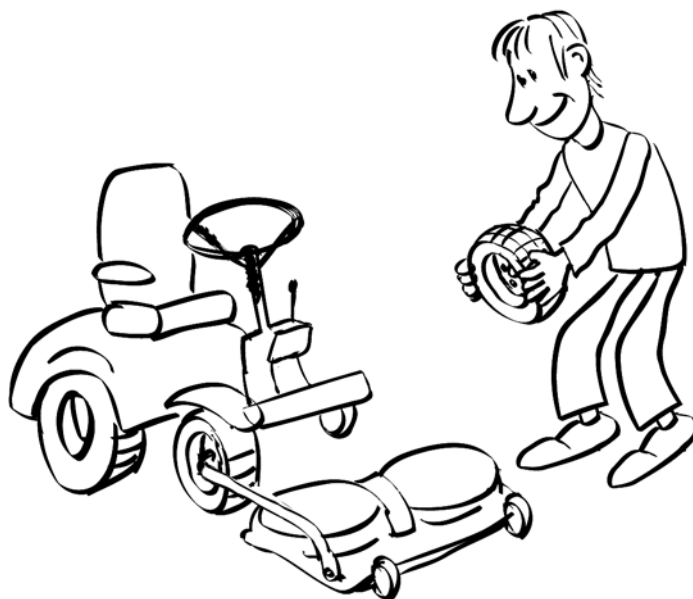

2.1 Rear wheel

2.1.1 Assembly

1. Push the hub on the shaft until it rests against the transmission body.
2. Assemble the washer and the circlip onto the shaft. The washer shall rest against the circlip.
3. Check the key and assemble it in the groove, against the washer.
4. Assemble the rear wheel without tightening the nuts.
5. Measure the distance (X) between the front wheels and adjust the rear hubs until the distance between the rear wheels is the same (X).

Pull out the hubs until the measure (Y) is the same at the both sides.

! **Note!** If the measures between the wheels front and rear not is the same, the machine will be hard to steer.

6. Tighten the two allen screws, using a 8 mm allen key.

The tightening shall be performed in two steps. Tighten first to 18 Nm and then, finally to a torque of 24 Nm.

7. Assemble the rear wheel and the protecting cover.

Assembly when tyre chains are used.

To give place for the tyre chains, the distance X can be increased. If necessary until the hub rests against the washer.

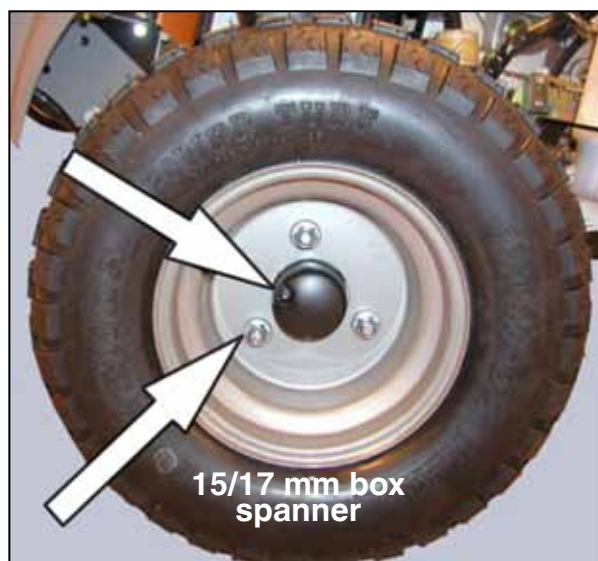
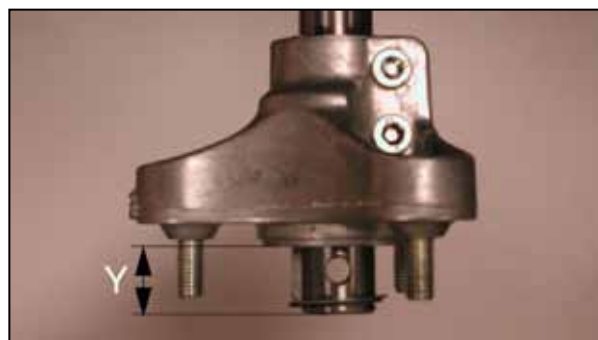
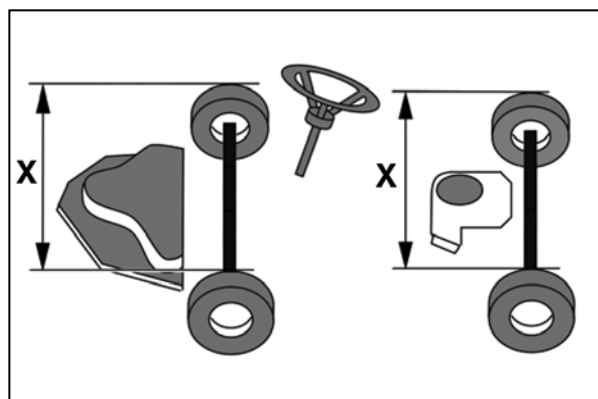

2.2 Lubrication

The lubrication must be performed in accordance with the service schedule. See the maintenance manual delivered with the machine.

- ! **Note!** Lubrication is equally important for a machine that is only used for a few hours per year.
- ! **Note!** The lubricant provides not only protection from wear but also from rust.
- ! **Note!** The machine should always be lubricated before prolonged storage.

The lubrication is described in the table below and in the figure at the next page.

Object	Action	Pos.
Centre point	3 grease nipples located on the central articulation on the left-hand side of the machine. Use a grease gun filled with universal grease. Pump until the grease seeps out.	A
Steering wheel (740 IOX, 540 IX)	2 grease nipples located on the central articulation on the left-hand side of the machine. Use a grease gun filled with universal grease. Pump until the grease seeps out.	B
Tensioning arms	Lubricate the support points of the tensioning arms with oil.	C
Wheel bearings	2 grease nipples. Use a grease gun filled with universal grease. Pump until the grease seeps out.	D
Quick-release supports	1 grease nipple for each front wheel. Use a grease gun filled with universal grease. Pump until the grease seeps out.	E
Control cables	Lubricate the control cable ends with oil.	F

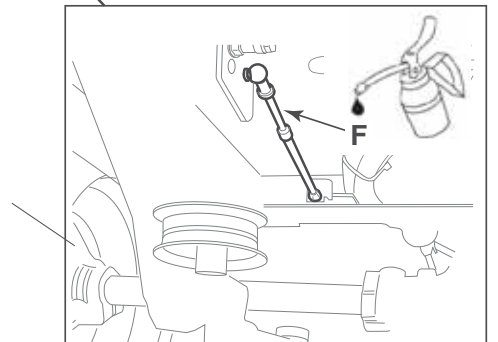
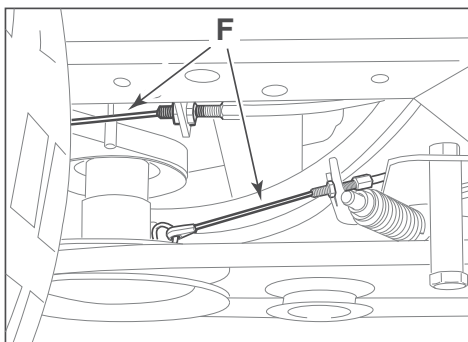
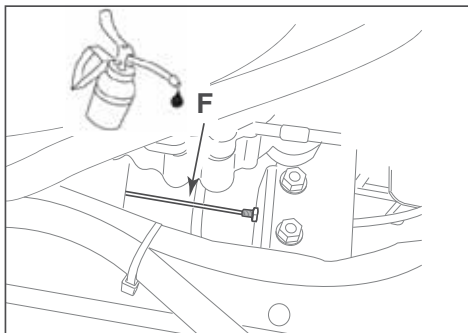
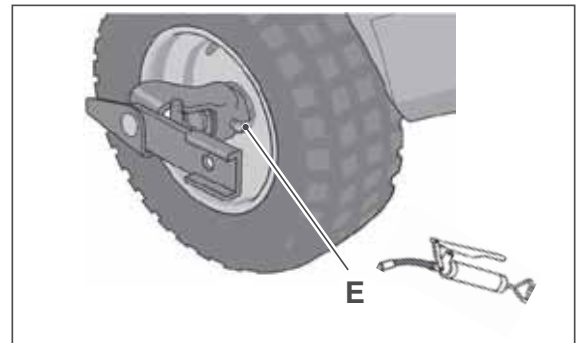
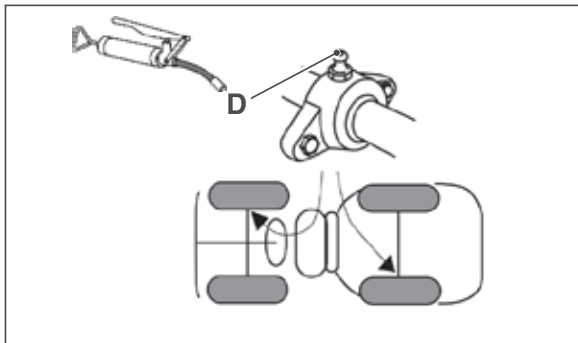
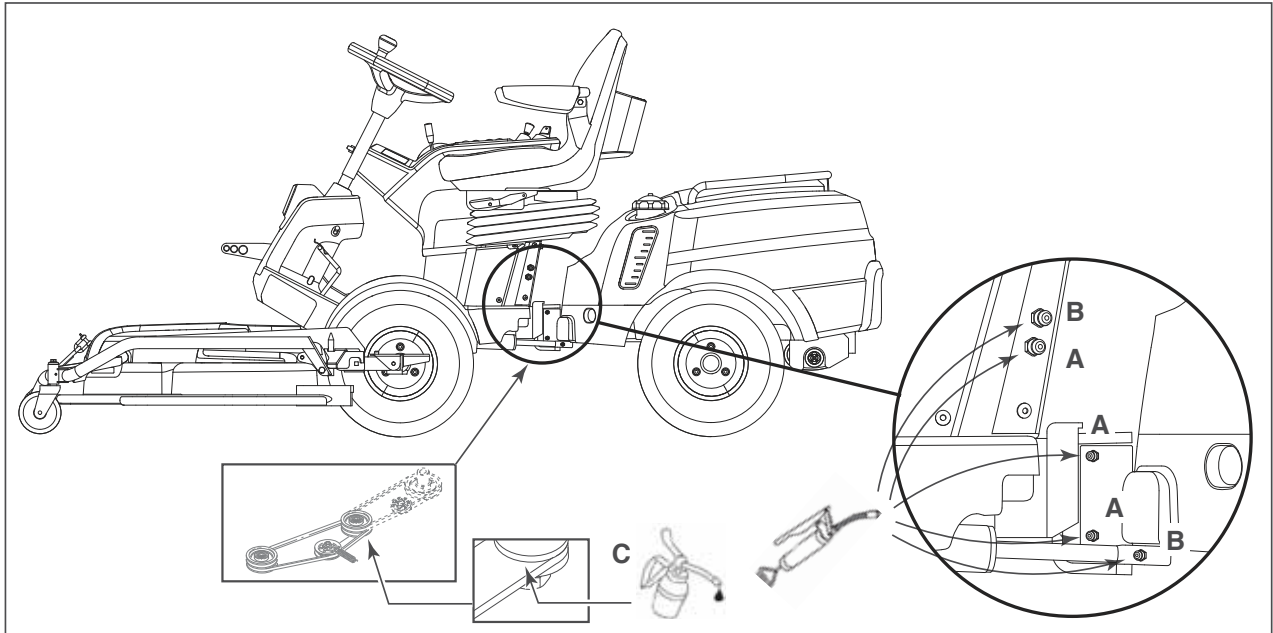

2.3 Covers

2.3.1 Front engine covers

Upper front cover

The upper front engine cover has to be removed in the following cases:

- Access to the battery.
- Access to the fuses.
- Removing of the lower case.

Dismantle the front upper cover as follows:

1. Loosen the two bayonet sockets, release the handle and fold back the upper cover. See the owners manual.
2. Unscrew 4 screws at each side. See the fig. Use a 4 mm allen key.



Warning! Petrol is highly inflammable. Never smoke when handling petrol. Never remove the filler cap while the engine is running or still warm or when hot objects are present.

3. Remove the fuel cap.
4. Lift up and remove the cover.
5. Assemble the fuel cap.
6. Assemble the cover in the reverse order.

Lower front cover

The lower front engine cover has to be removed among others in the following cases:

- Access to the steering cylinder.
- Access to wires and hoses.
- Access to the tank attachments.

Dismantle the front lower cover as follows:

1. Remove the upper front cover. See above.
2. Unscrew 1 screw at each side. Use a 4 mm allen key and preferably a mirror to locate the screws. See the fig.



 **Warning! Don't try to remove the cover without dismantle the tank. This will destroy both the cover and the seat bellow.**

 **Warning! Petrol is highly inflammable. The fuel cap must be on and tight when moving the tank..**

3. Move the cover forwards until the tank attachment wing nuts are free and remove the nuts.
4. Place the tank upon the engine and remove the cover.



IMPORTANT - Carefully check that the positive wires (red) are integral, that the insulation is not cracked or worn and that the corrugated protection sheath is installed and correctly mounted to prevent cables from being crushed by the battery housing after installation.

For machines without corrugated protection sheath, this must be installed following the instructions provided (see 7.9).

5. Assemble the cover in the reverse order.
6. **Important steps during the assembly of the lower cover and the tank:**
First set the cover in place without fasten it **with** its screws.
Then set the tank in place and fasten it with **its** attachments.
Finally fasten the lower cover with its two **screws**.

2.3.2 Covers around the articulating point

Dismantling

Dismantle the covers around the articulating point as follows:

1. Unscrew the two M6 nuts, one at each side and remove the protecting bar. Use a mirror to locate the nuts.

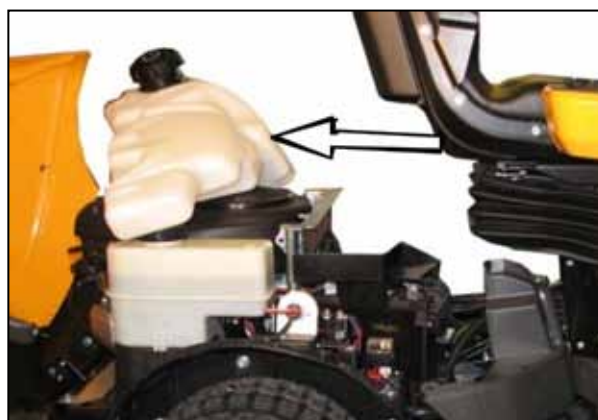

2. Unscrew one M6 nut from the under side and one screw and remove the left floor cover.



3. Unscrew one M6 nut from the under side and one screw and remove the left front art. cover.



4. Unscrew the screw under the right floor cover. See the figure. Remove the cover. Use a mirror to locate the screw. under the floor.



5. Unscrew the nut and unhook the spring. See the fig.

Unscrew also the nut from the underside behind the pulley.

Remove the cover and the pulley with parts.

6. Unscrew the remaining screws and nuts and remove the rest of the cover parts. Use a mirror to find the screws and nuts.

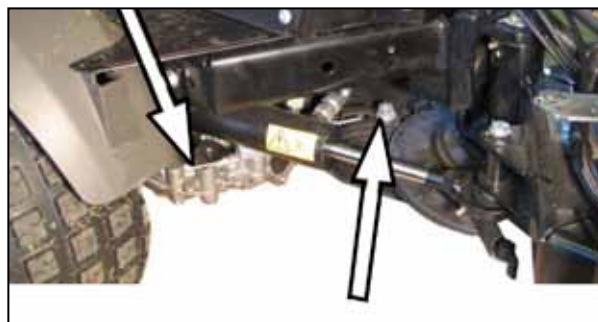

7. If necessary, dismantle the right cover according to the figure.

The following cover screws are shown in the figure:

- Visible to the right, close to the art. point.
- From the underside. See in the mirror
- One M6 nut with washer accessible from the wheel department.

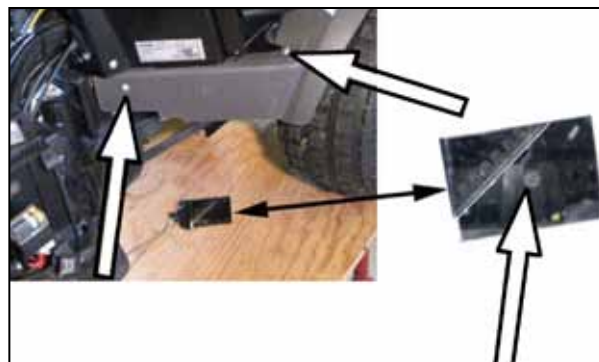

8. Check that the fuel cock is correct placed in the opening of the cover. See the figure.

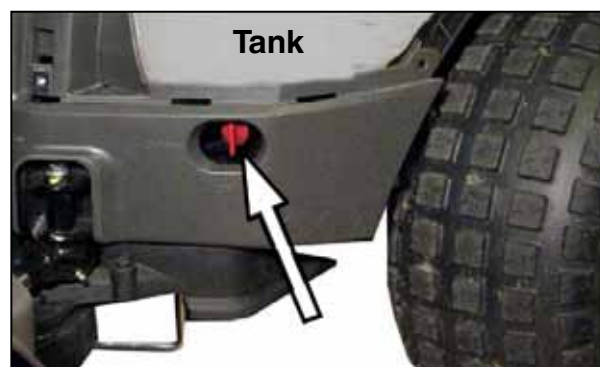

Assembly

The assembly of the covers are performed in the reverse order as follows:

1. Start with the rear parts and the parts around the art. point. See the fig.

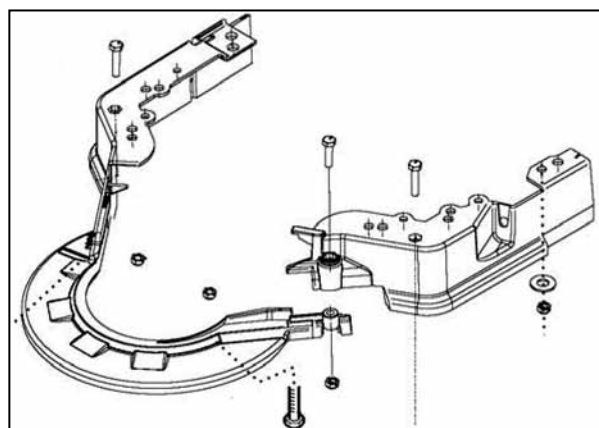

2. Then assemble the pulley with covers. Note the fitting of the pulley and its sleeves.

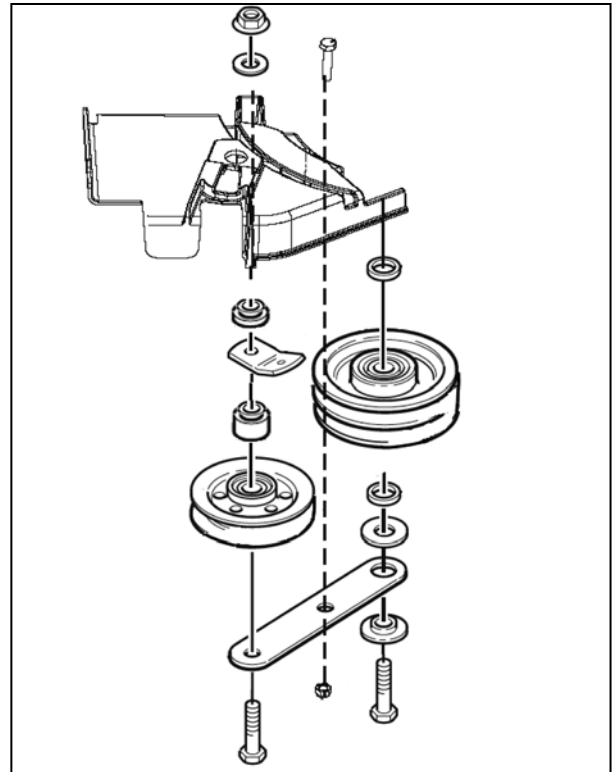

3. Fit the front protecting bar.

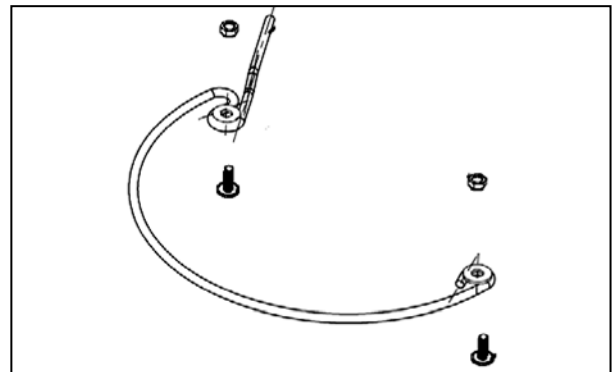

4. Assemble the remaining covers and the rear protecting bar.

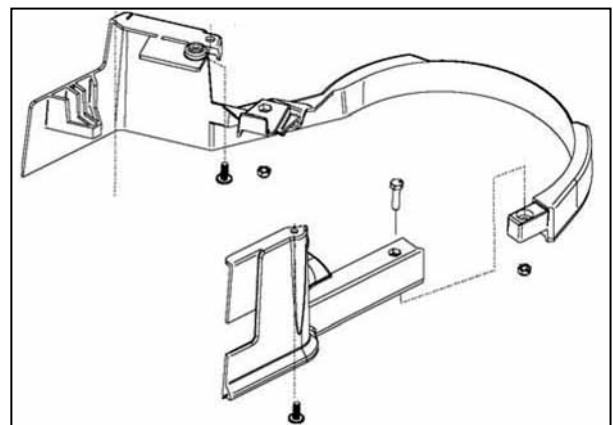

5. Locating of washers at the rear protecting bar.

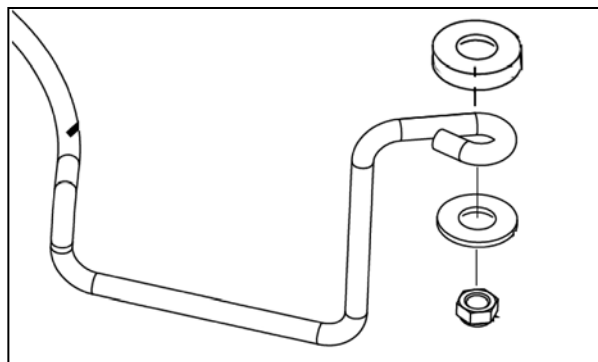

2.3.3 Instrument covers

To get access to instrument levers, electronics and wires, etc, the instrument covers have to be dismantled

Warning! If the seat is folded without the rivets removed, the bellow will be destroyed.

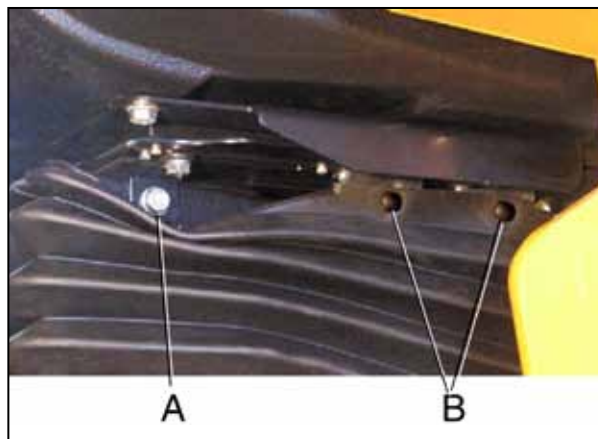

Dismantle the covers as follows:

1. Unscrew two M8 screws (A), one at each side and pull out four bellow rivets (B), two at each side.
2. Fold the seat forwards, unscrew 6 screws and remove the outside cover.

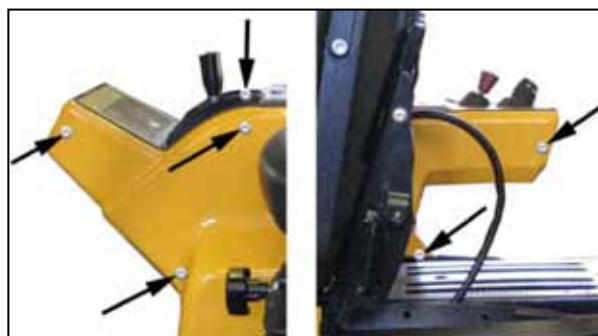

3. Unscrew the four inside screws with an 8 mm spanner and remove the inside cover.
4. The assembly is performed in the reverse order.



2.4 Hydraulic pump

This section will describe the replacement procedure for the external hydraulic pump in 4WD Park machines.

2.4.1 Dismantling

1. Block up the machine. Use a lifting table or highjack and yokes.
2. Activate the parking brake.
3. Discharge the oil in the hydraulic system. See the owners manual.
4. Remove the following parts:
 - Front engine covers with fuel tank. See "Front engine covers" page 5.
 - Plastic cover behind the art. point at the right side. See "Covers around the articulating point" page 6.
5. Turn the steering wheel fully at left and remove the speed control cable from the hydraulic pump by backing off the nut. Use a 8 mm spanner.
6. Back off the circlip from the release lever rod and disconnect the rod from the lever.

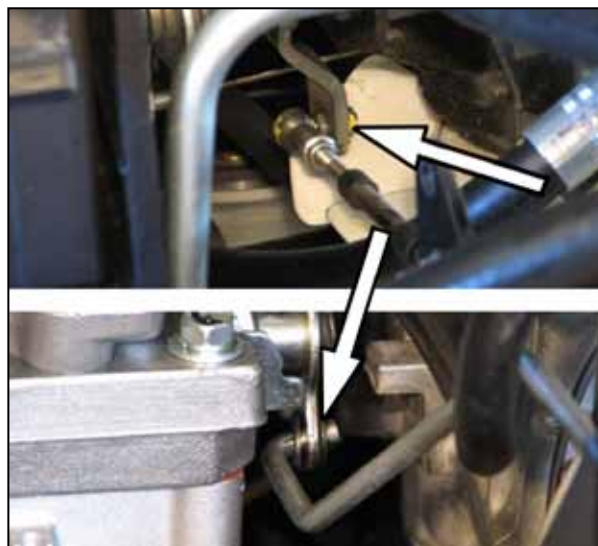

7. Use a large polygrip (A) and hold the pump pulley in a secu rely grip. Fit the polygrip around the belt, not direct to the pylley. Back off the pulley nut with a 17 mm sleeve. See the figure.





Be carefully not to damage the plastic fan during the removal.

8. Remove the following parts from the pump shaft:

- Nut
- Washer
- Pulley
- Distance sleeve
- Fan
- Distance sleeve

9. Place a collecting tray under the pump for collecting residual oil from the pump and hoses.



Warning! Do not spill any oil on the drive belts during the disconnection of hoses and tubes.



Warning! Keep clean when handling hydraulic parts. Dirt in the oil will cause malfunctions and breakdowns.

10. Disconnect all hoses and tubes from the hydraulic pump. Always use two spanners, one to hold the respective connection in the pump and one to loosen the nut. See the figure.



11. Remove the pump from the chassis by unscrewing the two M10 mounting nuts and screws. Use two 17 mm spanners. See the figure.

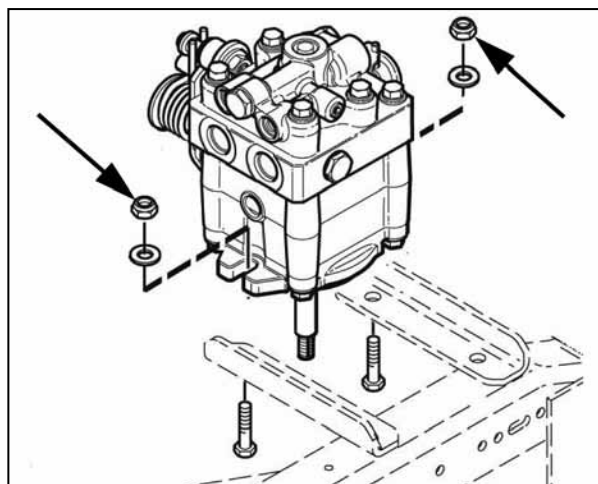

12. Place and fasten the pump in a table vice. Loosen the adapters from the pump.
13. Screw out the adapters and insert them in the corresponding places in the new pump one at a time. Check or replace the O-rings.
14. Place and fasten the new pump in a table vice. Tighten the adapters to torques according to the figures.
 When tightening the angle adapter (A), adjust it to 45° according to the horizontal line. Use one 14 mm and one 19 mm spanner.

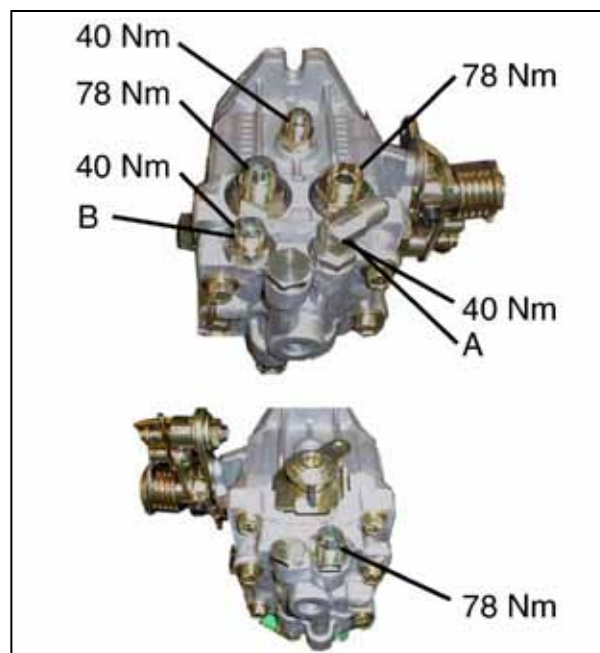

2.4.2 Assembly



Warning! Keep clean when handling hydraulic parts. Dirt in the oil will cause malfunctions and breakdowns.



Warning! Be carefully not to damage the plastic fan during the assembly.

Assemble all parts in the reverse order.



Note! One distance sleeve (C) at each side of the fan.

Adjust the speed cable. See section 6.

When all parts are fitted and all actual tightening torques are applied, fill new oil and bleed the hydraulic system. See the owners manual.

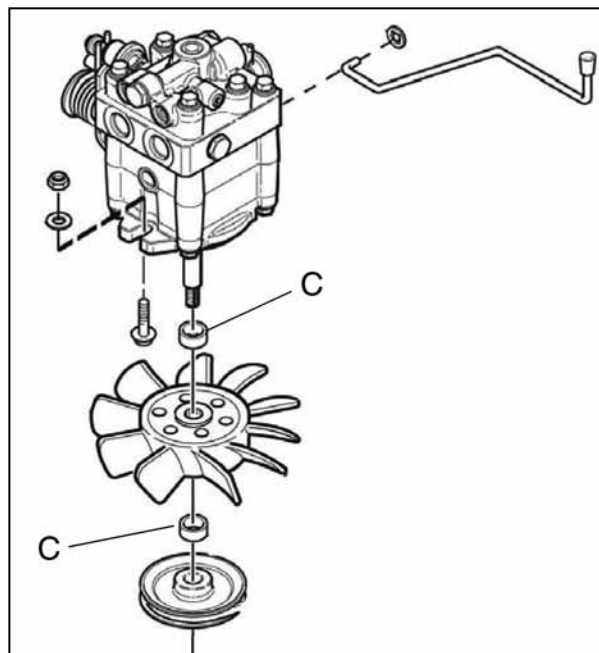

2.5 Steering cylinder

2.5.1 Dismantling

1. Block up the machine. Use a lifting table or highjack and yokes.
2. Activate the parking brake.
3. Dismantle all covers at the left side. See "Covers" page 5.
4. Block up the front left wheel and remove it to get access to the front cylinder attachment.
5. Place a collecting tray under the steering servo for collecting residual oil from the hoses.

 **Warning! Do not spill any oil on the drive belts during the disconnection of hoses and tubes.**

 **Warning! Keep clean when handling hydraulic parts. Dirt in the oil will cause malfunctions and breakdowns.**

6. Dismantle the hose collecting bar (A).
7. Loosen the cylinder hoses (B) from the steering servo.
8. Remove the screws holding the steering cylinder and take out the cylinder with hoses.
9. Note the angle of the hoses and remove them from the cylinder. Fit the hoses in the same angle to the new cylinder.

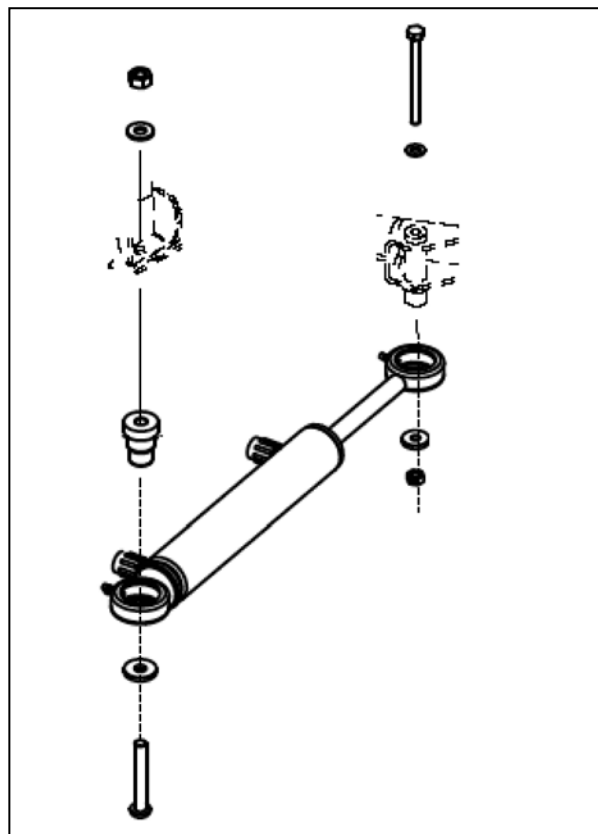

2.5.2 Assembly

1. All the assembly is performed in the reverse order.
2. After the assembly, start the machine and turn the steering wheel fully left and fully right several times until the steering works properly.
3. Check the hydraulic oil and fill up as necessary. See the owners manual.

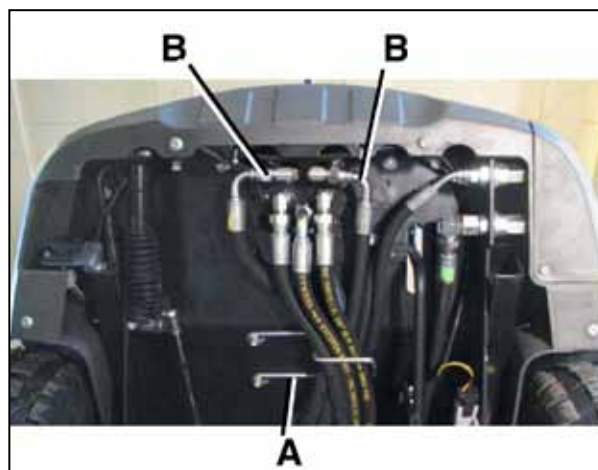

2.6 Articulating point

2.6.1 Dismantling

1. Block up the machine. Use a lifting table or highjack and yokes.
2. Activate the parking brake.
3. Dismantle all covers from the art. point. See "Covers" page 5.
4. Turn the steering wheel max to the left and loosen the rear steering cylinder attachment.
5. Work off the belts from the art. point pulley, unscrew the lower screw and remove the pulley from its shaft.

 **Warning! Check that the frames are securely supported while they are separated.**

6. Support the front and rear frame close to the art. point with two hydraulic jack or similar.
7. Unscrew the upper screw and press the shaft downwards and separate the frames.
8. Move the rear frame sideways until it comes free from the fork.
9. Press out the two spheric plain bearings from the rear frame. Use a mandrel if necessary.

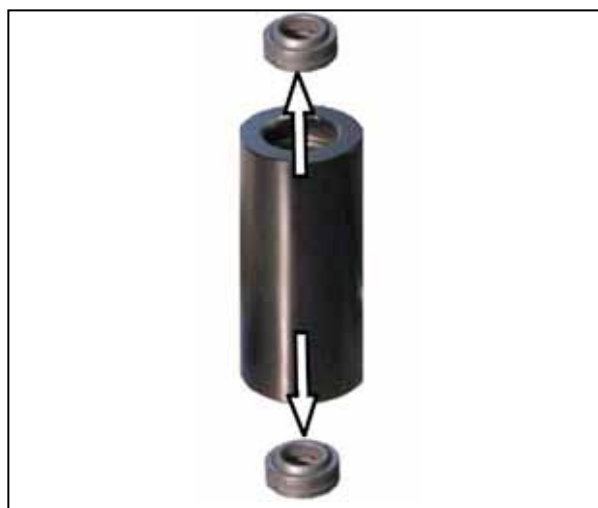
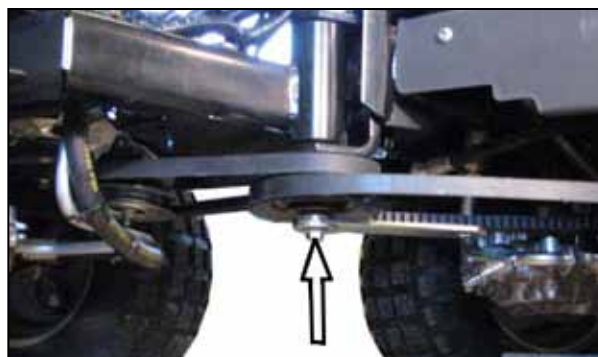

2.6.2 Assembly

1. All the assembly is performed in the reverse order.
2. Note the support sleeve between the spheric plain bearings,
3. Lubricate the spheric plain bearings before installation.

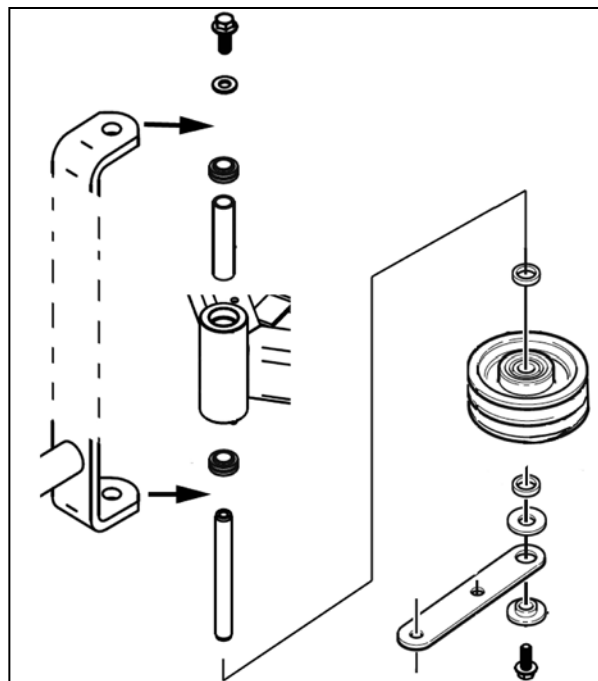

2.6.3 Replacing the yoke shaft

1. Apart the art. point as described in "Articulating point" page 15.
2. Use an angle grinder and cut the yoke shaft close to the rear bearing. See the figure.
3. Grind off the painting from the rear part of the shaft and pull out the pieces backwards.
4. Turn the front part of the shaft until the dowel can be forced out and dismantle the parts.
5. The new yoke shaft is assembled in the reverse order.
6. Note that the bearing surfaces shall be lubricated before installation.

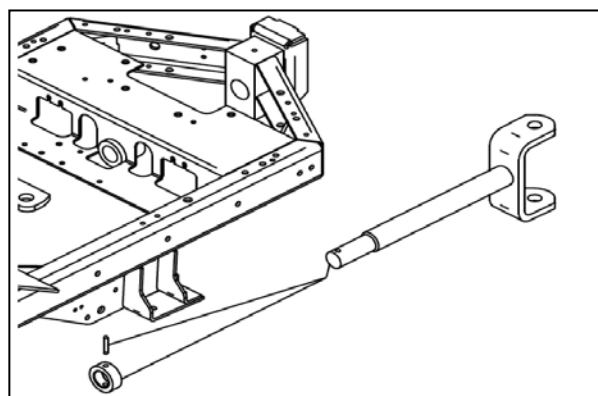

2.7 Front transmission shafts repair method

The ends of the front transmission shafts can wear down to the point where they lose most of their functionality, usually due to lack of greasing of the RAC quick coupling or use of the machine in particularly dusty conditions.

A repair kit (code 387001019/0), shown in the figure, has been prepared to overcome this problem, where the worn ends of the shafts can be restored without having to replace the entire transmission unit.



It is essential to carry out all the steps in the following repair procedure carefully.

1. Lift and stabilise the front part of the machine.

 **Warning! Engage the parking brake and place two wedges behind the rear wheels to prevent the machine from moving.**



2. Remove the lock ring (1) and RAC (2).



3. Remove the washer (3).



4. Remove the three nuts (4) and the wheel (5).



5. Mark the position of the aluminum hub (6) on the transmission shaft (7).

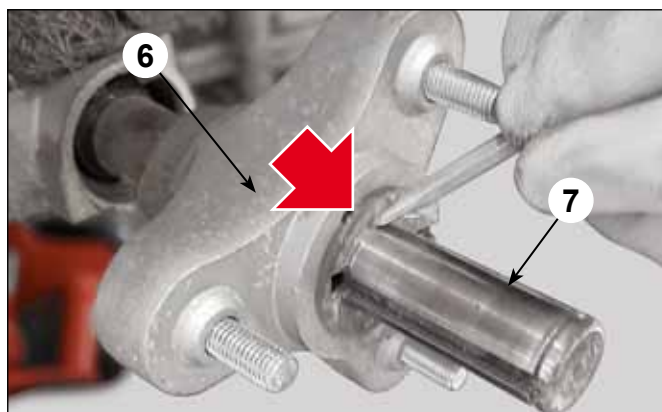

6. Remove the aluminum hub (6) by unscrewing the two screws (8).

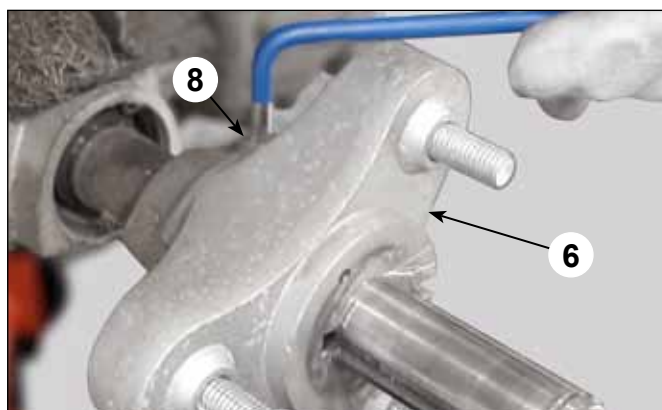

7. Using a hammer, remove the three screws (9) from the aluminum hub (6) and replace them with the new three screws M10x40.

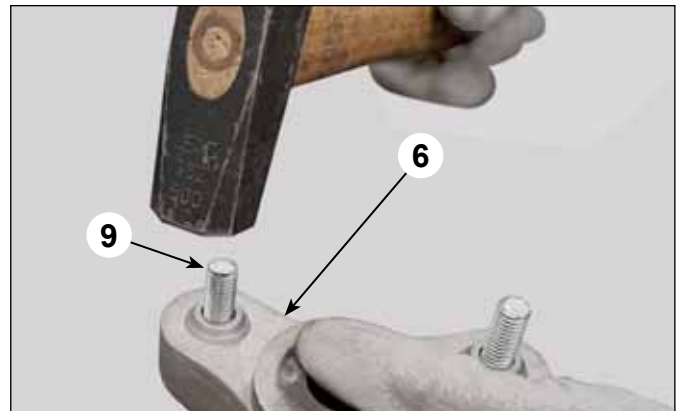

8. Cut the shaft (7) of the transmission at the marked point, trying to make a perpendicular cut.

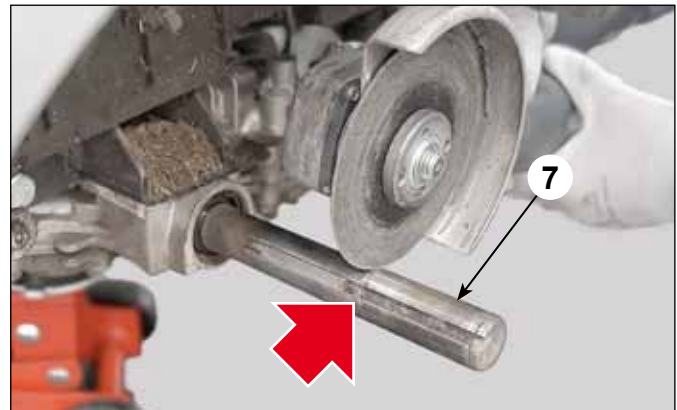

9. With a file, remove burrs from the transmission shaft (7).

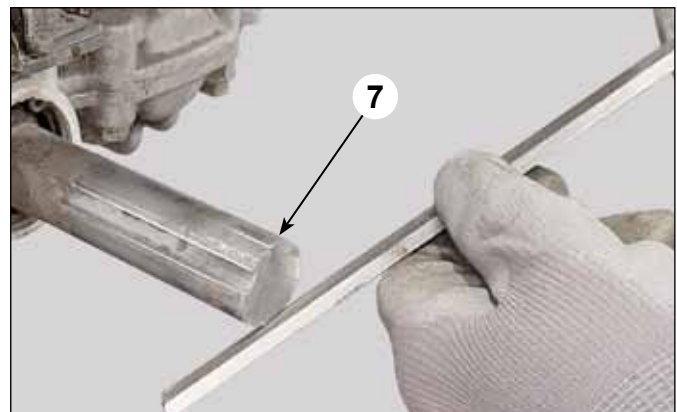

10. Fit the aluminum hub in position (6) and tighten the screws with a torque of 20÷25 Nm



11. Fit the wheel (5).



12. Fit the new axle support (11) and tighten the three nuts (12) with a torque of 35÷50 Nm.



13. Fit a new washer (13).



14. Fit the RAC (2).



15. Fit another new washer (13).



16. Fit a new lock ring (14).



17. When the installation of the kit is finished on this side of the machine, repeat the procedure also on the opposite side.



18. Lubricate both quick connections through the nipples, using a grease gun until grease penetrates along the shaft.



3 - Steering

Contents in this chapter

3.1 Description.....	2
----------------------	---

General

The machines are equipped with hydraulic assisted steering system, type "Orbitrol".

This chapter contains only a brief description of the complete configuration of the steering system.

A deeper description of the hydraulics is given in section 4.



3.1 Description

The hydraulic pump (A) feeds the steering servo (B) with an oil pressure. The steering servo adjust the oil flow to and from the respective side of the steering cylinder (C).

Thus the steering cylinder push or pull the left side of the frames, bringing them to set in a desired angle.

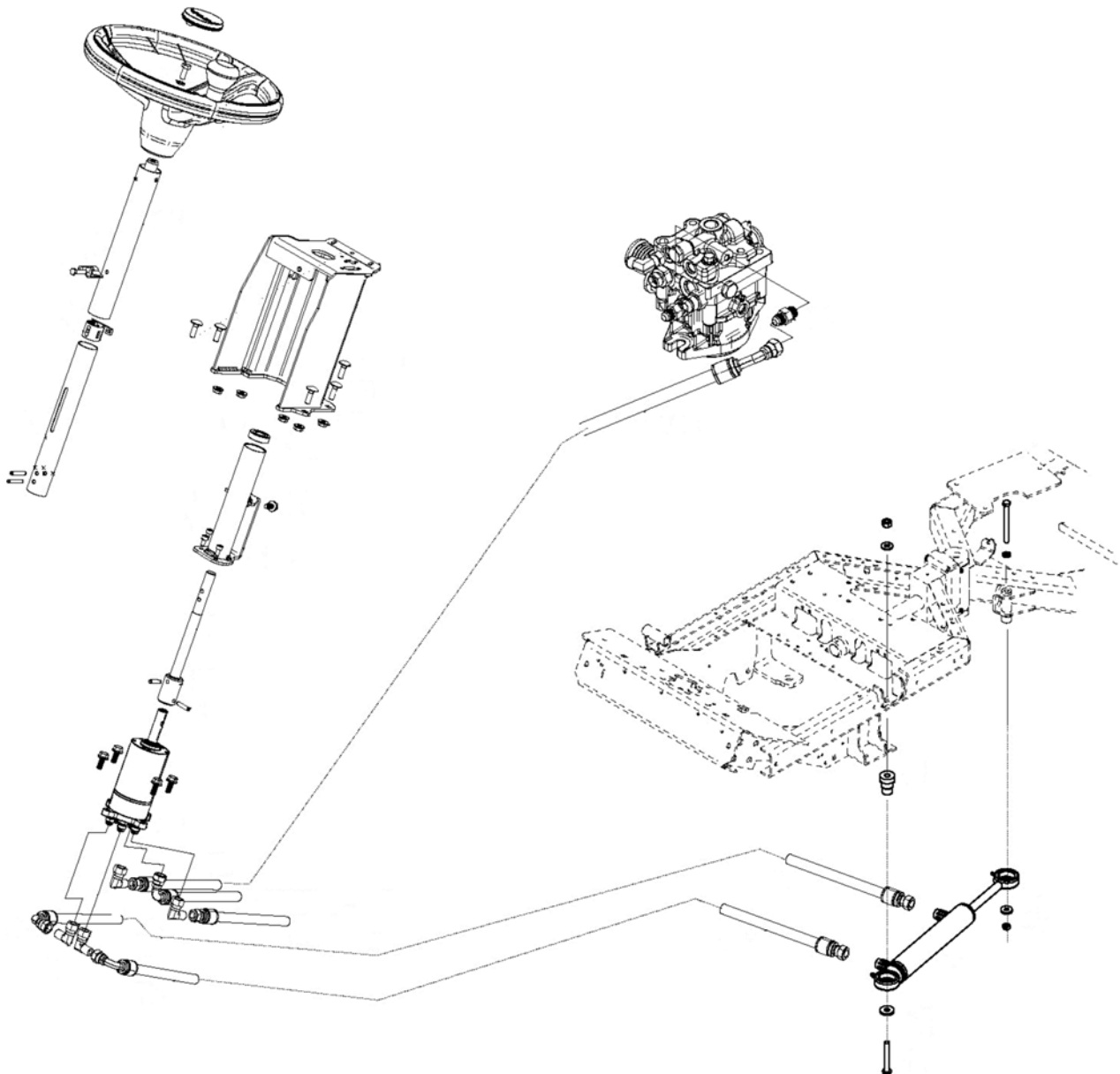

4 - Hydraulic system

Contents in this chapter

4.1 Safety	2	4.5.1 Physic description.....	13
4.2 Configuration	2	4.5.2 Functional description.....	15
4.3 Power transmission	3	4.5.3 Removing the hydraulic distributor.....	20
4.3.1 Physical description.....	3	4.5.4 Hydraulic distributor servicing.....	22
4.3.2 Functional description.....	4	4.6 Trouble shooting	28
4.4 Hydraulic steering	7	4.6.1 Drive system.....	28
4.4.1 Physic description.....	7	4.7 Auxiliary hydraulic	30
4.4.2 Functional description.....	9	4.8 Change of transmission oil	32
4.5 Hydraulic implement lifter and hydraulic outputs	13		

General

The four wheel drive Park machines are equipped with hydraulic power transmission. I.e. the engine drives an hydraulic pump, which pumps oil through the rear and front axle drives. The hydraulic pump is separate located in front of the engine.

The front axle and rear axle are connected in series, which means that the front wheels and rear wheels are forced to rotate at the same speed. To make turning easier, both axles are equipped with a differential.

The machines are also equipped with hydraulic assisted steering and implement lifter. Front-mounted implements are powered via drive belts.

This chapter contains a description of the hydraulic system, trouble shooting to isolate faults and information about adjustments and corrective measures.



4.1 Safety

Hydraulic oil under pressure can be very dangerous if hoses, lines or other distribution parts are leaking. To avoid personal injuries, always wear protection gloves and protection goggles during works with the hydraulic system.

Before starting the motor, place the machine outdoors or install an extraction device for the exhaust fumes. Otherwise the personnel will be poisoned.

Cleanliness is mandatory at all works with the hydraulic system. Foreign substances and contaminations will jeopardize the function and reliability of the system. Always protect and close openings of hoses, lines and connections when replacing components.

4.2 Configuration

The machines are equipped with Hydraulic steering where the force is transferred to the frames by a hydraulic cylinder. See "Hydraulic steering" at page 7.

The power transmission, the hydraulic assisted steering, implement lifter and the hydraulic connections (Aux1 and Aux2) work with the same oil, but in separate parallel systems. Therefore, the descriptions are divided in the following headings:

The following sections will explain the physical arrangement of the hydraulic components and give a functional description.

4.3 Power transmission

4.3.1 Physical description

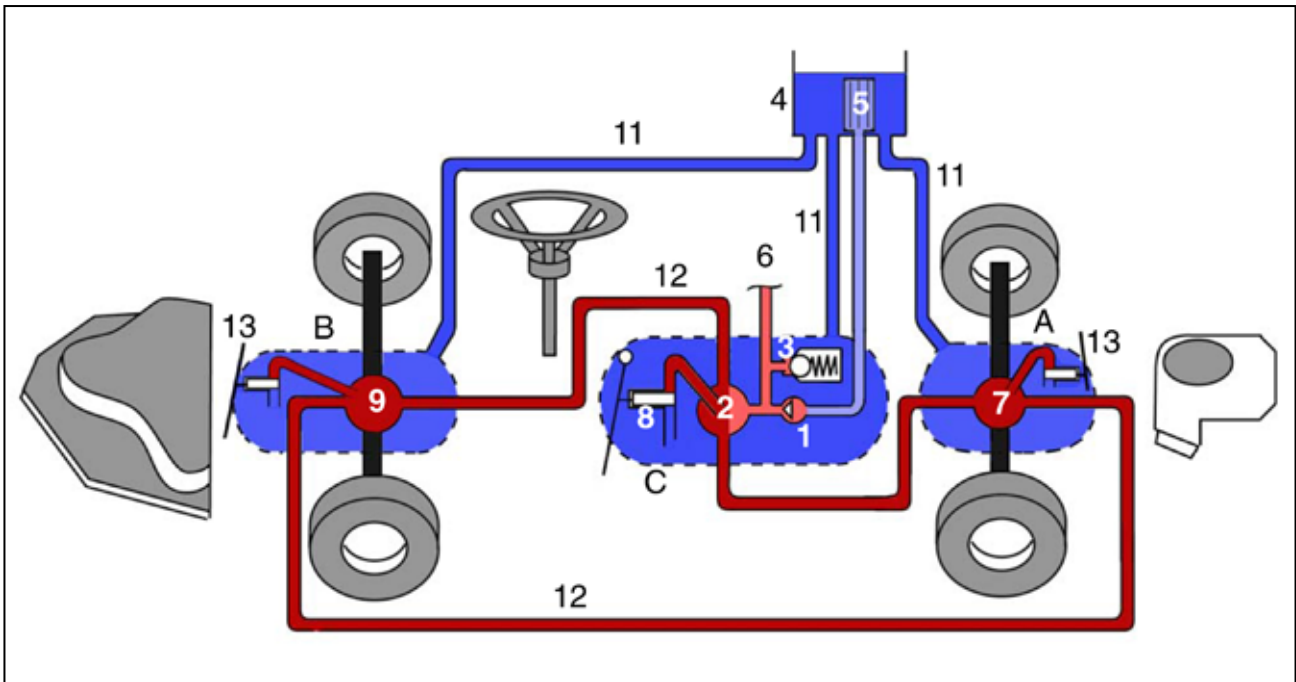

- | | |
|--|---|
| <p>A. Rear axle drive with its hydraulic motor (7).</p> <p>B. Front axle drive with its hydraulic motor (9).</p> <p>C. Hydraulic pump. The parts 1-3 and 8 below are positioned in the hydraulic pump.</p> | <p>9. Hydraulic motor in the front axle drive (B).</p> <p>11. Leak flow lines.</p> <p>12. Main flow lines.</p> <p>13. By-pass valve (only used when oil change)</p> |
|--|---|

1. Charge pump, max 55 bar
2. Main pump.
3. Pressure relieve valve for the charge pressure.
4. Oil tank.
5. Oil filter.
6. Connection to the auxiliary hydraulics (steering valve and implement lifter).
7. Hydraulic motor in the rear axle drive (A).
8. By-pass valve in the hydraulic pump (C).

Colour -Pressure

- Red is the feeding pressure to the main pump and to the auxiliary hydraulics.
- Dark red is the working pressure to the hydraulic motors.
- Blue is the atmospheric pressure in the oil tank and housings.
- Light blue is below the atmospheric pressure (pump)

The charge pump (1) and the main pump (2) are integrated into one unit, the hydraulic pump (C) which is located separat in front of the engine.

The engine drives the the hydraulic pump (C) with a constant speed. The charge pump (1) is feeding the main pump (2) with max 55 bar The oil, fed into the main pump during operation, is a replacement for the leak oil from the front and rear axle drives (A and B) and the main pump (2).

The charge pump sucs its oil from the oil tank (4) and through the filter (5).

The oil flow and the flow direction through the main pump (2) - front hydraulic motor (9) - rear hydraulic motor (7) is controlled by the speed pedal, mechanical connected to the main pump (2). The main pump pressure is depending on the power requirements at the wheel axles and is limited by the engine power.

The hydraulic motors and the hydraulic pump have a small oil leakage (1-4%), which increases with increased power requirement (increased pressure). The leakage oil is collected inside the unit housings an forwarded back to the oil tank through the leak flow lines.

The motors are connected in serie with the rear hydraulic motor (7) first, when driving forwards. This means, due to the leakage in the rear motor, that the machine under normal conditions drives on the rear wheels only. When the rear wheels begin to slip (rotate with 1-4% higher speed than the front wheels) also the front wheels start to drive and the slipping is avoided. This fact is not noticed by the operator, since the machine is driven with its four wheels after demand.

By-pass valve

The main pump (2) is equipped with a bypass valve (8), connected to its clutch release lever. When the by-pass valve is open, the main pump is disconnected from the oil circuit by an open passage out into the housing.

The pressure drop over the pump is such neutralized and the oil can flush free in the system. See the figure.

The by-pass valve is intended to make it possible to push the machine without heavy resistance from the main pump.

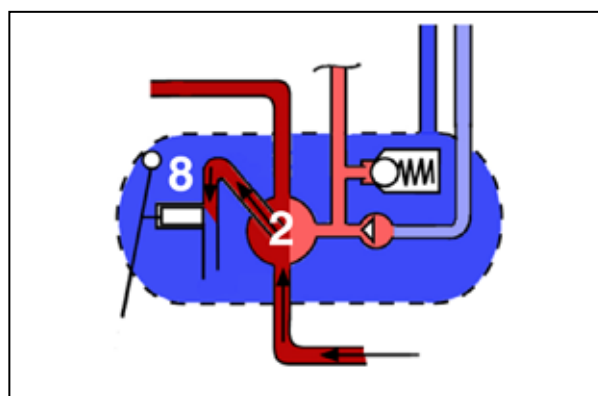
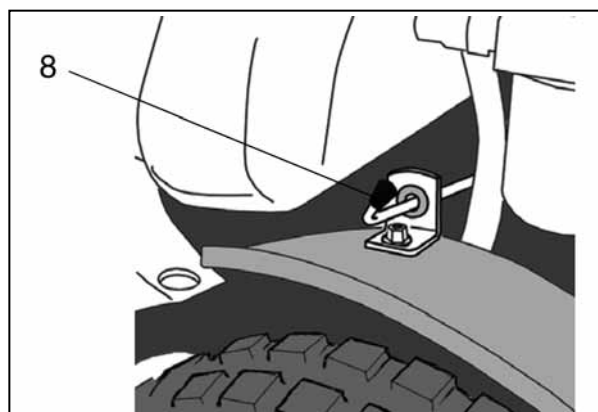

Charge pump

The charge pump has two tasks:

- To feed the auxiliary hydraulic with max 55 bar
- To feed the main pump with its initial pressure, 1,5-2,5 bar.

Auxiliary hydraulic

The charge pump (1) sucks oil from the oil tank (5).

When the auxiliary hydraulics are in use, the pressure in the out line (3) is limited to 35-45 bar by the relief valve (4)..

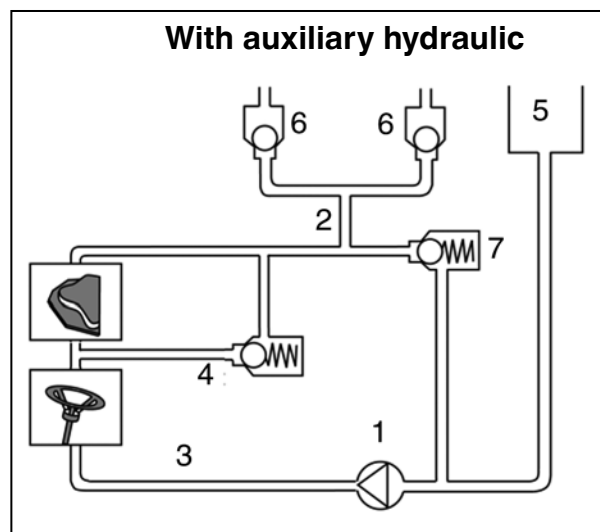

Feeding the main pump

The line (2) feeds oil to the main pump respective suction lines (depending on driving forwards or backwards) through the respective back valves (6). The pressure in the line (2) is limited to 1,5-2,5 bar by the relief valve (7).

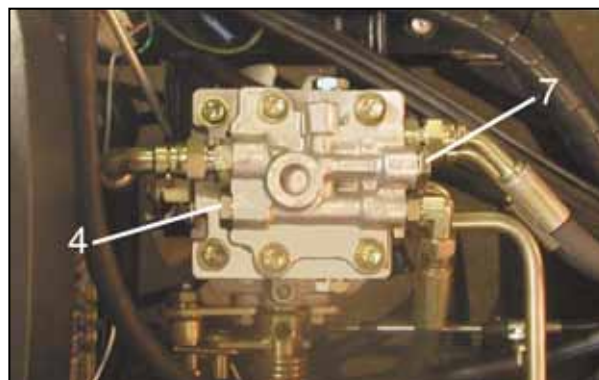

4.4 Hydraulic steering

4.4.1 Physic description

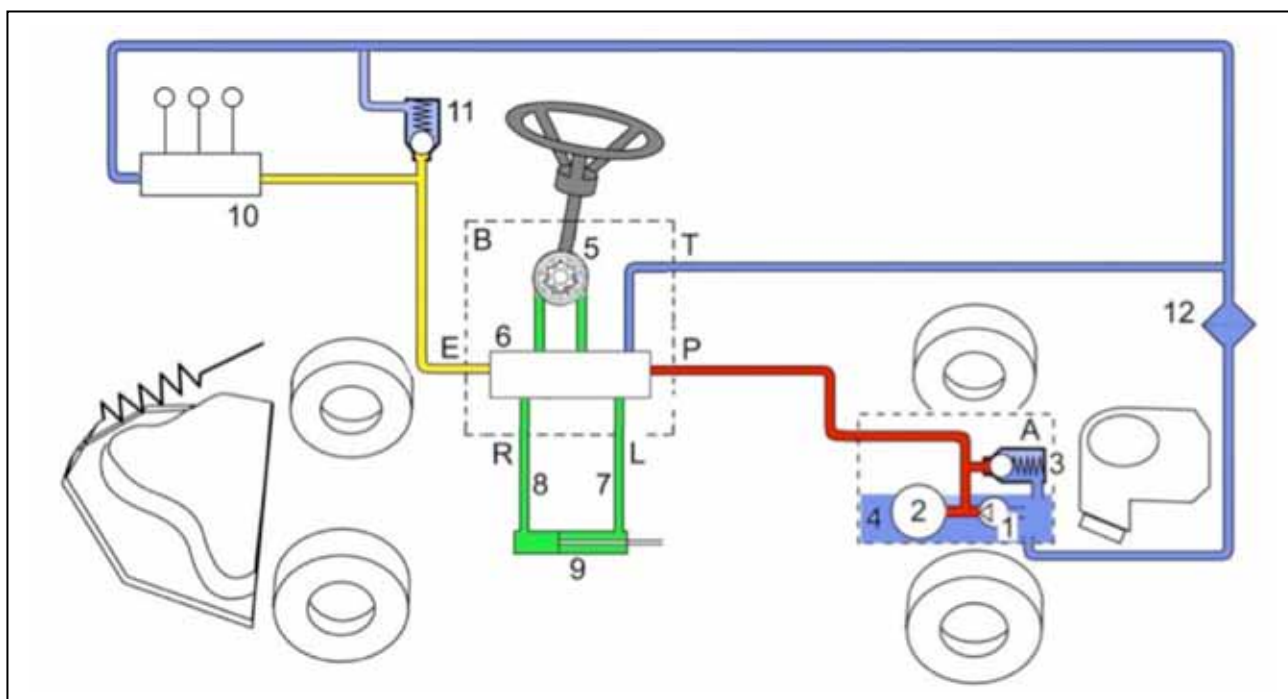

- A. Hydraulic pump. The parts 1-3 below are positioned in the hydraulic pump.
1. Charge pump, 49-51 bar.
 2. Main pump.
 3. Pressure relieve valve for the charge pressure.
 4. Oil tank
- B. Steering valve including the following:
5. Gear
 6. Distributor

Terminals at the steering valve:

- P. Inlet from the hydraulic pump for auxiliary hydraulics.
- T. Outlet to the tank for leak oil and oil from the passive side of steering cylinder when turning.
- E. Outlet to other auxiliary hydraulics.
- L. Outlet to the steering cylinder. Pressure when turning left.
- R. Outlet to the steering cylinder. Pressure when turning right.

- 7, 8. Pressure lines to transmit the steering power.
9. Steering cylinder.
10. Auxiliary hydraulics.
11. Pressure relieve valve 31-33 bar.
12. Filter.

Colour - Pressure

- █ Red is the feeding pressure to the steering valve and auxiliary hydraulics.
- █ Yellow is the feeding pressure to auxiliary hydraulics connected after the steering valve.
- █ Blue is the atmospheric pressure in the oil tank and lines.
- █ Green lines can act both as pressure lines and return lines, depending on the movements

B. Steering valve

The steering valve is a complete unit. The steering valve transmits the oil flow to the auxiliary hydraulics. The valves in the steering valve are not adjustable. The steering valve has 5 hydraulic terminals. The following items are included in the steering valve:

5. Oil pump

The oil pump has two purposes:

- To activate the steering cylinder when no hydraulic pressure is present (motor not running)
- To transmit the high pressure oil to the steering cylinder (motor is running)

6. Distributor

The distributor consists of a number of valves, which are controlled by the actuating of the steering wheel.

9. Steering cylinder

The steering cylinder is connected to the front and rear frame at the right side of the machine. By expanding respectively retracting it brings the frames to angle into desired directions.

11. Pressure valve

The pressure relief valve shall ensure that the back pressure of the steering valve is limited to 31-33 bar. This became the maximal pressure to the remaining auxiliary hydraulics. These facts ensure that the steering valve always works properly, even when the auxiliary hydraulics is overloaded.

12. Filter

The filter is located on the return line from the auxiliary hydraulics. This means that all the oil from the auxiliary hydraulics passes the filter. The filter has a cleaning degree of 10 micron.

4.4.2 Functional description

Not turning, steering wheel not actuated

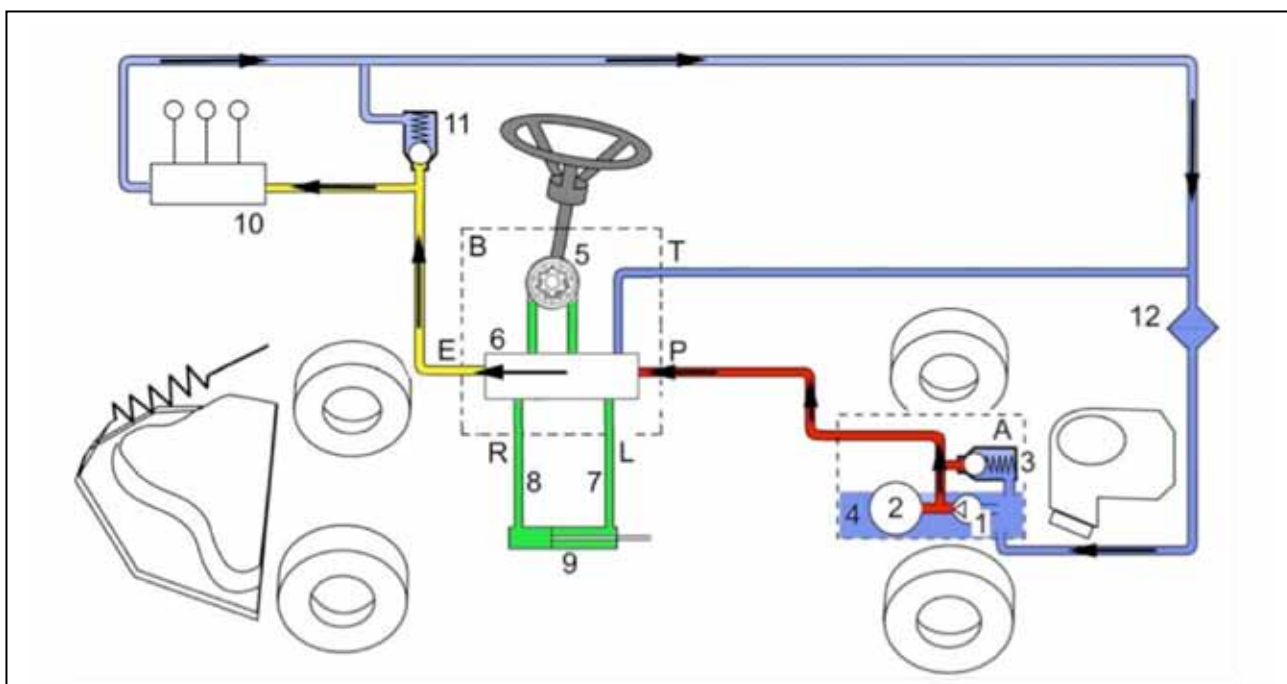

- A. Hydraulic pump. The parts 1-3 below are positioned in the hydraulic pump.
1. Charge pump, 49-51 bar.
 2. Main pump.
 3. Pressure relieve valve for the charge pressure.
 4. Oil tank
- B. Steering valve including the following:
5. Gear
 6. Distributor
 - 7, 8. Pressure lines to transmit the steering power.
 9. Steering cylinder.
 10. Auxiliary hydraulics.
 11. Pressure relieve valve 31-33 bar.
 12. Filter.

Colour - Pressure

- Red is the feeding pressure to the steering valve and auxiliary hydraulics.
- Yellow is the feeding pressure to auxiliary hydraulics connected after the steering valve.
- Blue is the atmospheric pressure in the oil tank and lines.
- Green lines can act both as pressure lines and return lines, depending on the movements

The charge pump (1) is sucking oil from the tank and pumping it into the steering valve. Since the steering is not in use, the oil flows without resistance through the steering valve, distributor and to the remaining auxiliary hydraulics. From the auxiliary hydraulics, the oil is flowing back to the tank via the filter (12).

Turning to the left

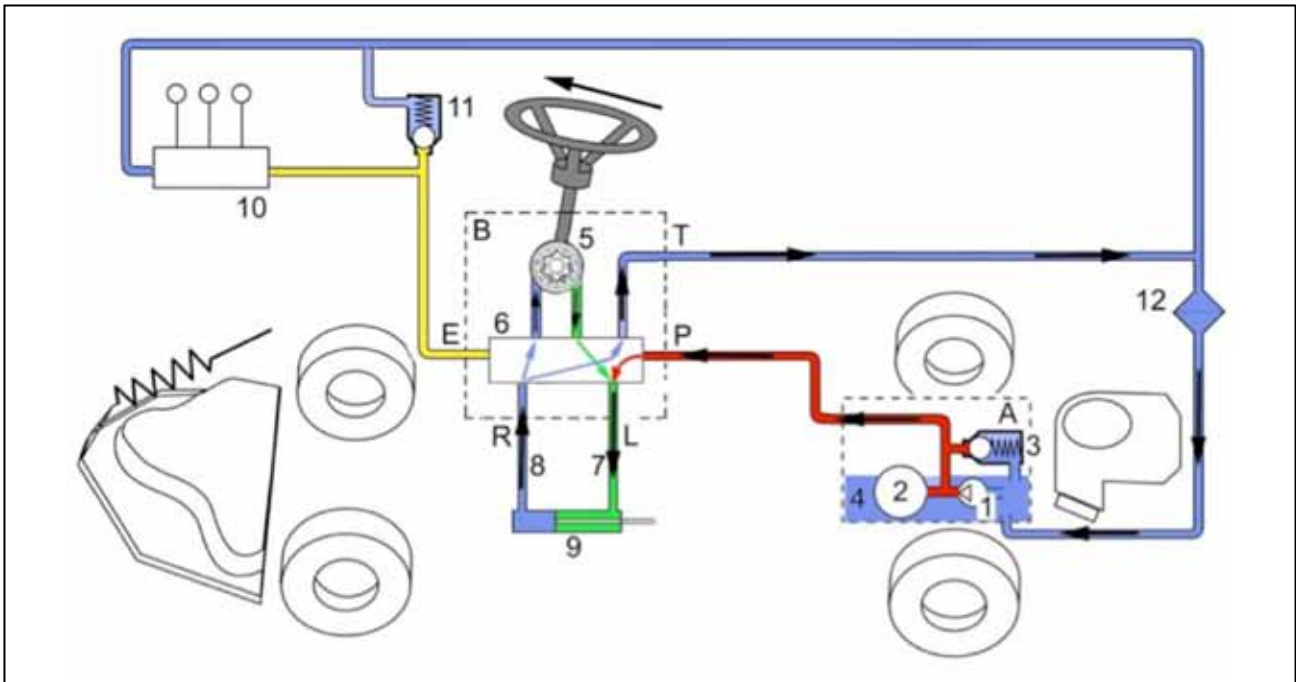

- A. Hydraulic pump. The parts 1-3 below are positioned in the hydraulic pump.
 - 1. Charge pump, 49-51 bar.
 - 2. Main pump.
 - 3. Pressure relieve valve for the charge pressure.
 - 4. Oil tank
- B. Steering valve including the following:
 - 5. Gear
 - 6. Distributor
 - 7, 8. Pressure lines to transmit the steering power.
 - 9. Steering cylinder.
 - 10. Auxiliary hydraulics.
 - 11. Pressure relieve valve 31-33 bar.
 - 12. Filter.

Colour - Pressure

- Red is the feeding pressure to the steering valve and auxiliary hydraulics.
- Yellow is the feeding pressure to auxiliary hydraulics connected after the steering valve.
- Blue is the atmospheric pressure in the oil tank and lines.
- Green lines can act both as pressure lines and return lines, depending on the movements.

The distributor (6) consists of a number of valves, which are controlled by the actuating of the steering wheel. Since the entire steering valve (B) is an unrepairable spare part, the exact function of these valves are not explained in this description. Only the oil flows through the unit is presented in order to explain the system function.

Turning to the right

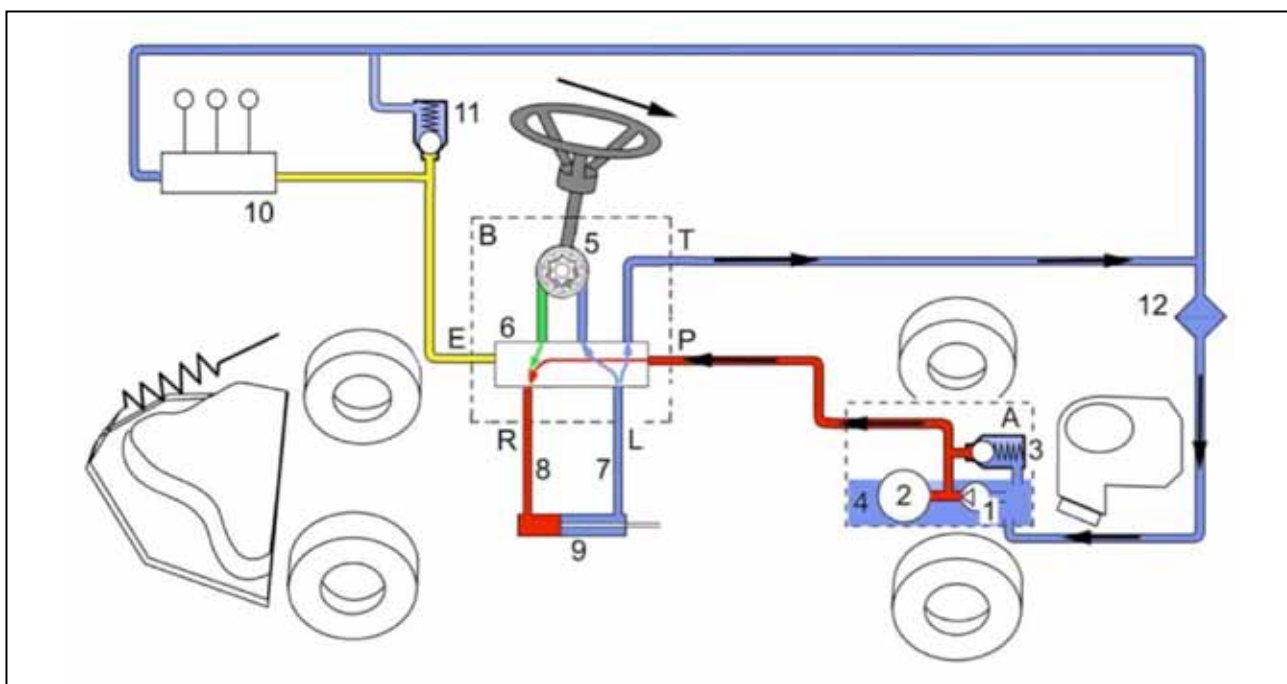

- A. Hydraulic pump. The parts 1-3 below are positioned in the hydraulic pump.
1. Charge pump, 49-51 bar.
 2. Main pump.
 3. Pressure relieve valve for the charge pressure.
- B. Steering valve including the following:
5. Gear
 6. Distributor
 - 7, 8. Pressure lines to transmit the steering power.
 9. Steering cylinder.
 10. Auxiliary hydraulics.
 11. Pressure relieve valve 31-33 bar.
 12. Filter.

Colour - Pressure

- █ Red is the feeding pressure to the steering valve and auxiliary hydraulics.
- █ Yellow is the feeding pressure to auxiliary hydraulics connected after the steering valve.
- █ Blue is the atmospheric pressure in the oil tank and lines.
- █ Green lines can act both as pressure lines and return lines, depending on the movements

The distributor (6) consists of a number of valves, which are controlled by the actuating of the steering wheel. Since the entire steering valve (B) is an unrepairable spare part, the exact function of these valves are not explained in this description. Only the oil flows through the unit is presented in order to explain the system function.

Turning with motor stopped

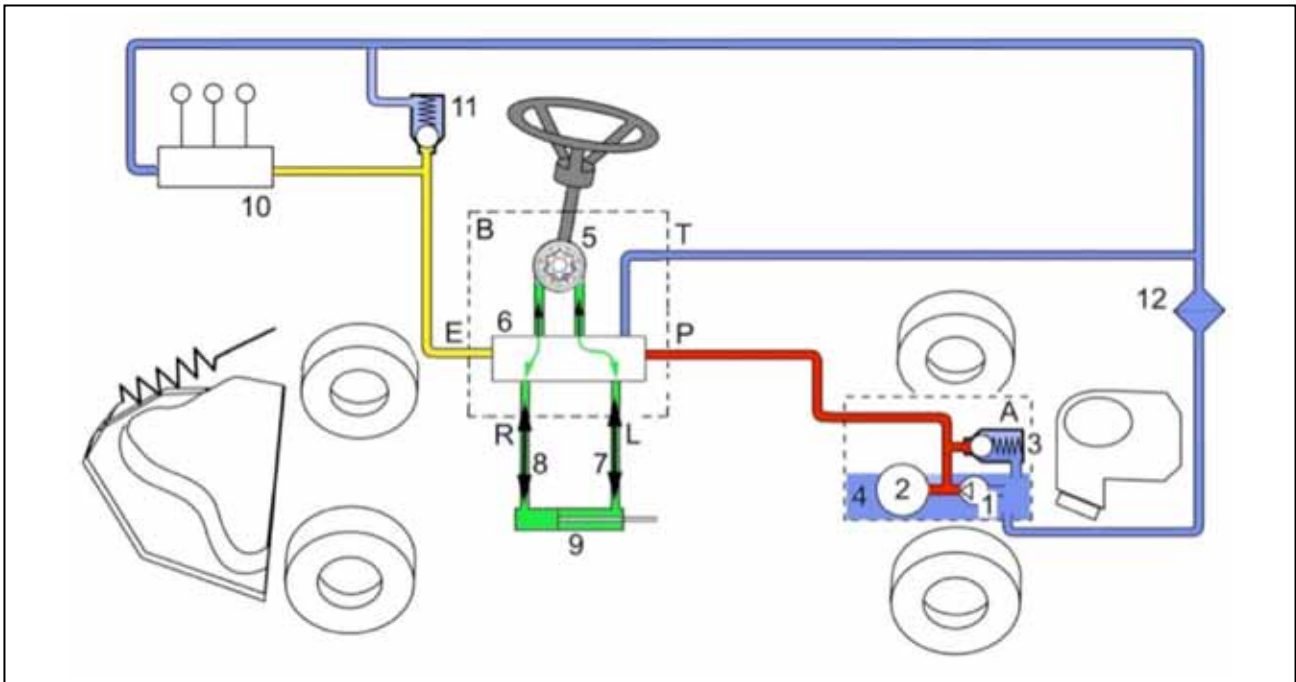

- A. Hydraulic pump. The parts 1-3 below are positioned in the hydraulic pump.
1. Charge pump, 49-51 bar.
 2. Main pump.
 3. Pressure relieve valve for the charge pressure.
- B. Steering valve including the following:
5. Gear
 6. Distributor
 - 7, 8. Pressure lines to transmit the steering power.
 9. Steering cylinder.
 10. Auxiliary hydraulics.
 11. Pressure relieve valve 31-33 bar.
 12. Filter.

Colour - Pressure

- Red is the feeding pressure to the steering valve and auxiliary hydraulics.
- Yellow is the feeding pressure to auxiliary hydraulics connected after the steering valve.
- Blue is the atmospheric pressure in the oil tank and lines.
- Green lines can act both as pressure lines and return lines, depending on the movements

When using the steering wheel with the motor stopped (no oil pressure), the oil flows between the cog wheel pump (5) and the steering cylinder (9) only. All other oil flows are cut off.

4.5 Hydraulic implement lifter and hydraulic outputs

4.5.1 Physic description

The outputs and levers are shown below.

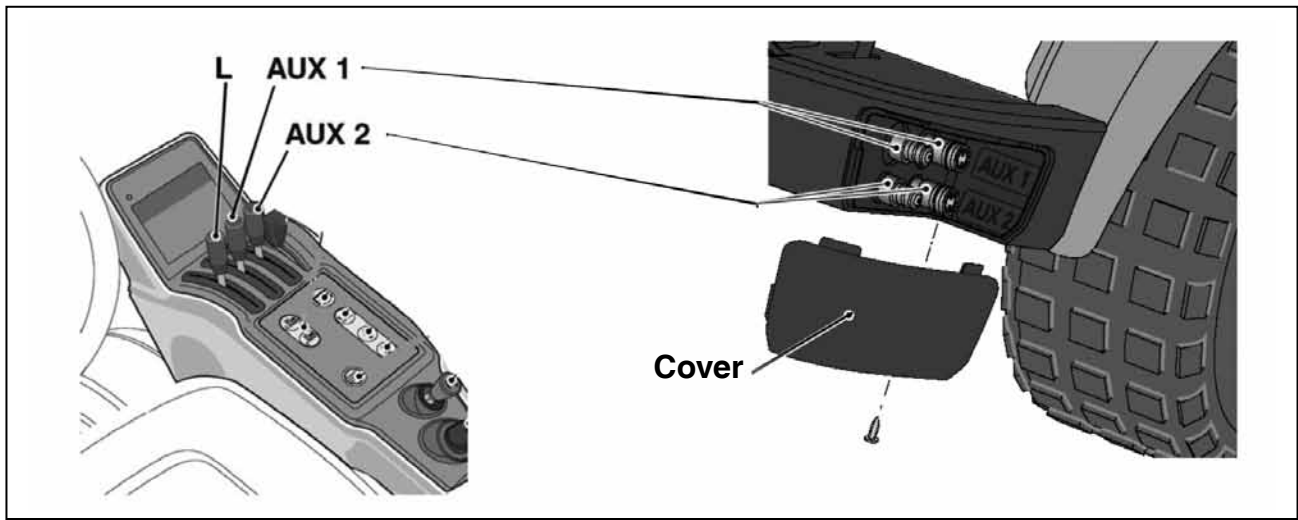

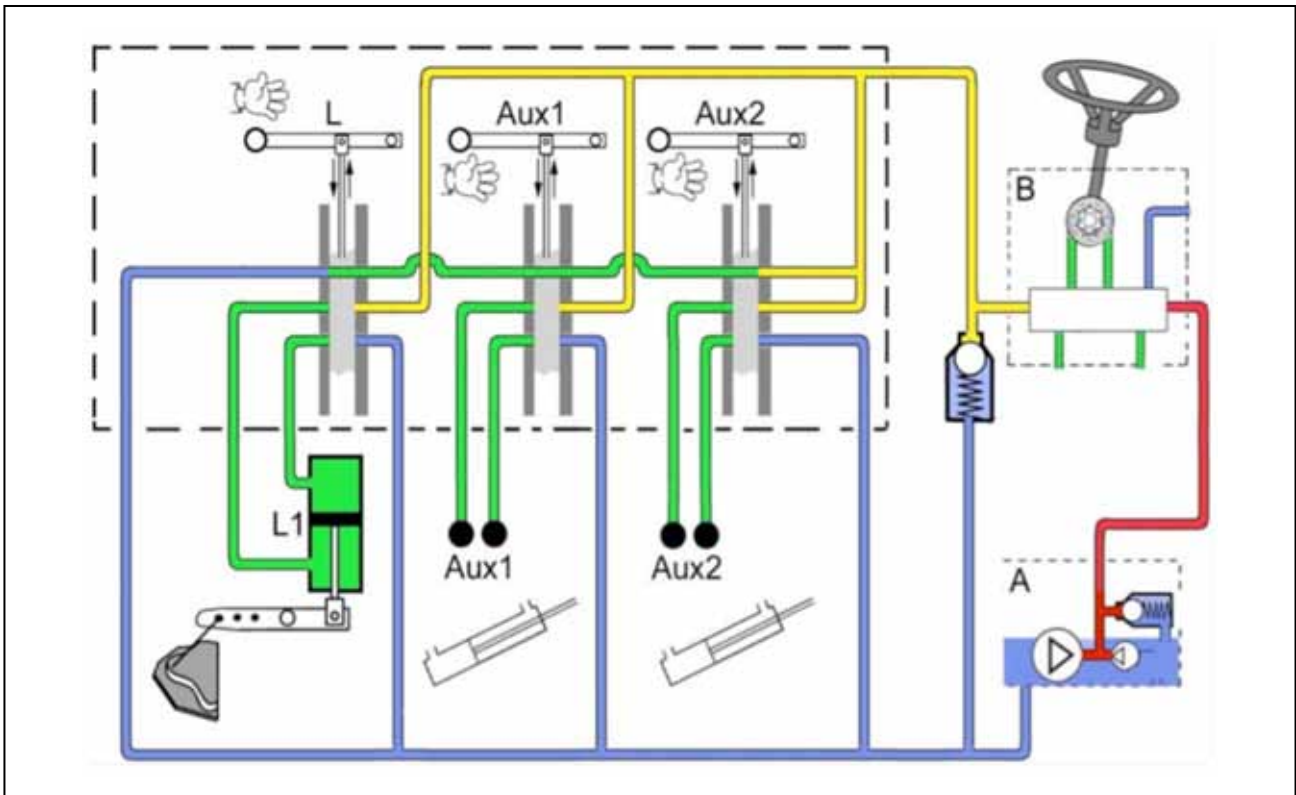

- A. Hydraulic pump.
- B. Steering valve.
- L. Control lever for the implement lifter.
- L1. Implement lifter cylinder.
- 11. Pressure relieve valve 31-33 bar.

Aux1 and Aux2:
Control levers for the actual hydraulic connectionsi.

Colour - Pressure

- Red is the feeding pressure to the steering valve and auxiliary hydraulics.
- Yellow is the feeding pressure to auxiliary hydraulics connected after the steering valve.
- Blue is the atmospheric pressure in the oil tank and lines.
- Green lines can act both as pressure lines and return lines, depending on the movements

4.5.2 Functional description

Auxiliary hydraulics not in use

Operation state:

- Motor is running in full speed.
- The steering wheel is not actuated.
- The implement lifter is not activated.

The hydraulic pump (A) is forcing oil through the steering valve (B), and the opened valves (Aux2, Aux1 and L).

The oil flow is indicated with arrows in the figure below. Since neither of the items are working, the resistance can be ignored and the pressure is very low (<1 bar).

In the normal condition, the lifting cylinder (L1) is locked in its set position, because no oil can flow out or in since the oil lines are shut by the slide.

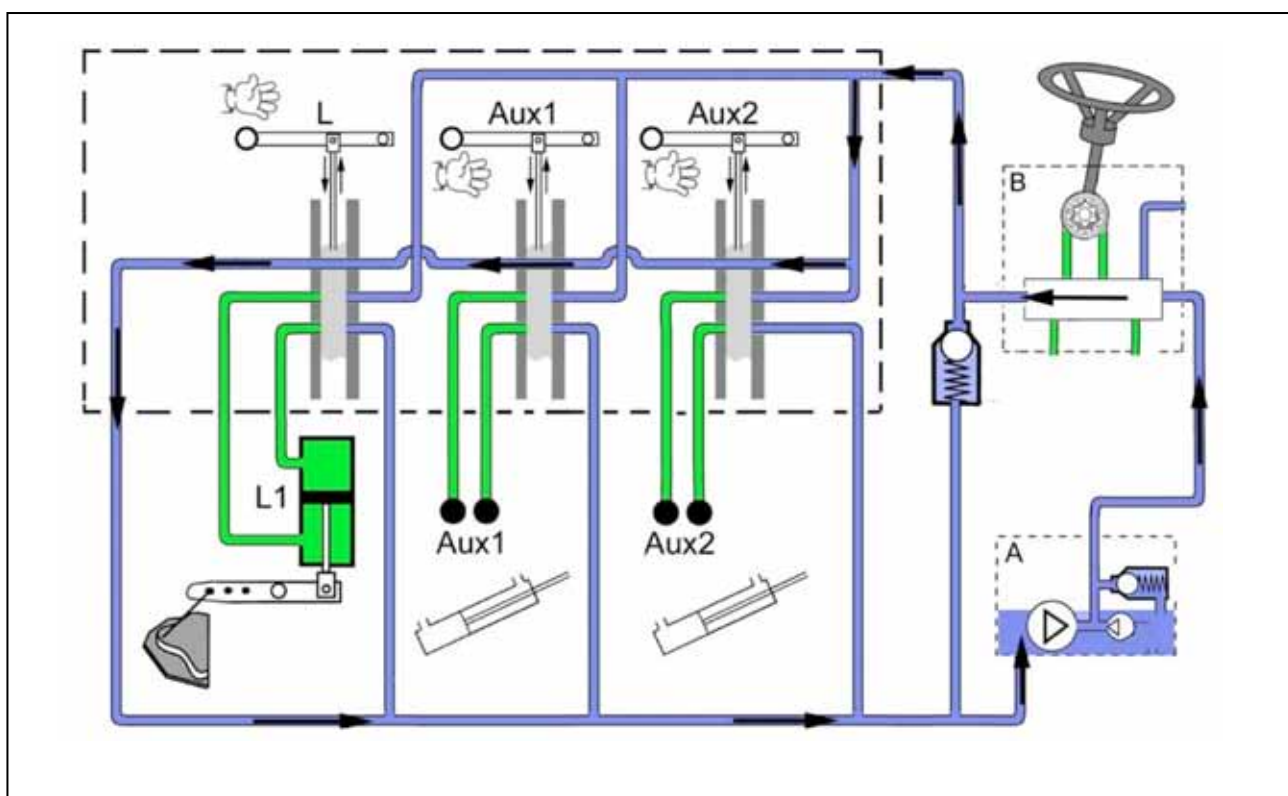

Implement lifter upwards

Operation state:

- Motor is running in full speed.
- The implement lifter is activated upwards.

The operator has actuated the hand lever (L) to its raising position, which moves the slide to change the hole pattern between the connections in the valve. The hole pattern is adapted for the raising procedure (crossed in the figure below). Oil forces through the slide and presses out the piston in hydraulic cylinder (L1).

When the piston in cylinder (L1) is fully extended and the hand lever still is activated, the oil will flow only through the valve (11) and a noise will be heard from the valve.

When the hand lever is released, valve will return to its neutral position and the system switches over to its normal state. The piston in the hydraulic cylinder (L1) is then locked in its actual position.

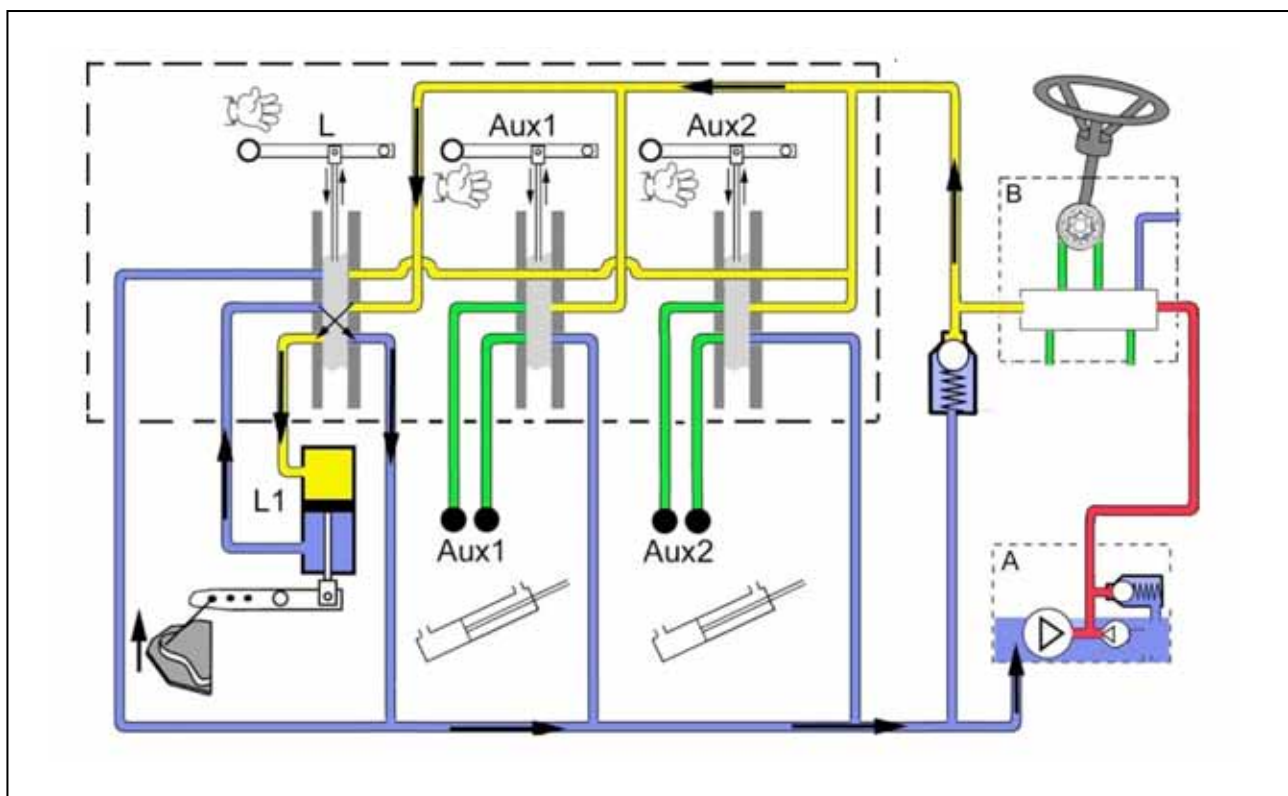

Implement lifter downwards

Operation state:

- Motor is running in full speed.
- The implement lifter lever is activated downwards.

The operator has actuated the hand lever (L) to its lowering position (one step forwards), which moves the slide to change the hole pattern between the connections in the valve. The hole pattern is adapted for the lowering procedure. Oil forces through the slide and presses back the piston into the hydraulic cylinder (L1).

In this arrangement, the implement is forced down, irrespective its weight.

When the piston in cylinder (L1) has reached its bottom position and the hand lever still is activated, the oil will flow only through the valve (11) and a noise will be heard from the valve.

When the hand lever is released, the connected valve will return to its normal position and the system switches over to its normal state. The piston in the hydraulic cylinder (L1) is then locked in its actual position.

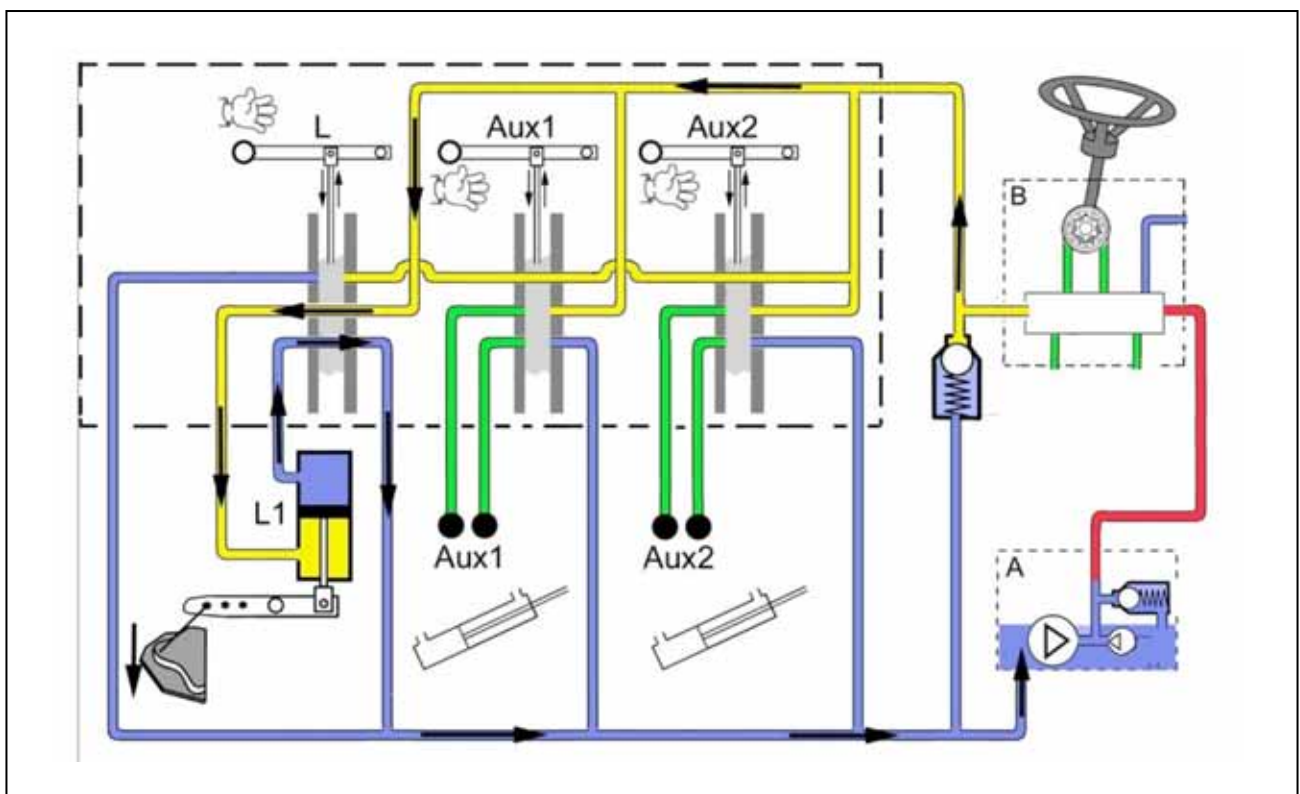

Floating position

Operation state:

- Motor is not running or is running in full speed.
- The implement lifter is in its floating position.

The operator has actuated the hand lever (L), to its floating position (locked in front position) which moves the slide to change the hole pattern between the connections in the valve. The hole pattern is adapted for the floating status. Both sides of the lifting cylinder (L1) is connected to each other and to the return line in the slide. I.e. no pressure can reach any side of the cylinder. No oil pressure affects the cylinder. The main part of the oil is flowing between the upper part and the lower part of the cylinder. A smaller part is flowing between the oil tank and the cylinder due to the displacement of the piston rod. See the arrows in the picture below.

In the floating position, the implement always rests against the ground with the same force (the weight of the implement) and follows the contours of the ground.

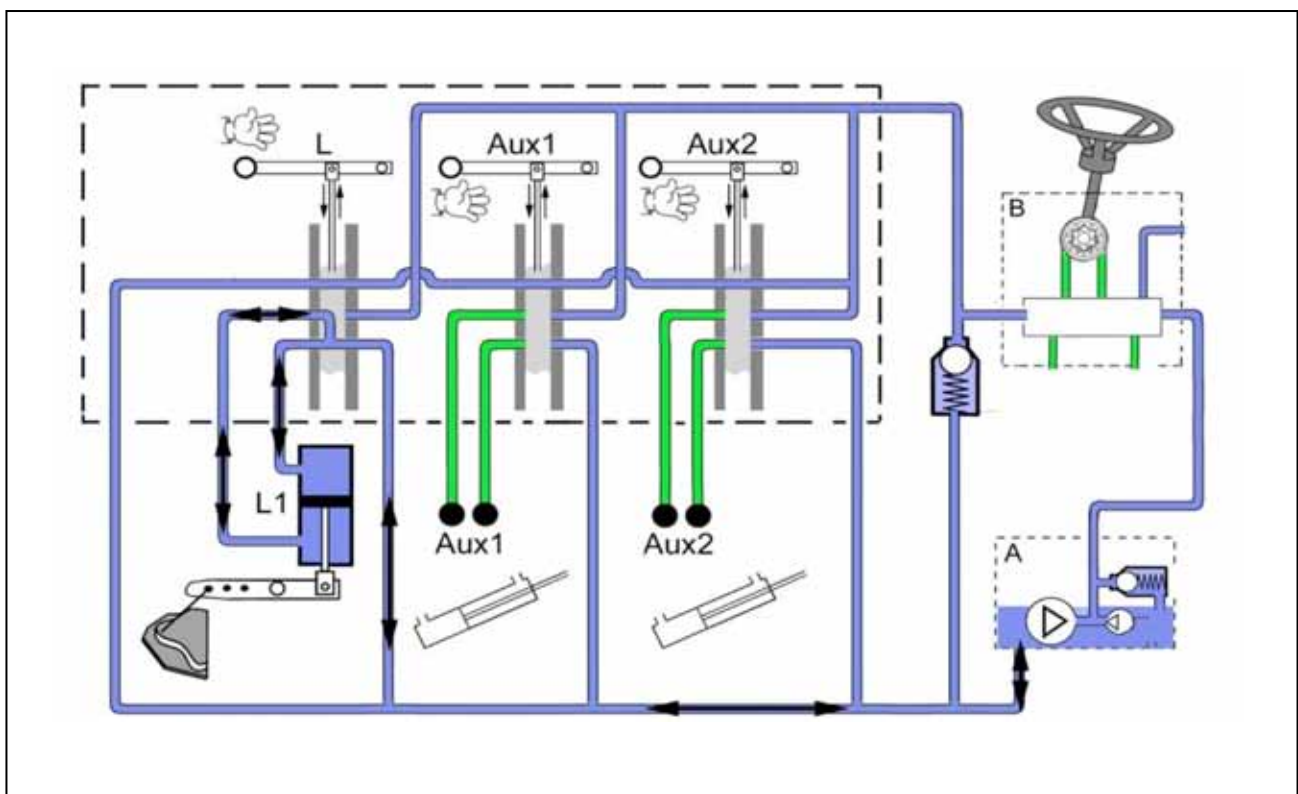

Hydraulic outputs Aux1 and Aux2

Operation state:

- Motor is running.

The hydraulic outputs Aux1 and Aux2 have the same function. The purpose of the outlets is to make some adjustments/settings in a connected implement.

The outputs can be set in the following three positions:

- Oil flow in direction A. E.g. the cutting height in a connected cutting deck is raised.
- Oil flow in direction B. E.g. the cutting height in a connected cutting deck is lowered.
- Oil flow is shut (Off). E.g. the cutting height in a connected cutting deck is locked.

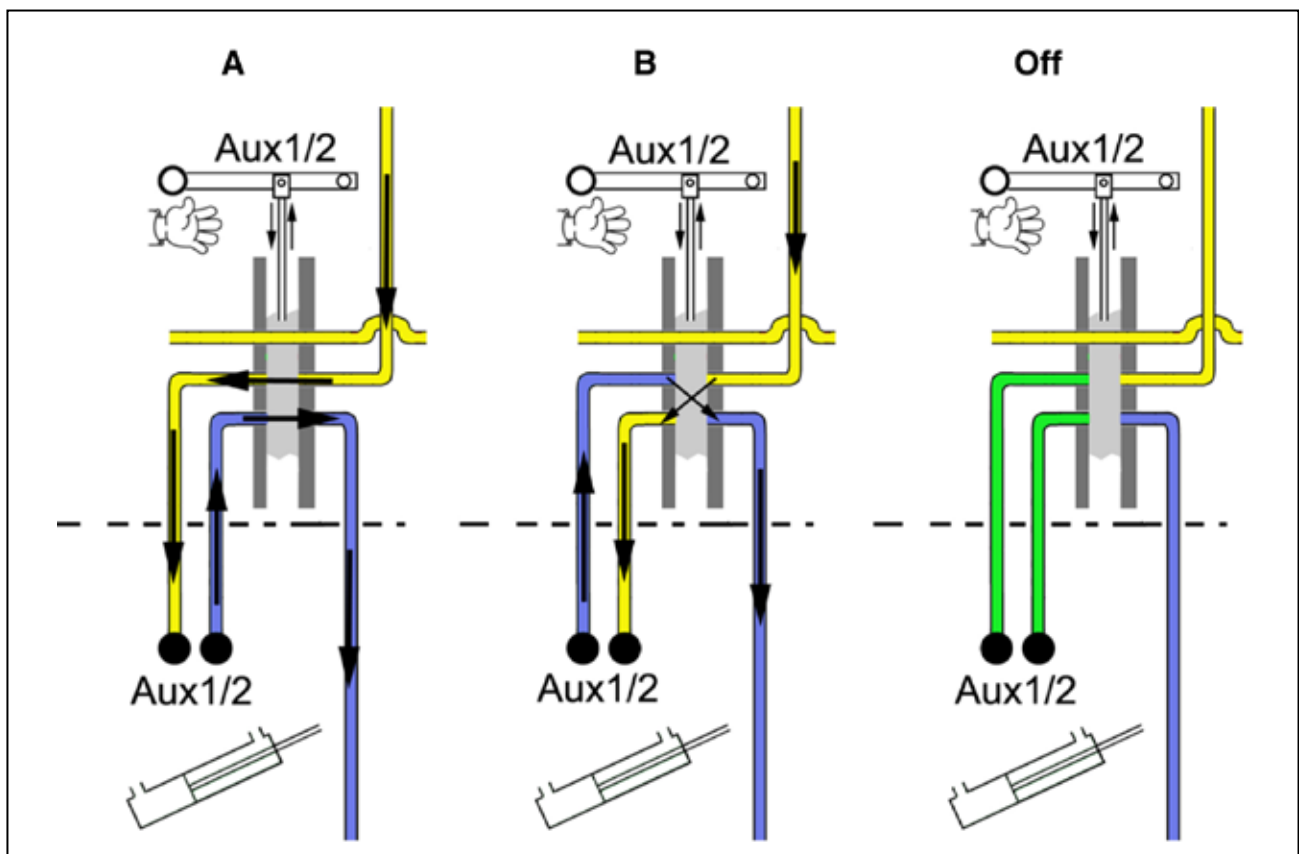

4.5.3 Removing the hydraulic distributor

Oil leaks from the hydraulic lift control valve are normally due to incorrect fitting of the O-rings or impurities that are lodged between the O-rings and their seats.

In this case, it is possible to remove the distributor from the machine, following the procedure below, and then remove the distributor to replace the seals, without having to replace the entire distributor. [see 4.5.4]



1. Remove the upper screw (1) securing the external panel in place (2)

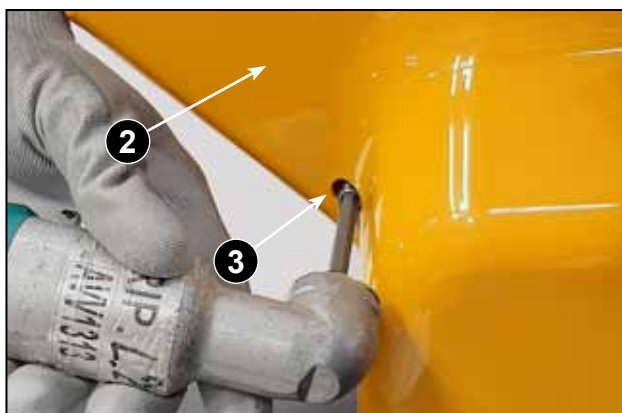

2. Undo the remaining five screws (3) securing the external panel in place (2).

3. Remove the external panel (2).



4. Undo the four screws (4) securing the internal panel in place (5).

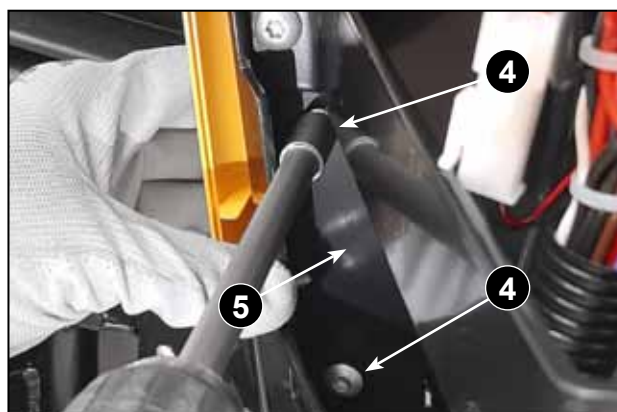

5. Lift the seat and remove the internal panel (5).

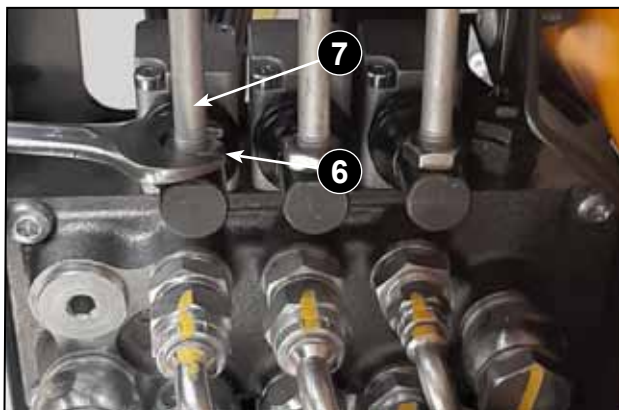

6. Loosen the nuts (6) securing the levers in place, unscrew the levers (7), remove the nuts and remove the levers from the upper panel



7. Mark each hydraulic pipe and each connector on the distributor (8) to ensure the correct position can be easily found when refitting them.

8. Undo the four screws (9) securing the lower metal casing (10) in place and remove the casing.

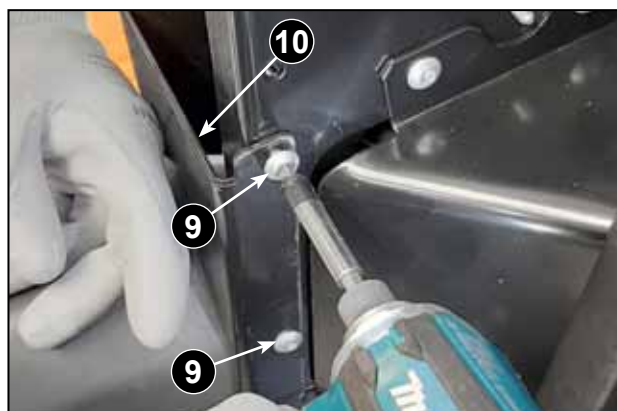

9. Cut the clamp (11).

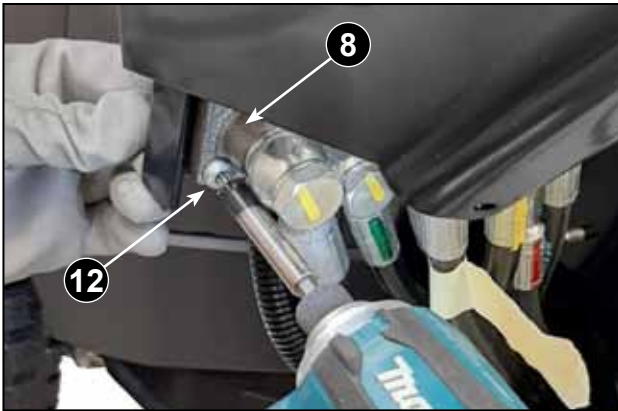

10. Undo the three screws (12) that secure the distributor (8) in place and then remove it.



11. Disconnect all hydraulic pipes, bearing in mind that only a small amount of oil will leak from the pipes.

- Reassemble the distributor on the machine, following the above instructions in the reverse order.
- When fully reassembled, top up the hydraulic oil and bleed any air from the system.

4.5.4 Hydraulic distributor servicing

- Remove the distributor from the machine [see 4.5.3].

! **Note!** The hydraulic distributor type can be one section (a) or three section (b); seal removal and replacement procedures 1 to 8 are the same for both types, whilst procedures 9 to 18 are specific operations for the three section type.

● Spare parts needed

For one section Hydraulic distributor p/n 187145001/0:

- 1 pc O-Rings p/n 118870328/0
- 1 pc O-Ring p/n 118870329/0

For three sections Hydraulic distributor p/n 187145000/1:

- 5 pcs O-Rings p/n 118870328/0
- 1 pc O-Ring p/n 118870329/0



● **Tools needed**

- a) 3 mm screwdriver or hex wrench.
- b) Hook screwdriver.

● **For one and three section Hydraulic distributor**

1. After removing the distributor (4) from the machine, operate strictly in clean conditions; in particular pay attention in not having foreign parts or dirt getting inside the oil port holes. The distributor can be cleaned, either by using compressed air or with brush and degreaser. Undo the two screws M4 for lever boxe (1) and slide out the PVC spacer (2) and the O-Ring (3).

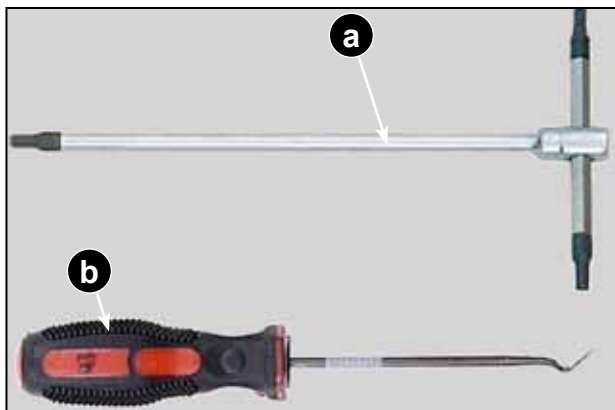

2. Remove the two screws M4 (5) that secure the positioner (6).

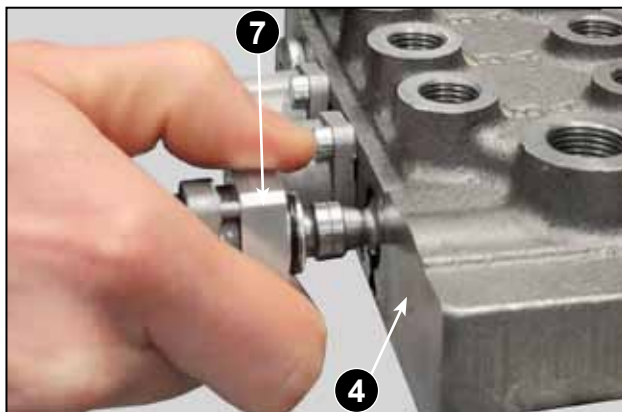
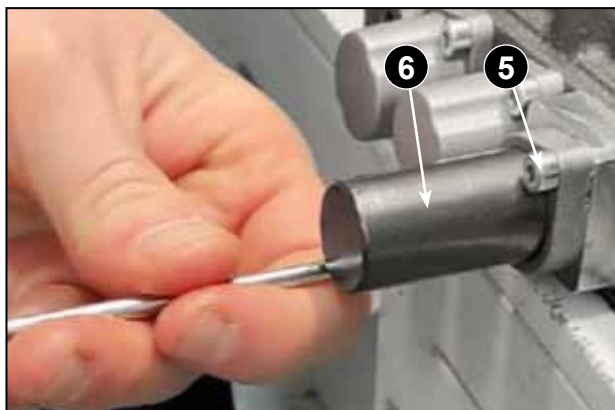
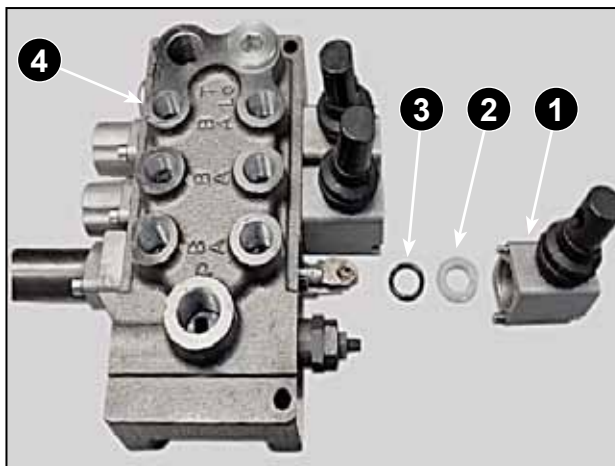

3. Remove the cursor (7) from the distributor (4), taking care to keep the whole assembly assembled to avoid damaging the internal gasket of the spacer.

4. Remove the O-Ring (8) with the help of a hooked screwdriver and carefully clean the O-Ring seat.

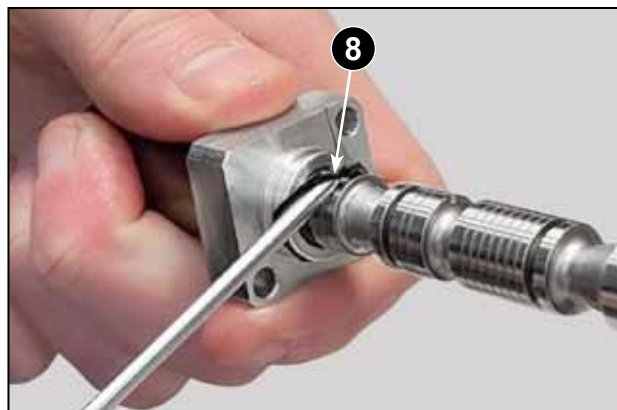

5. Assemble a new O-Ring (8).

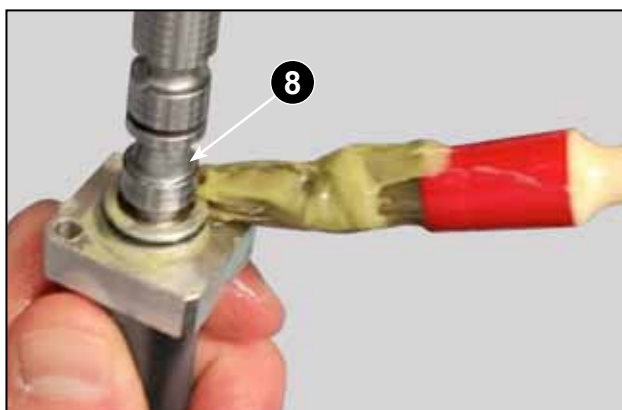

6. Apply a layer of grease all over the O-Ring.

7. Before proceeding, check that the spacer housing seat on the body is clean. Manually reinsert the spool (9) into the distributor (4).

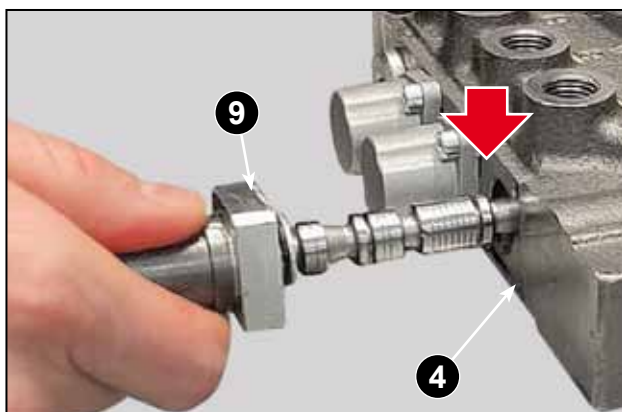

8. Bring the screws (10) to the stop and tighten them to the required torque of 3,8 Nm ($\pm 10\%$).



● **For three section distributors only**

The next points show the part about the two commands.

9. Unscrew the four screws M4 (11) from the two caps (12) of the commands.

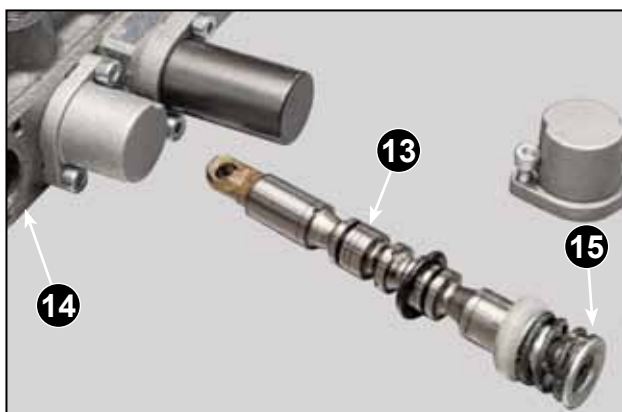
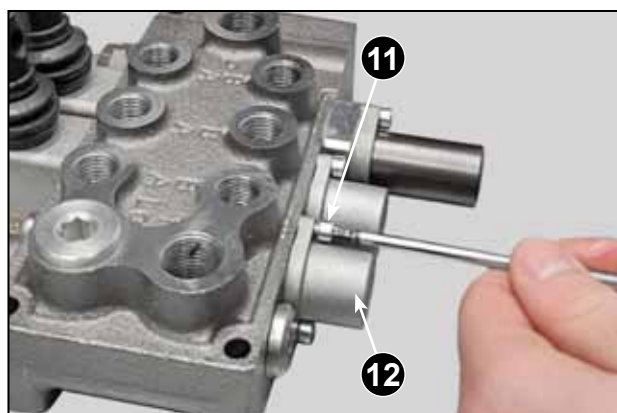

10. Remove the sliders (13) from the distributor (14) without removing the spring control (15).



11. Remove the O-Rings (16) from the sliders and clean the sliders and seal seats of the gasket in the distributor body.

12. Replace the O-Rings (16) with new ones.

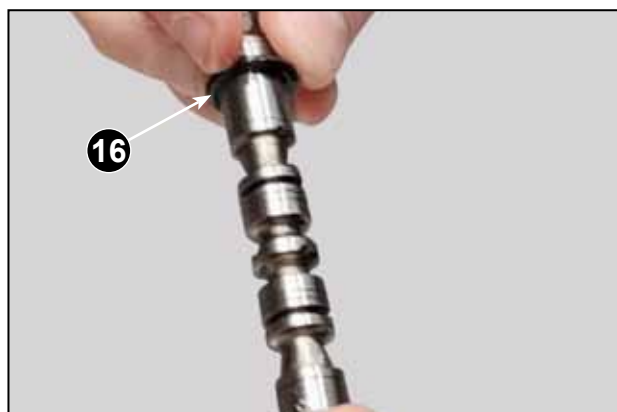

13. Manually reinsert the slider (13) into the distributor (14). If necessary, grease the spring control.

14. Reassemble the caps (12), bring the screws (11) to the stop and tighten them to the required torque of 2.7 Nm ($\pm 10\%$).

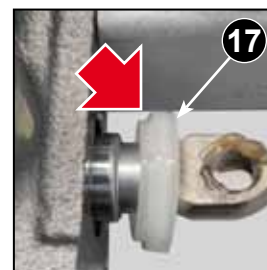
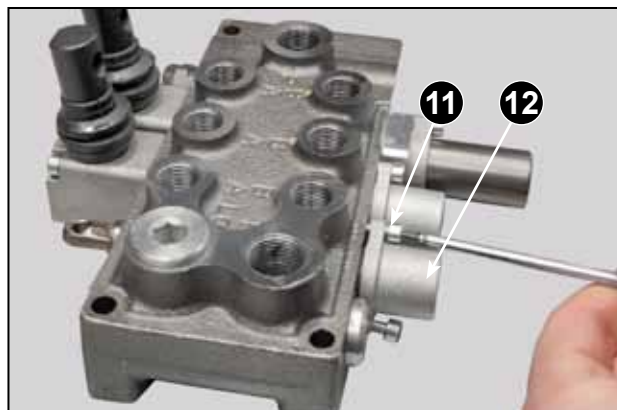

15. On the lever side, insert the new O-Rings and the PVC spacers (17) previously removed, with the turned lower diameter facing the distributor.

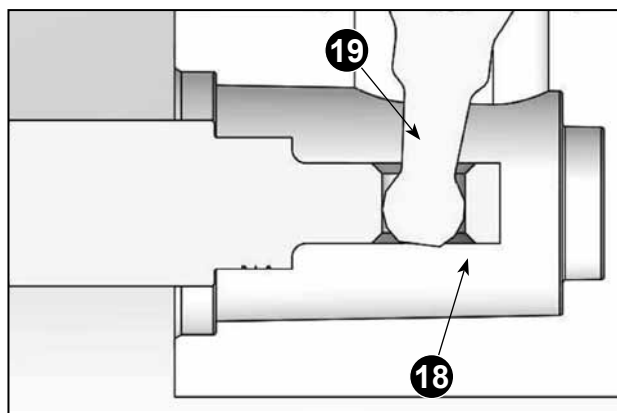
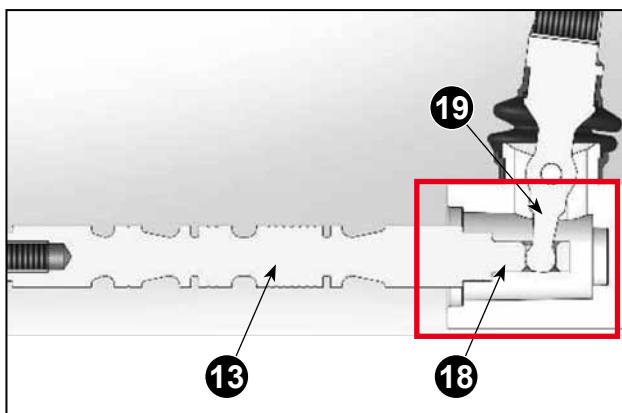

16. Grease the pens (18) of the slider (13) and reassemble the lever boxes, paying particular attention to correctly position the balls of the levers (19) in the eyelets of the slider pens as shown in the image.

17. Assemble the levers holder caps (20) as shown.

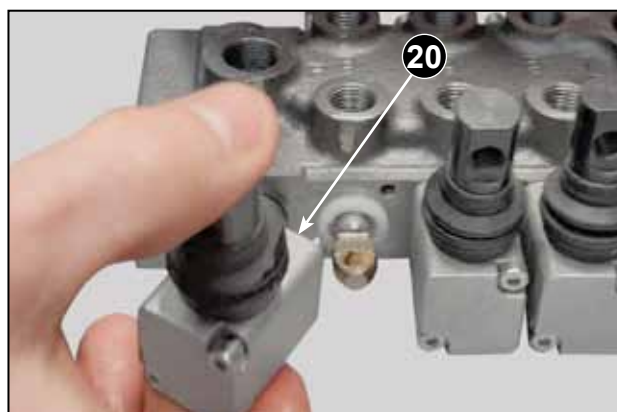

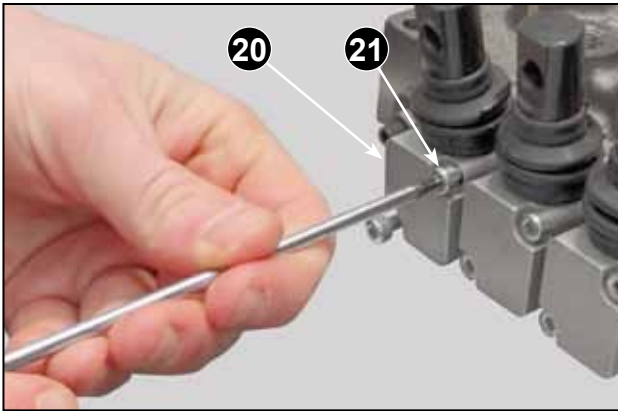

18. Bring the screws (21) home and tighten them to the required torque of 3.8 Nm (\pm 10%).

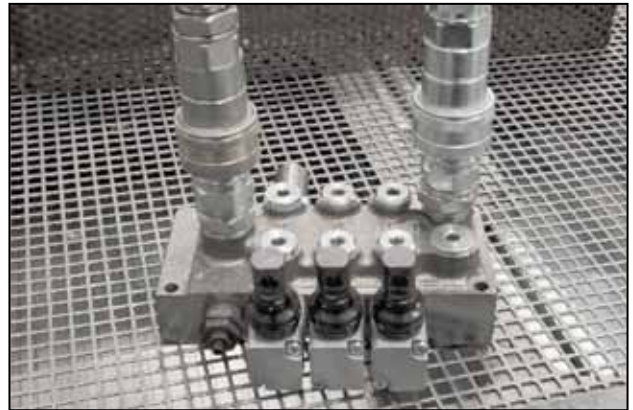

Before refitting the distributor, carry out a final test, on a bench, to check the correct hydraulic seal of the O-Rings.

4.6 Trouble shooting

Warning! Hydraulic oil under pressure can be very dangerous if hoses, lines or other distribution parts are leaking. To avoid personal injuries, always wear protection gloves and protection goggles during works with the hydraulic system.

4.6.1 Drive system

Before the trouble shooting takes place, it is provided that the following states are fulfilled:

- The axle by-pass valves are in drive position. See the figure..
- The clutch release levers shall be in the drive position. See the figures.
- Oil level in the oil tank as desired.
- No air in the hydraulic oil.

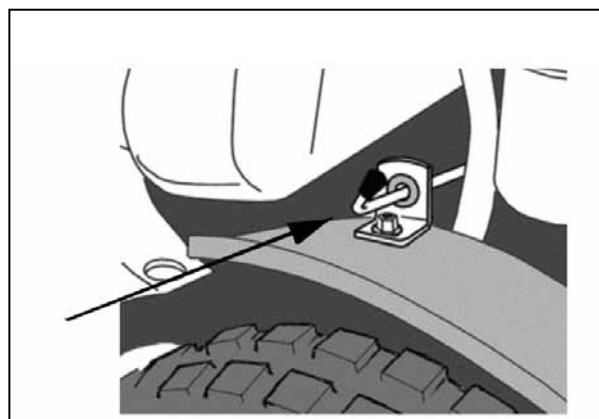
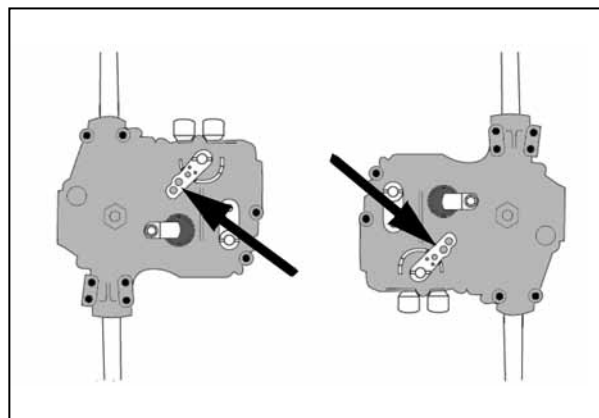

Symptom	Fault	Measure
The machine drives forwards but not backwards.	Front by-pass valve open.	Close the by-pass valve.
	Big leakage in the front axle drive.	Replace the front axle drive.
The machine drives backwards but not forwards.	Rear by-pass valve open.	Close the by-pass valve
	Big leakage in the rear axle drive	Replace the rear axle drive.
Reduced speed forwards and possibly faster backwards.	Speed control cable housing is moved.	Adjust the cable housing.
Reduced speed and uneven drive.	The suction filter (5) is clogged.	Clean the filter.
The front wheels don't drive.	One of the axle keys is broken.	Replace the actual key.
The rear wheels don't drive.	One of the axle keys is broken	Replace the actual key.
Reduced or no speed.	The belt between motor and pump is slipping.	Worn belt Replace the belt.
	Check if the fan and pulley at the pump rotate.	Maladjusted clutch wire- Adjust the wire.
	Big leakage in the hydraulic pump.	Replace the hydraulic pump.
	The pressure relieve valve (1,5-2,5 bar) for the charge pump defective.	Check the valve and its spring. See ""Charge pump" at page 6.
	Speed control cable loose or mowed.	Repair/adjust the speed control cable.
Bad driving forwards	Bad efficiency rear drive.	Replace the rear axle drive.
Bad driving backwards	Bad efficiency front drive.	Replace the front axle drive.

4.7 Auxiliary hydraulic

Warning! Hydraulic oil under pressure can be very dangerous if hoses, lines or other distribution parts are leaking. To avoid personal injuries, always wear protection gloves and protection goggles during works with the hydraulic system.

Warning! Before starting the motor, place the machine outdoors or install an extraction device for the exhaust fumes. Otherwise the personnel will be poisoned.

This section describes the trouble shooting procedures in absence of proper functions at the hydraulic assisted steering and implement lifter. It also describes the correction measures in each actual case. When following the trouble shooting table, it is provided that the following states are fulfilled:

- Parking brake not activated.
- A new filter installed
- Motor is running in full speed.
- The oil reservoir level shall be adjusted.
- The machine is warmed up during at least 10 minutes to a oil temperature of at least 50°C.

The pressure (about 35 bar) in the auxiliary hydraulic is divided between the implement lifter and the steering torque valve. If anyone of these gets more pressure, the other must get less. See the diagram.

The adjustment screw in the figure below is accessible after that the instrument covers are dismantled. See "Instrument covers" at page 10 in section "2 Chassis".

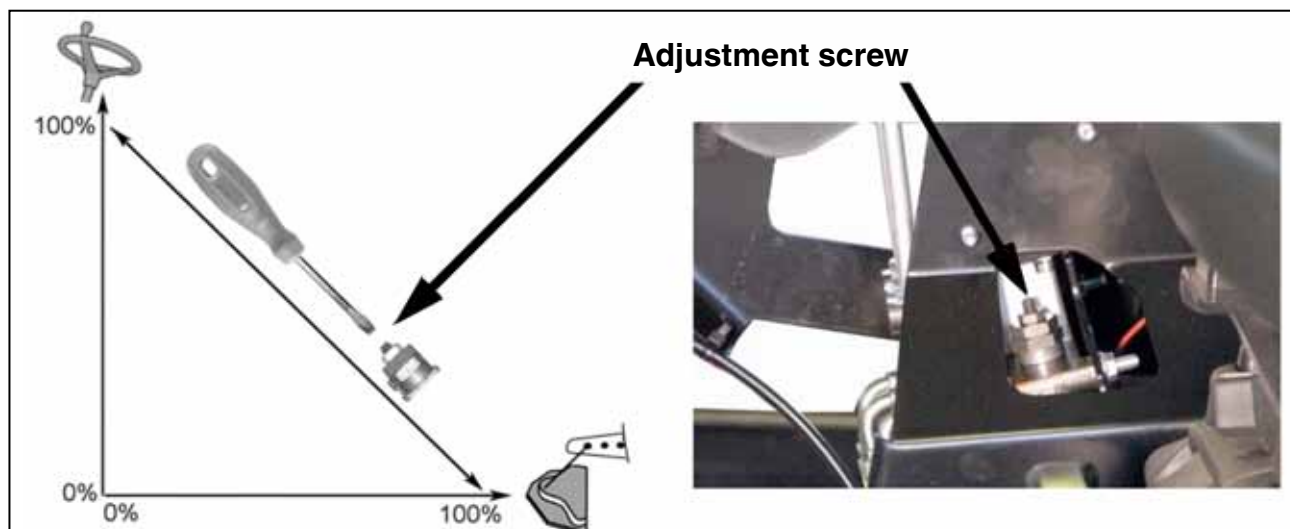

Adjustment



Warning! Never screw out the adjustment screw too far, this will cause lost of steering capacity.v

After adjustment; Always check the steering capacity with the implement lifter working against its stop.

Adjust the pressure (yellow line) by loosening the counter nut and rotate the adjustment screw. Turn right (against bottom) to increase the lifting capacity and to decrease the steering ability. Turn left (up) to decrease the lifting capacity and to increase the steering ability. Lock the counternut after the adjustment is finished.

Adjustment procedure

1. The lifting capacity is set to about 1500 N / 150 kg at the factory. Measure the force and adjust if necessary.

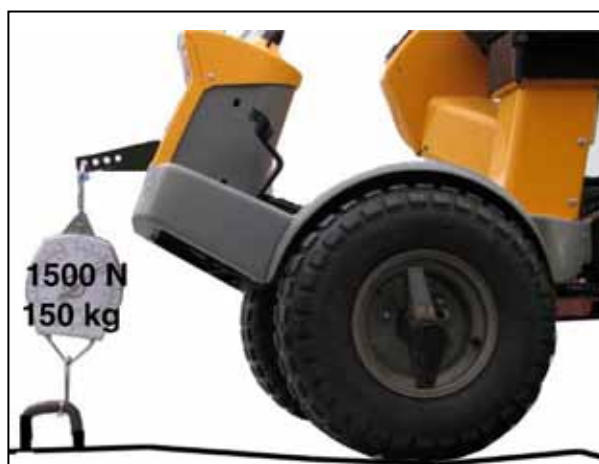

2. Drive the machine and test the steering ability.

If the steering is comfortable, the adjustment is OK.

If the steering not is comfortable, decrease the lifting ability.

If it is possible to reach an adjustment, where both the heaviest deck used can be lifted, and the steering feels comfortable, the adjustment is OK. If not, see below:

If the steering is comfortable when the screw is in its upper position and the lifting capacity is OK when the screw is in its lower position, replace the charge pump in the HST.

If the steering is impossible to get comfortable even when the screw is in its upper position and the lifting capacity is OK when the screw is in its lower position, replace the steering valve.

4.8 Change of transmission oil

The oil and the filter in the hydraulic power transmission must be checked/adjusted or replaced at intervals according to the table below.

Action	1.st time	Then at interval
	Hours of operation	
Check -adjusting level	-	50
Changing oil - Replace filter in the hydraulic circuit	5	200

Oil type: Synthetic oil 5W-50.

Oil volume at change: approx. 4.7 litres.

Check – adjustment

1. Place the machine on a flat surface.
2. Read off the oil level in the reservoir. See the figure. The level should be level with the line.
3. If necessary, top up with more oil.

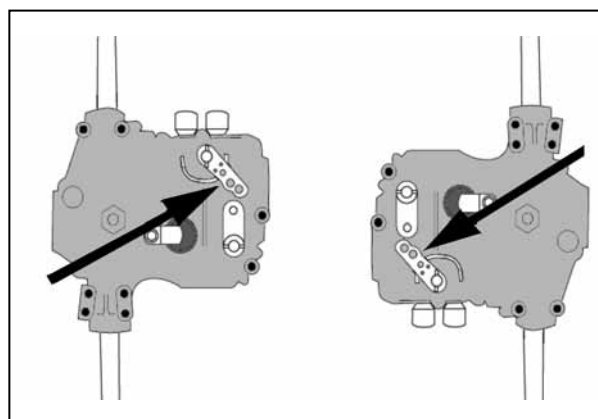
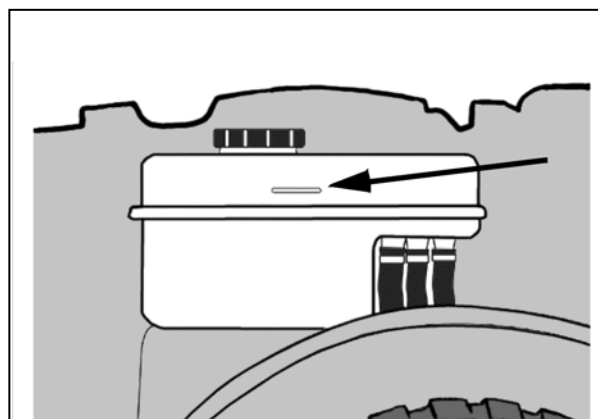

Draining

1. Operate the machine at varying speeds for 10-20 minutes in order to warm up the transmission oil.
2. Open the drive shafts' valves in accordance with the figure.
3. Place one collection trough under the rear axle and one under the front axle.
4. Remove 2 drainage plugs from each axle. Use a 12 mm socket wrench. See the figure.
5. Remove the filler cap from the oil tank.

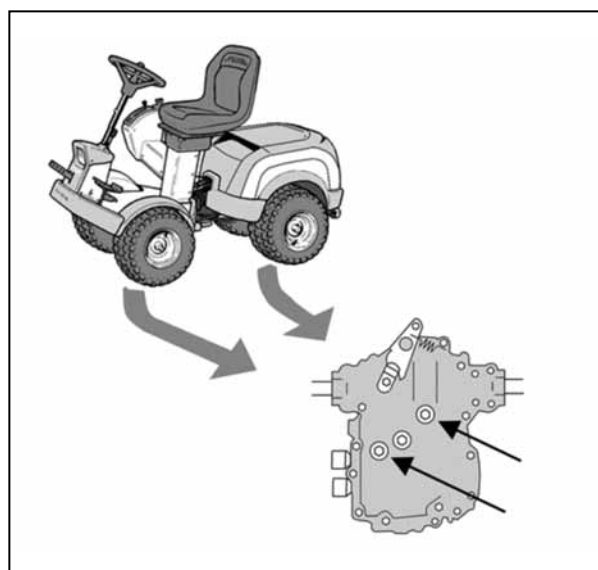

6. Clean the area around the hydraulic circuit's filter and dismantle the filter. See the figure.
7. Allow all the oil to run out into the collection trough.
8. Draw out the oil from the deeper section of the reservoir using an oil extractor. See the figure.
9. Hand in the oil for disposal in accordance with local provisions.

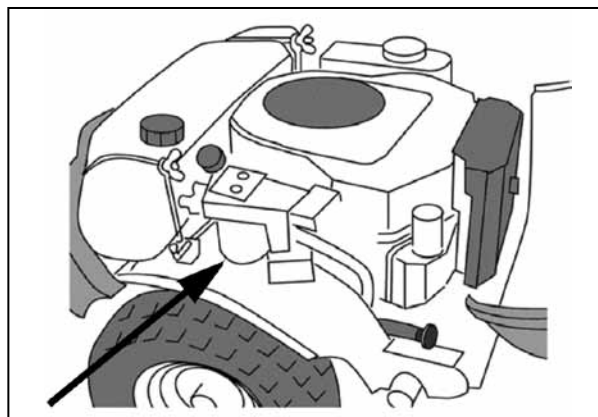

Filling with help of the engine

1. Check that the gaskets on the 4 drainage plugs are intact. Reinstall the plugs. Tightening torque: 15-17 Nm.
2. Moisten the new filter's gasket with oil and install the filter.
3. Fill the oil reservoir with the new oil.
4. Check that the clutch release lever (R) is in the outer position (drive position).



If the engine is to be run indoors, an exhaust extraction device must be connected to the engine's exhaust pipe.

5. Prepare a suitable vessel with the new oil.
NOTE! The oil is sucked into the system very quickly. The reservoir must always be kept topped up. Under no circumstances may air be sucked in.
6. Fill the oil reservoir with new oil
7. Start the engine and allow it to idle. Gradually top up the oil in the reservoir so that the level constantly reaches the mark.

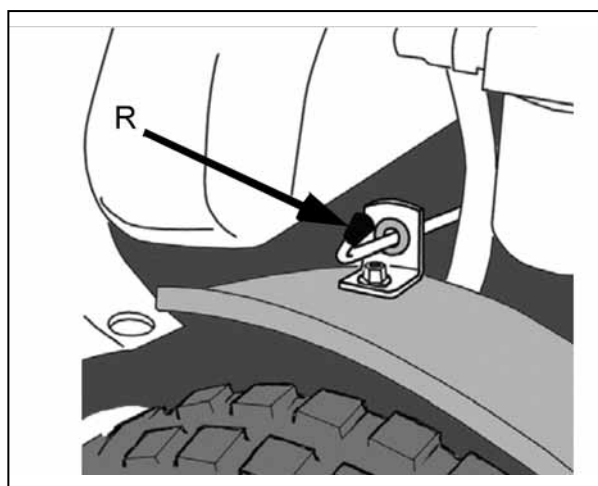
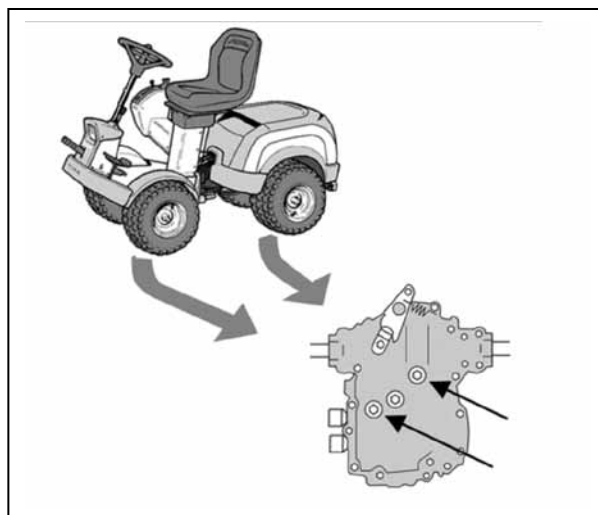

8. Reinstall the oil filler cap and close the engine casing.
9. Reset the drive shafts' valves in accordance with the figure.
10. Drive the machine 8-10 metres forwards and 8-10 metres backwards. Apply full steering in both directions at the same time.
11. If the machine has a hydraulic implement lifter, raise and lower the lifter 3-4 times.
12. Adjust the oil level in the reservoir.

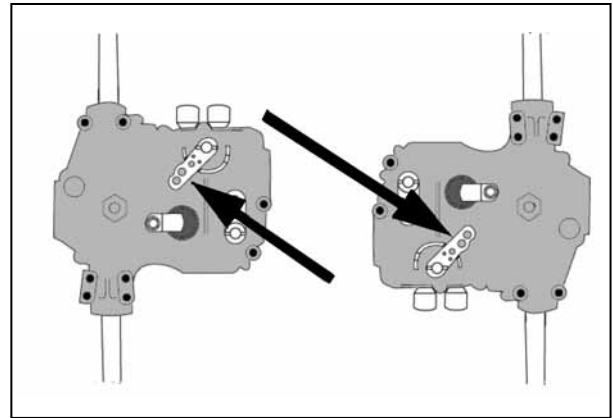

Filling with external pump

1. Check that the gaskets on the 4 drainage plugs are intact. Reinstall the plugs. Tightening torque: 15-17 Nm.
2. Moisten the new filter's gasket with oil and install the filter.
3. The drive shafts' valves shall be opened in accordance with the figure.

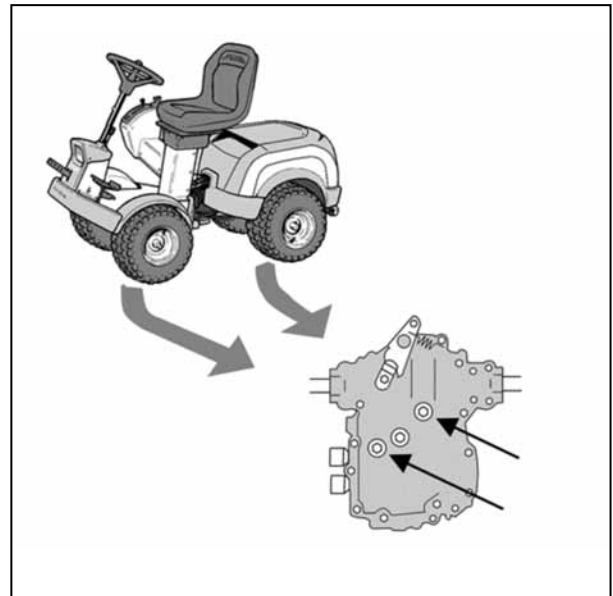

4. Check that the clutch release lever (R) is in the outer position (drive position).

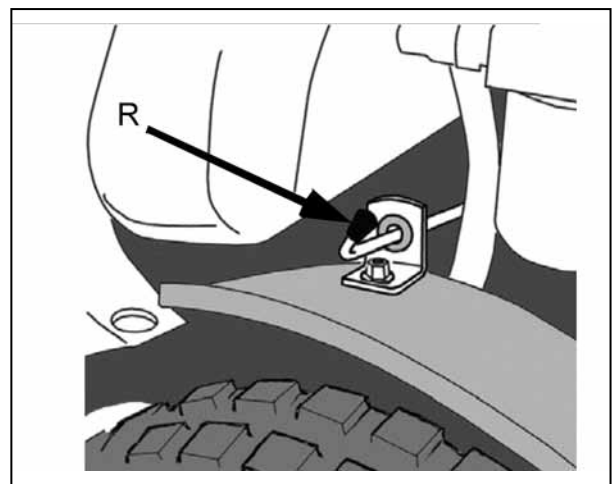

5. Connect a pump device to the nipple in the figure and pump in the new oil into the system.
6. Stop pumping when the oil reservoir is nearly full.
7. Start the engine and allow it to idle. Gradually top up the oil in the reservoir so that the level constantly reaches the mark.
8. Fill the oil reservoir with the new oil.
9. Check that the clutch release lever (R) is in the outer position (drive position).

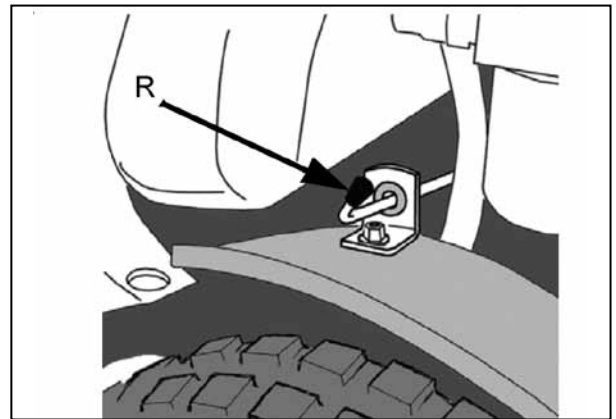

10. Reset the drive shafts' valves in accordance with the figure.
11. Drive the machine 8-10 metres forwards and 8-10 metres backwards. Apply full steering in both directions at the same time.
12. If the machine has a hydraulic implement lifter, raise and lower the lifter 3-4 times.
13. Adjust the oil level in the reservoir.

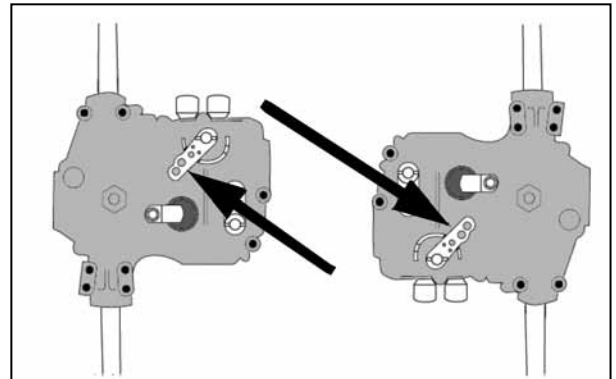

5 - Belts

Contents in this chapter

5.1 Belt theory	2
5.2 Belt locations	4
5.3 Replacement of belts	5
5.3.1 Belt A.....	5
5.3.2 Belt B.....	5
5.3.3 Belt C.....	5
5.3.4 Belt D.....	6

General

All mechanical power, delivered by the motor, is conducted to the different power consumers by a belt system. The maximum tension of each belt is regulated by a spring loaded belt tensioner.

This chapter gives a brief description of the belt system and describes briefly replacements of the belts.





5.1 Belt theory

The table below shows the demands on normal commercial grade belts compared to demands on original spare parts belts from the retail dealer. The later are designed and manufactured in close connection between the subcontractor and the rider manufacturer.

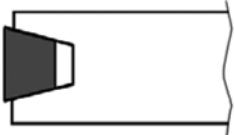
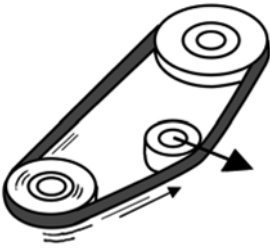
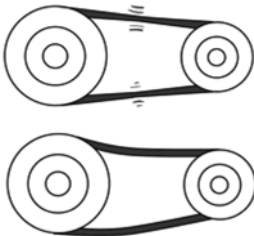
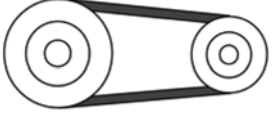
The table is intended to display the importance to use the original belts..

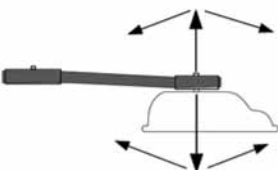
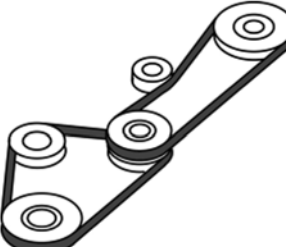
Case	Commercial grade belts	Original spare parts belts	Remarks
Fitness to pulleys. 	The belt shall rest with its angled sides against the pulleys. There must be a space between belt and pulley bottom.	The belt shall rest with its angled sides against the pulleys. There must be a space between belt and pulley bottom.	Same demands. Original belts guarantee that the belt fits against the pulleys.
Acceleration. 	The belt follows the motor rpm in a continuous acceleration up to full speed.	Some belts shall engage to the pulleys with the motor running in full speed, which gives an excessive generation of heat.	Common belts are made of natural rubber, which can resist temperatures up to 70° only. Original belts are made of chloroprene rubber, which can resist temperatures up to 90°
Length	Manufactured in standard lengths in steps 	Manufactured in predefined lengths to fit between the pulleys 	The distance between the pulleys is fix. The belt tensioner gives the original belt an optimal tension.

Case	Commercial grade belts	Original spare parts belts	Remarks
Floating pulley at the implement. 	Designed to transmit power between aligned, parallel and fixed pulleys.	The original PTO belt is designed to operate, even if the pulleys are moving up and down and are tilting at the same time	The implement follows the ground which involves that its pulley is constant moving. To resist the excessive operating conditions, the original belts are made of fibre reinforced rubber.
Bending in two directions 	Designed to bend around pulleys in one direction only	Most of the belts at the machine have tension rollers, actuating from the outside of the belt. This means the the belt has to bend both inwards and outwards during the operation.	All original belts which operate with tension rollers actuating from the outside have reinforcements. The reinforcement is special designed for the actual case.
Noise 	Manufactured without any special respect to the actual case.	The original belts are carefully selected to give the lowest noise increment to the machine during operation.	Depending on the function of the belt, any of the following belt types are itemised: <ul style="list-style-type: none"> • Wrapped • Non-friction • Raw-edge

5.2 Belt locations

1. Puleggia sull'attrezzatura di lavoro.
1. Pulley at the work equipment.
2. Tension pulley.
3. Pulley (double) above the front shaft.
4. Tension pulley.
5. Pulley (double) at the articulation point.
6. Tension pulley.
7. Drive pulleys at the motor shaft.
8. Tension pulley.
9. HST pulley. .

- A. PTO belt.
- B. Belt, articulation point - forwards.
- C. Belt, motor-articulation point.
- D. Belt, motor - HST.

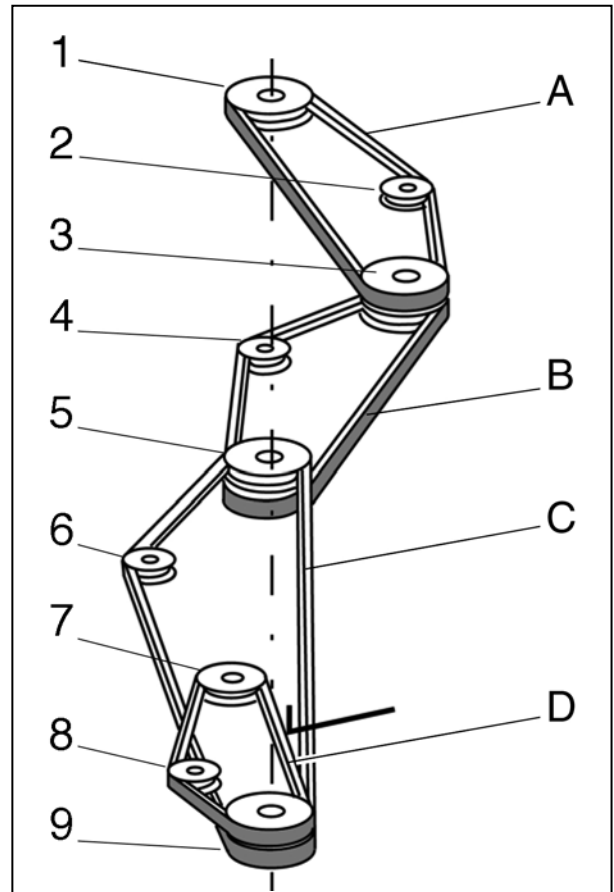

5.3 Replacement of belts

5.3.1 Belt A

Belt A belongs to the work equipment and is not described here. The description is included in the respective work equipment manual.

5.3.2 Belt B

1. Dismantle the tensioning arm with its pulley. See parts of the instruction in “Covers around the articulating point” at page 6 in section 2.
2. Work off the belt and assemble in the reverse order.

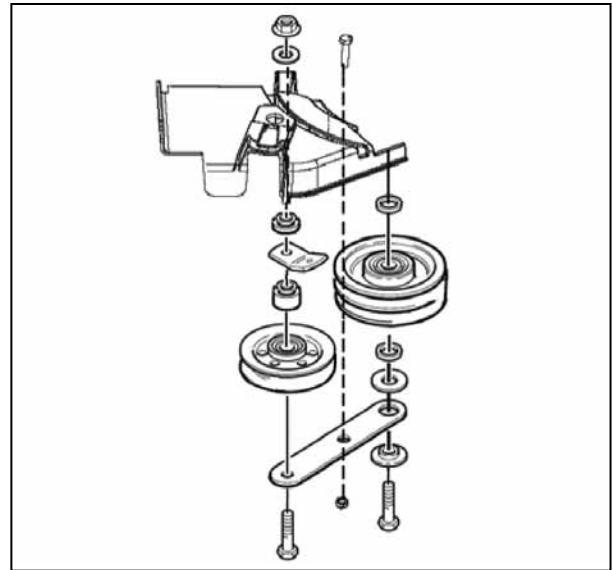

5.3.3 Belt C

1. Remove belt A and B. See above.
2. Remove the tension pulley by using a 15 mm and a 17 mm spanner. See the figure.
3. Remove the magnetic clutch cables.

Warning! The magnetic clutch is heavy. Be careful when removing.

4. Screw out the magnetic clutch screw and pull down the clutch.
5. Replace the belt and reassemble in the reverse order.

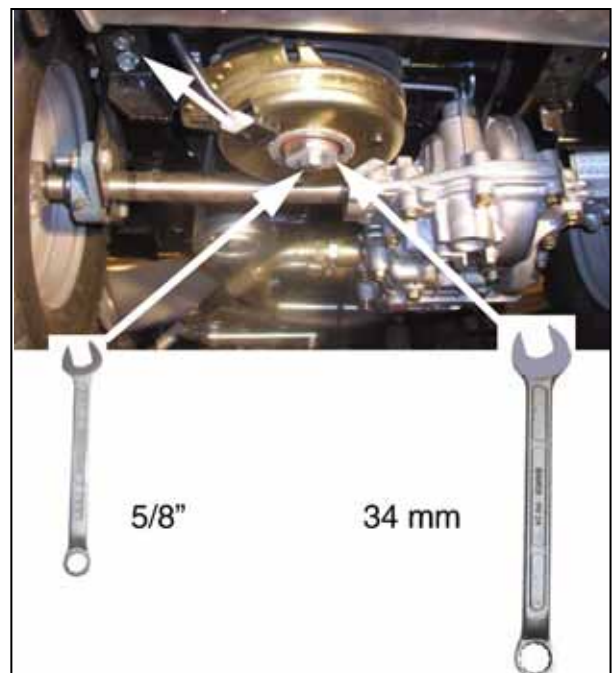

- ! **Note!** Check that the dog fits in the hole in the magnetic clutch. See the figure.

Tightening torque magnetic clutch screw: 50 Nm.



5.3.4 Belt D

1. Remove belt A, B and C. See above.

- ! **Warning!** Do not bend the lever when loosening or tightening the pulley nut.

2. Remove the tension pulley by using two 15 mm wrenches.
3. Replace the belt and reassemble in the reverse order.

- ! **Note!** The belt guide shall support the belt from its outside.

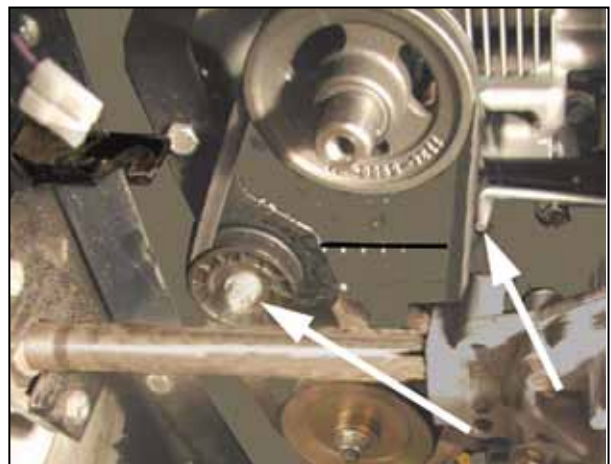

6 - Control Wires

Contents in this chapter

6.1 Description	2	6.4 Choke wire	7
6.2 General measures	3	6.4.1 Smontaggio	7
6.2.1 Elbow links.....	3	6.4.2 Assembly.....	8
6.3 Throttle wire	5	6.4.3 Adjustment	8
6.3.1 Dismantling.....	5	6.5 HST control wire	9
6.3.2 Assembly.....	6	6.5.1 Dismantling.....	9
6.3.3 Adjustment	6	6.5.2 Assembly.....	9
		6.5.3 Adjustment	10

General

All the manoeuvring functions are incorporated on the control panel. This is an excellent solution in terms of ergonomics and comfort. It also simplifies the service work since all the controls and adjustments can be accessed in one place.

All mechanical control movements from the operator to the respective device on the machine are conducted by wires and in some cases with rods.

This chapter gives a brief description of the equipments and describes their repair and replacements.



6.1 Description

All wires consist of a wire and a conduit. In the wire ends one part, the wire or the conduit, is fastened to the body and the other part to a lever. The levers are connected to the operator control and to the controlled device.

The wires are also in most cases fitted with adjustments sleeves with locking nuts or angle links at one or both ends.

To transfer higher forces and both pushing and traction forces, rods are used,

Maintenance of wires:

Drop a little engine oil or lubricating spray in the ends of the control wires two or three times a year..

- A. Rod
- B. Wire with conduit
- C. Fastening to body
- D. Lever
- E. Spring
- F. Elbow link

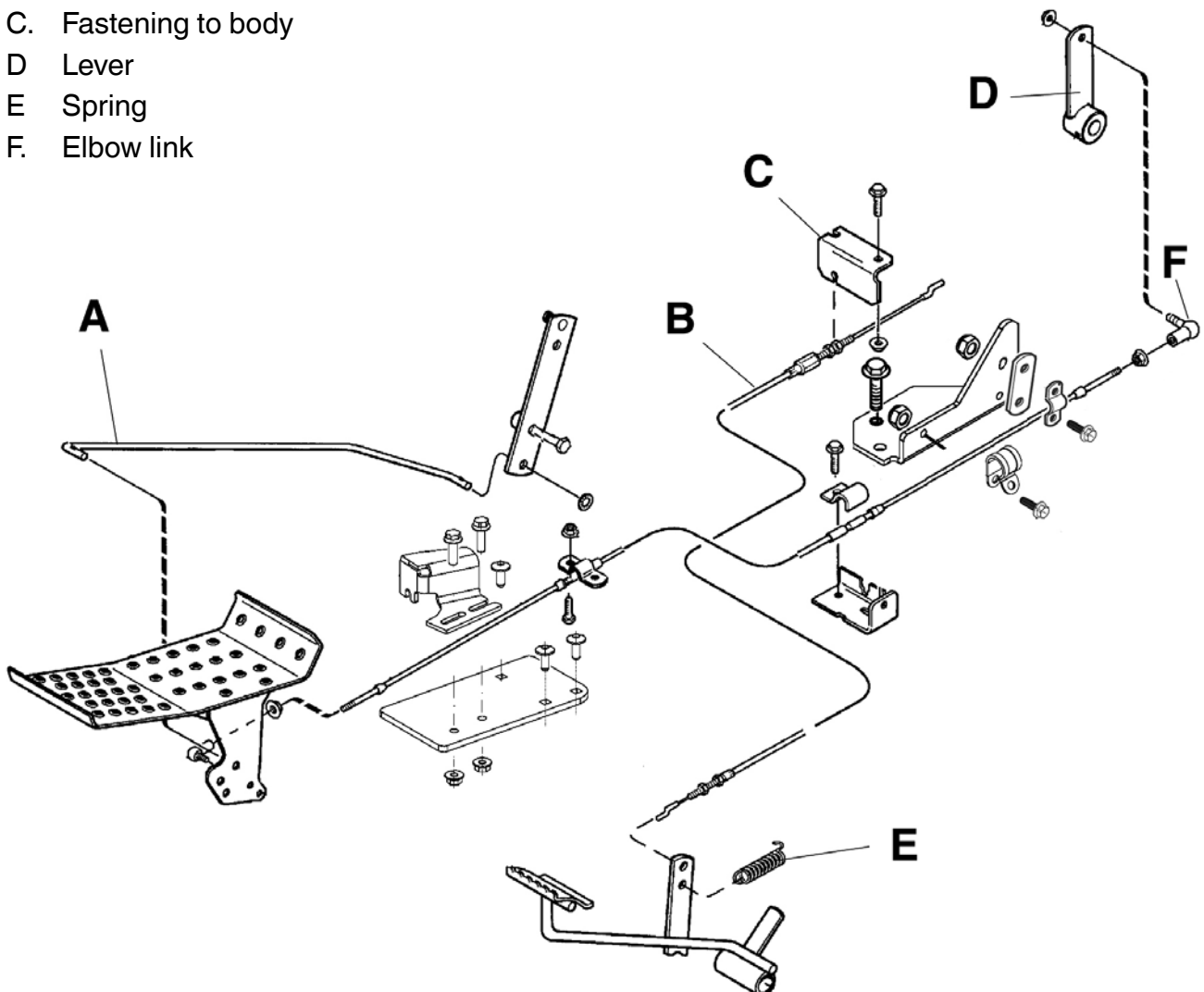

6.2 General measures

6.2.1 Elbow links

In many cases there are elbow links mounted at the wire ends. The elbow links have two functions as follows:

- To transmit the movement to/from the actual lever.
- For wire adjustment purpose. The wire tension is adjusted by screwing the link on/off the threaded rod at the wire.

! **Note!** At the adjustment, at least 5 threads shall be engaged.

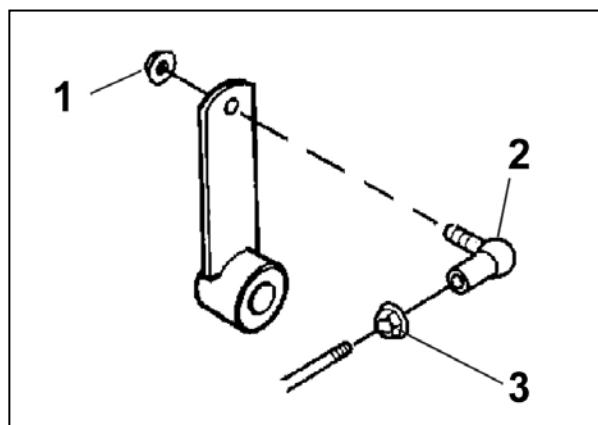

To change an elbow link

1. Loosen the nut (3) with a 8 mm wrench.
2. Remove the nut (1) with a 8 mm wrench. Hold the elbow stud with a 7 mm wrench.
3. Screw the elbow link off the rod.
4. The assembly is performed in the reverse order.
5. After the assembly, adjust the wire.



To apart an elbow link

1. Fold up the circlip (4) from the elbow link body.
2. Pull out the circlip.
3. Pry off the link body from the stud sphere by help of a screwdriver or similar.
4. The assembly is performed in the reverse order. The link body is pressed onto the sphere by help of a polygrip or similar.

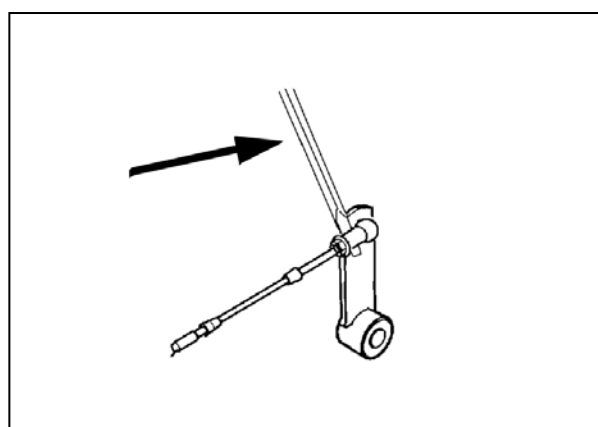

! **Note!** It is important that the circlip (4) is inserted in both holes in the elbow link body, otherwise the link will separate during operation.

Adjustment

1. Loosen the nut (3) with a 8 mm wrench.
2. Apart the elbow link as described above.
3. Screw the link body in the desired direction on the wire stud. If necessary, move the nut (3) on the stud.
4. Check the adjustment result by pressing on the elbow link onto the sphere and without assembling the circlip.
5. After adjustment, assemble in the reverse order and tighten the nut (3) against the elbow link body.

! **Nota!** It is important that the circlip (4) is inserted in both holes in the elbow link body, otherwise the link will separate during operation.

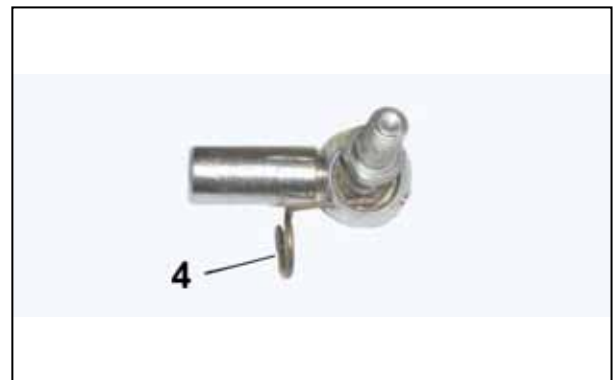
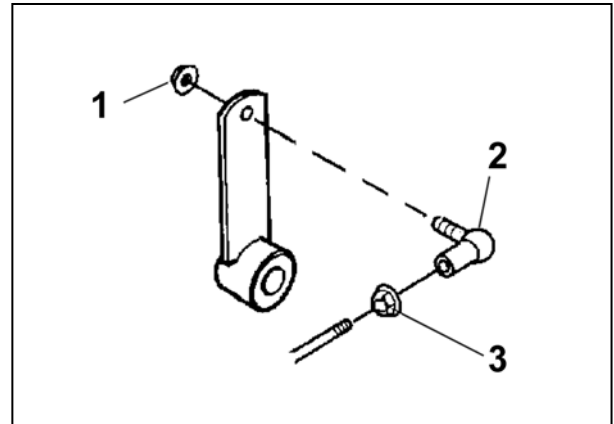

6.3 Throttle wire

6.3.1 Dismantling

1. Dismantle the upper and lower front engine covers. See “Front engine covers” at page 5 in “2 Chassis”.
2. Dismantle the outside instrument cover. See “Instrument covers” at page 10 in “2 Chassis”.
3. Cut the holding straps (A) and note their location for the assembly purpose.
4. Dismantle the lower instrument cover (B) by loosening its four screws.

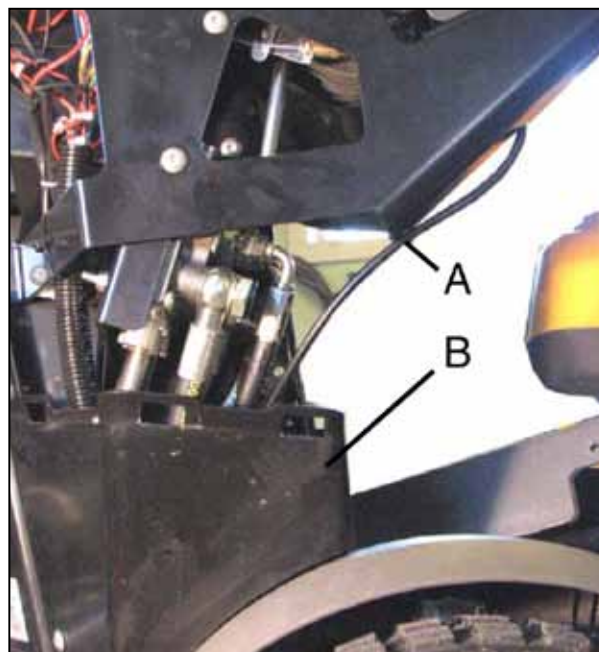

5. Loosen the nut at the rear of the engine and hook off the wire.



6. Push out the choke wire and the throttle wire from the holder at the articulating point.



7. Press out the front sleeve from its holder.
Use a screwdriver.
8. Work the entire wire forwards and hook it off the throttle lever and take it out.

6.3.2 Assembly

1. Assemble the throttle wire in the reverse order.
2. Drop a few drops oil at the wire ends and move the wire some strokes in its housing.
3. The front sleeve can be forced into place with help of a polygrip pliers.
4. Install new holding straps where the previous was cut.



6.3.3 Adjustment

1. Tighten the sleeve holding screw (A) very light.
2. Set the throttle lever in its idling position.
3. Start the engine and adjust the sleeve until the engine rpm shall start to increase.
4. Tighten the sleeve screw in a position where the engine rpm still is idling.



6.4 Choke wire

6.4.1 Smontaggio

1. Dismantle the upper and lower front engine covers. See “Front engine covers” at page 5 in “2 Chassis”.
2. Dismantle the outside instrument cover. See “Instrument covers” at page 10 in “2 Chassis”.
3. Cut the holding straps (A) and note their location for the assembly purpose.
4. Dismantle the lower instrument cover (B) by loosening its four screws.
5. Loosen the nut at the rear of the engine and hook off the wire.

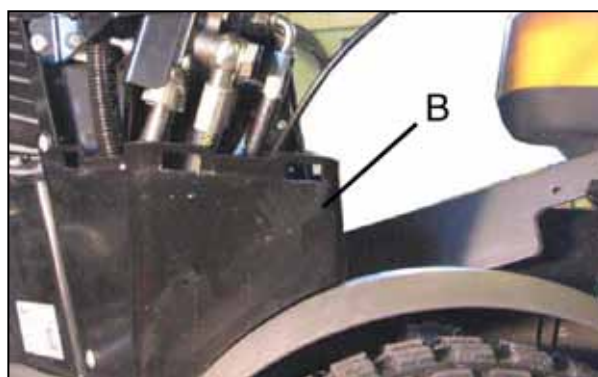

6. Push out the choke wire wire from the holder at the articulating point.



7. Loosen the knob nut, located under the panel.
8. Work the entire wire forwards and take it out through the panel mounting hole.

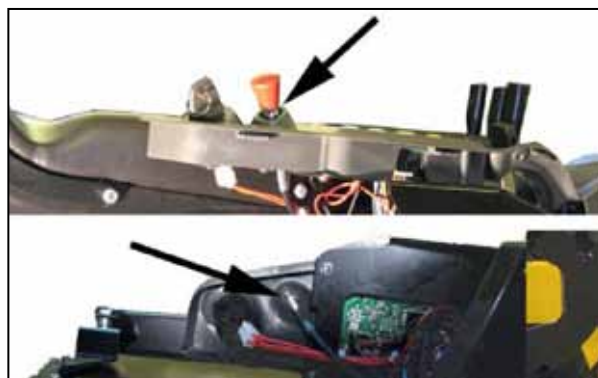

6.4.2 Assembly

1. Assemble the choke wire in the reverse order.
2. Drop a few drops oil at the wire ends and move the wire some strokes in its housing.
3. Install new holding straps where the previous was cut.

6.4.3 Adjustment

1. Tighten the sleeve holding screw (A) very light.
2. Actuate the choke knob and check that the engine choke lever can reach its end positions. Check also that the choke knob can be forced fully into its end down position.
3. Tighten the sleeve screw (A).



6.5 HST control wire

6.5.1 Dismantling

1. Dismantle the upper and lower front engine covers. See "Front engine covers" at page 5 in "2 Chassis".
2. Loosen the elbow links front and rear from their levers. See "Elbow links" at page 3.
3. To make it easier to take out the wire, unscrew the rear elbow link from the rod.
4. Loosen the conduit attachments front and rear and draw out the wire forwards.



6.5.2 Assembly

1. Fit the new wire in the same location as the old one.
2. Check the elbow links for damage or wear. Replace with new links if necessary. Fit the elbow links with their locking nuts at the wire ends. See "Elbow links" at page 3. The links shall be screwed onto the wire ends about 1 cm.
3. Fit the new wire.

! **Note!** The longer rod tube shall be located forwards.

IMPORTANT NOTE - For machines built after 2014 until November 2019, make sure all the latest updates for HST drive cable supports, illustrated in the figure, have been introduced, to eliminate any faults found in use. Should these updates not have been implemented, THEY MUST be performed using the specific kits and following the relevant assembly instructions.

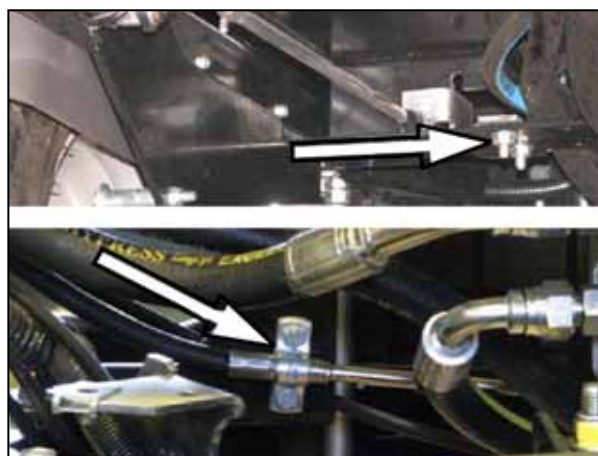

4. Fit the front and rear clamps. Make sure that the dogs at the clamps fit in the grooves in the wire cover. Both front and rear. See the figure.
5. Fit the elbow links to the levers.
6. Adjust the control wire as described below.

6.5.3 Adjustment

The length of the wire is adjusted by screwing the elbow links in the desired direction. Perform the adjustment at both links. The links shall be screwed onto the wire about the same amount. See "Elbow links" at page 3.

1. Set the rear stop screw in its lowest position.
2. Block up the pedal with a piece of wood or similar until the pedal rests against its rear stop. If the pedal doesn't reach its rear stop, adjust the elbow links.
3. Check that the pump lever has fully reach its stop position. If not, adjust the elbow links.
4. Block up the pedal with a piece of wood or similar until the pedal rests against its front stop. If the pedal doesn't reach its front stop, adjust the stop upwards.
5. Check that the pump lever has fully reach its stop position. If not, adjust the elbow links.

When the control wire is properly adjusted, the following conditions shall be fulfilled:

- Both elbow links shall be screwed onto the wire ends about the same amount.
- The pedal shall easily reach its rear stop (moved backwards). Simultaneously shall the pump lever reach its stop position.
- The pedal shall easily reach its front stop (moved forwards). Simultaneously shall the pump lever reach its stop position.



Warning! If the pump lever reach its stop and the pedal not, abnormal push/pull forces will occur in the wire. This will limit the wire durability.



7 - Electrical system

Contents in this chapter

7.1 Description	2	7.5.1 Battery replacement	14
7.2 Troubleshooting	3	7.6 Board replacement	15
7.3 Electronic board	6	7.7 Diagnostic Tool	16
7.3.1 Messages and information on the display	6	7.8 Set Zero Tilt	16
7.3.2 Electrical diagram Park PRO - Honda Engine.....	7	7.9 Check and replace the main power cord	17
7.4 Electrical safety check	8	7.9.1 Protection sheath assembly.....	17
7.4.1 Operation check	8	7.10 Replacement of microswitch and operator presence cable (OPC) ..	18
7.5 Hermetic battery maintenance	13		

General

The electrical system has two main duties, to maintain the machine safety and to make the different functions easy to handle.

The main part of this chapter consists of trouble shooting of the electrical system to isolate faults and to give information about corrective measures. The electrical system is also described. There are also given instructions about general repair and replacement procedures.

! **Note!** Faulty electrical cards must always be replaced without attempting to repair them or replace the individual components.

! **Note!** Many of the checks described in this chapter involve intervention on connectors CN1, CN2 and CN3; to reach them, remove the external dashboard casing.

* In this chapter, the indication "operator seated or (present)" means the operator is in the driving seat, whereas "without operator or (absent)" means the driving seat is not occupied.



7.1 Description

The machine has a single electrical wiring system (B) which is completely isolated to avoid wear and damage. The wiring is connected to the electronic card (A) by means of connectors.

The figure below shows the electrical wiring, the main electrical components and the safety circuits which work with microswitches.

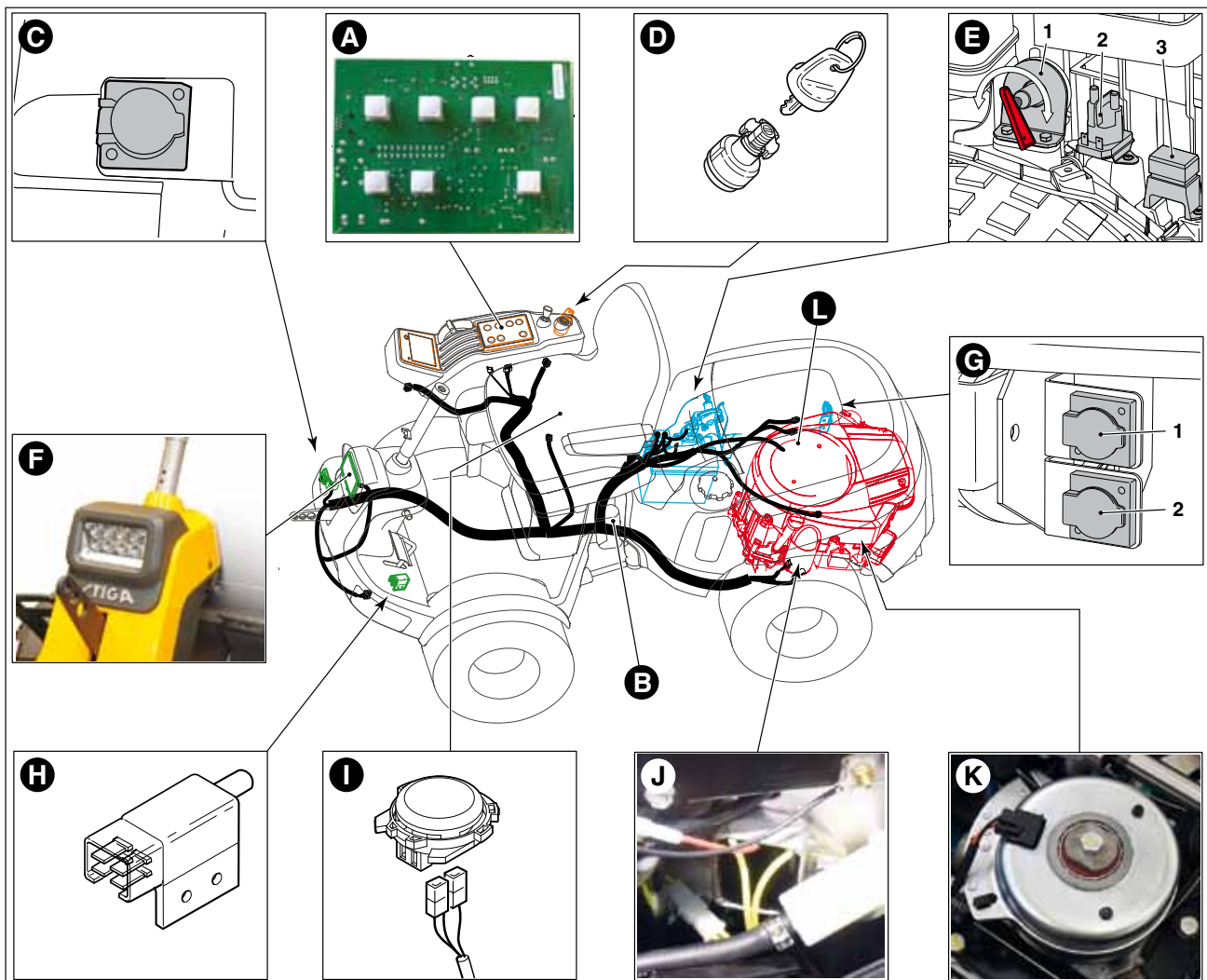

A. Electronic board.

B. Electric wiring.

C. Electrical socket for front accessory.

D. Key switch.

E. (1) Main ignition; (2) starting relay; (3) fuses.

F. Headlamp.

G. Rear sockets for accessory adjustment (1); (2) power supply.

H. Parking brake microswitch.

I. Safety switch.

J. Charge regulator.

K. Electromagnetic clutch.

L. Earth connected to the engine.

7.2 Troubleshooting

 **Warning! Never wear rings, metal bracelets, necklaces or similar metal objects when working on the electrical system. They could cause short circuits, burns and fires.**

This section describes troubleshooting procedures to be followed when there is an electrical fault in one of the machine functions. This section also describes which corrective action needs to be implemented to remove the fault. Should you need to apply the troubleshooting table, it is important the following conditions are met:

- All fuses must be checked and replaced if necessary.
- The battery has been charged.
- All wiring cables are OK.
- All connectors are OK.

 **Note!** In some cases, after a long period of use or in the event of mechanical damage, the cables which pass along the articulation may be damaged.

The actions to be taken are listed in order of most likely fault, consequently if the cause is not identified with the first check continue with the following ones. Continue through the list until the fault has been found.

Troubleshooting table		
Problem	Cause / Action	Remedy
1) With the key in the «ON» position the dashboard remains off.	The battery is not powering the card.	<ul style="list-style-type: none"> • Check the connecting cables. • Check battery conditions.
	No battery earth or electronic card connection.	<ul style="list-style-type: none"> • Check and restore. • Check the key of the main power switch.
	20 A fuse blown.	<ul style="list-style-type: none"> • Replace fuse (20 A).
	Battery polarity reversal.	<ul style="list-style-type: none"> • Check the connections.
2) The dashboard comes on but when the START button is pressed the starter motor does not turn or no power (uncertain start-up).	The battery is not providing enough current.	<ul style="list-style-type: none"> • Recharge the flat battery.
	Uncertain earth of battery or missing on start-up relay or motor.	<ul style="list-style-type: none"> • Check and restore.
	No start-up consent.	<ul style="list-style-type: none"> • Make sure the consent conditions are met. Check all the microswitches and relative wiring.
	Electronic card malfunction.	<ul style="list-style-type: none"> • Try replacing the electronic card with one you are sure works.
	Defect in the starting relay (you don't hear the click).	<ul style="list-style-type: none"> • Replace the starting relay.
	Starter motor fault (you hear the click).	<ul style="list-style-type: none"> • Replace the starter motor.

Troubleshooting table		
Problem	Cause / Action	Remedy
3) The starter motor turns but the engine does not start.	No fuel flow.	<ul style="list-style-type: none"> • Check the wiring of the carburettor solenoid valve opening command. • Check the fuel cock and filter.
	Insufficiency in the start-up system.	<ul style="list-style-type: none"> • Check the spark plug cap is securely in place. • Check the spark gap and that the electrodes are clean.
4) The starter motor stays on after engine start-up and is not disabled when the key is removed or the STOP button pressed.	Mechanical difficulties in the return of the mobile contacts on the starting relay.	<ul style="list-style-type: none"> • Replace the starting relay.
	Irregular operation of the starter motor due to mechanical or electrical problems which lead to greater absorption causing sticking of the relay contacts.	<ul style="list-style-type: none"> • Check the starter motor. Repair / replace.
5) The starter motor engages as soon as the key is in the «ON» position and can only be disabled by removing the key.	Faulty operation of the starting relay.	<ul style="list-style-type: none"> • Replace the starting relay.
	Faulty operation of the electronic card.	<ul style="list-style-type: none"> • Replace the electronic card.
	Faults with the buttons.	<ul style="list-style-type: none"> • Replace the control panel. • Replace the electronic card.
6) Incorrect operation of the electrical circuit (battery and electronic card).	Insufficient recharge.	<ul style="list-style-type: none"> • Check that the recharging lead is not disconnected and recharge the battery. • Check there is no dispersion caused by cables with damaged insulation and recharge the battery. • Check the recharging circuit.
	Overvoltage in recharging.	<ul style="list-style-type: none"> • Check the recharging circuit.
	Charge fuse blown.	<ul style="list-style-type: none"> • Replace the fuse (25 A) and check the charging circuit.
	The electronic card is damp.	<ul style="list-style-type: none"> • Dry the electronic card.
	Uncertain earth on the electronic card.	<ul style="list-style-type: none"> • Check and restore.
	Faulty electronic board.	<ul style="list-style-type: none"> • Replace the electronic board.

Troubleshooting table		
Problem	Cause / Action	Remedy
7) The engine stops during use.	Safety devices tripped or faulty.	<ul style="list-style-type: none"> • Check operation of the microswitches and relative wiring.
	Inadvertent disconnection of some electrical wire.	<ul style="list-style-type: none"> • Check all the wiring.
	No consent for engine running.	<ul style="list-style-type: none"> • Make sure that all consent conditions are met, check all the microswitches and relative wiring.
	Uncertain or no earth on the charge regulator.	<ul style="list-style-type: none"> • Check the earth connections and the regulator fixing screws.
	Overvoltage caused by regulator malfunction.	<ul style="list-style-type: none"> • Check the recharging circuit.
	Battery disconnected or faulty during use.	<ul style="list-style-type: none"> • Check the battery and the wiring.
8) The 20 A fuse has tripped.	Short circuit or overload on the power side of the electronic card (starter block, starting relay, headlamps and recharging connector).	<ul style="list-style-type: none"> • Find and replace the faulty user.
	Short circuit or damage to the electronic card protection system (power side).	<ul style="list-style-type: none"> • Try replacing the electronic card with one you are sure works. If the problem does not recur, permanently replace the electronic card.
	Short circuit on the front socket or on the rear sockets.	<ul style="list-style-type: none"> • Check the sockets.
	Fuse 20A blown.	<ul style="list-style-type: none"> • Replace the fuse.
9) Cutting deck height adjustment does not work.	It works in one direction.	<ul style="list-style-type: none"> • Replace the electronic board.
	It does not work in any direction.	<ul style="list-style-type: none"> • Check all contacts. • Check the cables. • Check the motor by connecting an additional battery to the power cable. • Replace the electronic board.
10) The clutch does not engage.	Power supply fault.	<ul style="list-style-type: none"> • Check the clutch cables and connections. • Replace the electronic board.
11) The sand spreader is not activated.	Power supply fault.	<ul style="list-style-type: none"> • Check cables and connections. • Replace the sand spreader motor.
12) The dashboard indicates that the operator is absent even if he is correctly seated	The OPC cable is damaged	<ul style="list-style-type: none"> • Replace the cable

7.3 Electronic board

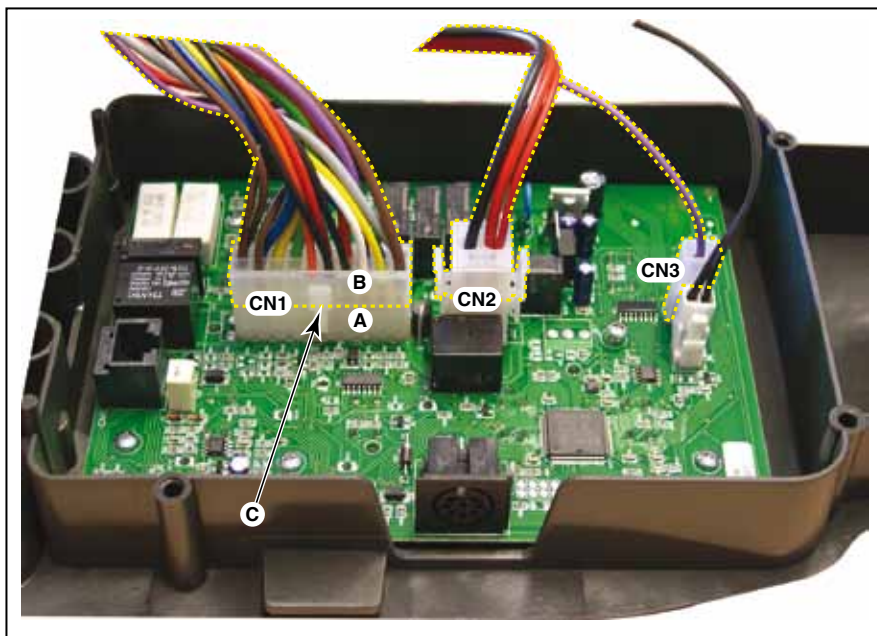

! **Note!** The electronic card is connected to the system by means of connectors CN1, CN2 and CN3.

The connectors are divided into two parts, the electronic card side and the wiring side.

E.g.: connector CN1 is divided into (A) for the electronic side and (B) for the wiring side.

The connector CN1 of the wiring is fitted with a lug (C) which locks it onto the female connector on the electronic card.

7.3.1 Messages and information on the display

Messages will appear on the machine display; the following information corresponds to each message string:

Message	Meaning
CHECK CONNECTION	When the sand spreader is enabled, a load with adequate consumption is not detected.
NO MOVING	When the height of the rear accessory is adjusted, a load with adequate consumption is not detected.
START ENGINE	The PTO was started with the engine turned off - Start the engine.
PRESS BRAKE	You are trying to start the engine without engaging the brake - Press the brake pedal.
SIT DOWN	You are trying to start the engine or enable the sand spreader without sitting in the operator seat - Sit down in the operator's seat.
TILT SAVED	(for the Support Service only) - indicates the end of the inclinometer calibration procedure.
TILT FAULT	Indicates a malfunction of the tilt sensor.

7.3.2 Electrical diagram Park PRO - Honda Engine

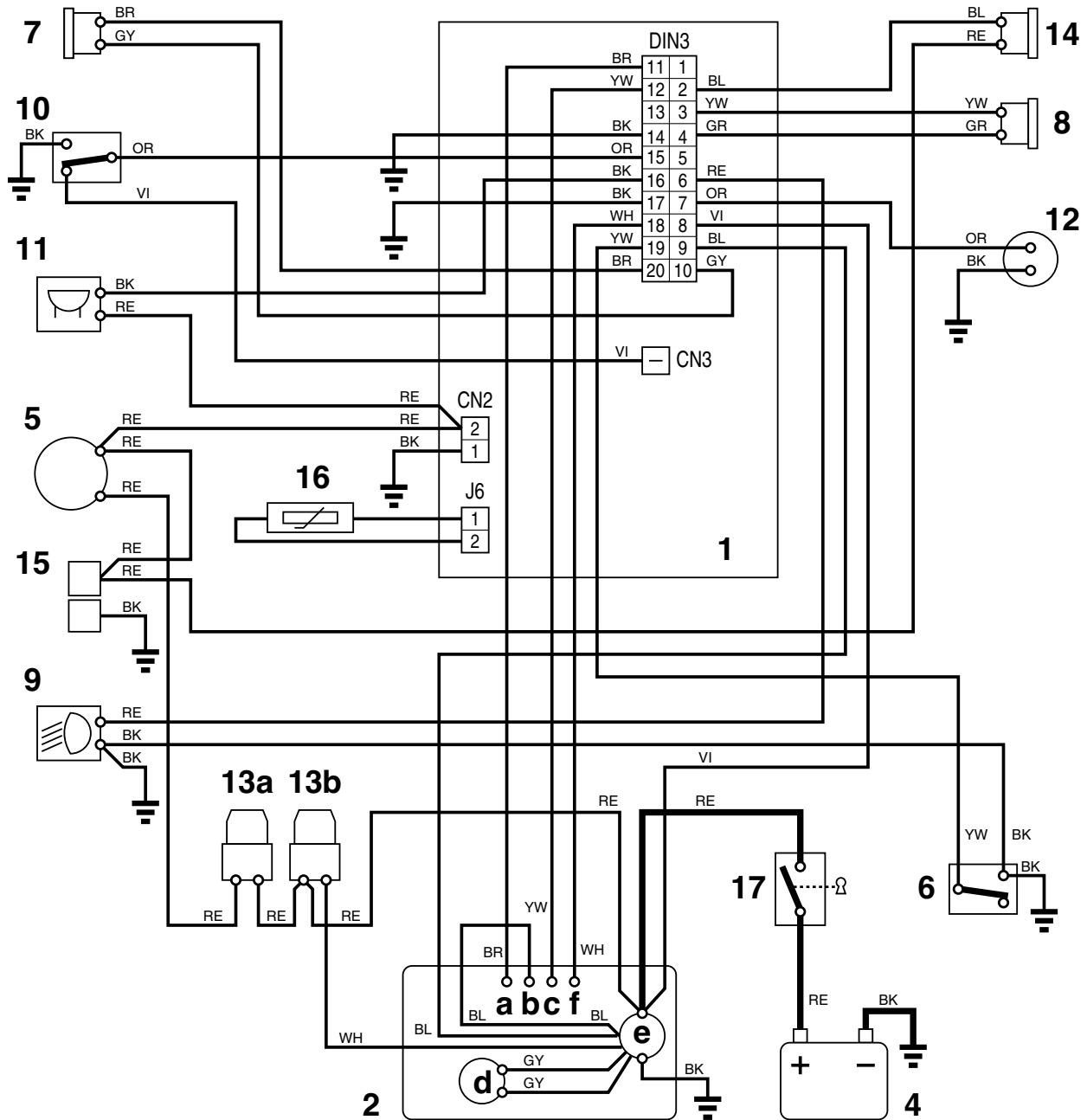

- 1 Electronic board.
- 2 Engine
- 2a Stop
- 2b Ignition
- 2c RPM counter
- 2d Generator
- 2e Starter
- 2f Oil sensor
- 4 Battery
- 5 Key ignition switch
- 6 Brake microswitch
- 7 Front accessories

- 8 Rear accessories
- 9 Headlight
- 10 Seat microswitch/Operator's presence
- 11 Horn
- 12 Clutch
- 13a 25 A fus
- 13b 20 A fuse
- 14 Sand spreader
- 15 Auxiliary accessories
- 16 Temperature sensor
- 17 Main key switch

CABLE COLOURS

- BK Black
- BL Blue
- BR Brown
- GR Green
- GY Grey
- OR Orange
- RE Red
- VI Violet
- WH White
- YW Yellow

7.4 Electrical safety check

Machine start is consented by the safety system if the following conditions are met.

- Parking brake engaged.
- Operator seated.

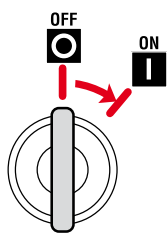

- Turn the ignition key to the ON position.



- Press START key.
- If all the aforementioned conditions are met, the engine starts.

In the following table you will find the interventions of the safety devices in the various situations of use.

A) Start-up

Driver	Parking brake	Engine	Cutting means	Result
Absent	Engaged	Off	Deactivated	It does not start.
Seated	Deactivated	Off	Deactivated	It does not start.
Seated	Engaged	Off	Deactivated	It starts

B) During mowing

Driver	Parking brake	Engine	Cutting means	Result
It lifts up.	Engaged	On	Deactivated	It stays on
It lifts up.	Deactivated	On	Deactivated	It switches off
It lifts up.	Deactivated	On	Engaged	It switches off
It lifts up.	Engaged	On	Engaged	It switches off

7.4.1 Operation check

Set-up for the check:

- Disconnect the connectors CN1, CN2 and CN3 of the wiring from the electronic card - To identify the connectors.
- Set the tester to the requested operating mode "ohmmeter" or "voltmeter"
- Make contact with the probes on the contacts of the wiring connector as described below.

Microswitches

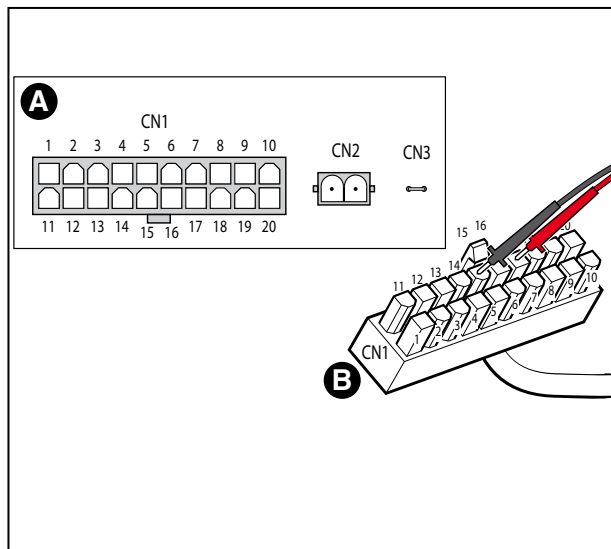

Set the tester in "ohmmeter" mode.

A Electronic board

B Wiring

The figure illustrates the check between the contacts 15 and 17 on the CN1 wiring connector.

	Contacts	Reading the Tester and situation	
Microswitch Seat	15-17 of the CN1	∞ (absent)	390 (+/-5%) ohm (seated)
	CN3 and 17 of the CN1	∞ (absent)	0 (seated)
Microswitch parking brake	17 - 19 of the CN1	∞ (free)	0 (engaged)

Key switch

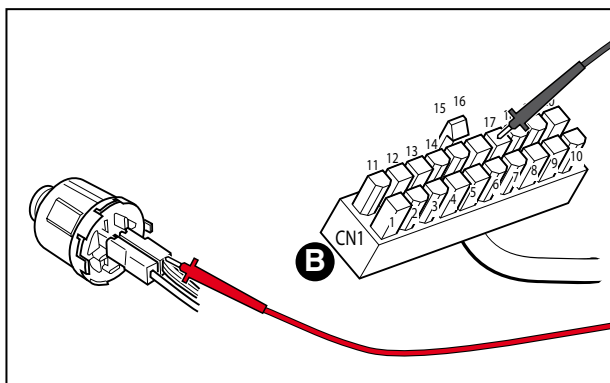

Set the tested in "voltmeter" mode (Volt DC0 - 20).

Disconnect the connectors CN1, CN2 and CN3 of the electronic board

	Contacts	Reading the Tester and situation	
Key switch	17 of the CN1 and connector 2 of the key switch	0 (OFF)	Battery voltage (ON)

Check terminal board power supply

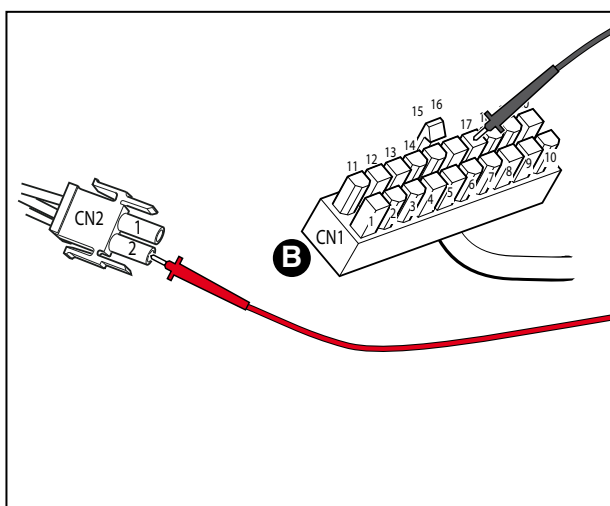

Set the tested in "voltmeter" mode (Volt DC0 - 20).

1. Disconnect the connectors CN1, CN2 and CN3 of the electronic board.
2. Rotate the switch key to pos. «ON».
3. With the black probe make contact on the 17 terminal of the CN1 connector.
4. With the red probe make contact on the 1 connector of the CN2 (connector with two red wires): on the display of the tester you should read the battery charge voltage.



Note! If the instrument fails to record any value, proceed to check the state of the battery.

Carburettor solenoid valve operation check

1. Connect the connectors CN1, CN2 and CN3.
2. Turn the key to the ON position.
3. Press START button.

Result:

- During start-up you should perceive the click of the carburettor solenoid valve coil.
- When turning off the engine the click of the solenoid valve coil should be more marked.

Check operation of the starting relay.

Warning! Disconnect the cap/s from the spark plug/s so that the safety systems which usually prevent any accidental engine start-up are excluded while the checking procedure is performed.

4. Apply the parking brake;
5. Turn the key to the ON position.
6. Disconnect connectors CN1, CN2 and CN3 from the electronic board.
7. Wiring side connector. Create a bridge between terminal 8 of the CN1 connector and terminal 2 of the CN2 connector (connector with two red wires).

Result:

You must perceive the click of the relay coil.

The starter motor starts.

- If the relay clicks but the starter motor does not start, make a bridge (A) with a large section cable (5 mm²) between the relay power contacts. If at this point the starter motor turns, look for the fault inside the relay or replace it.

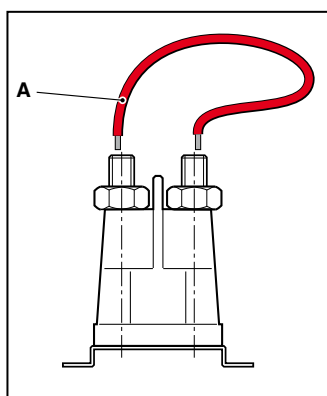

- If the starter motor still does not start, check the motor and relative wiring.

Check operation of the electrical sockets

- Set the tester to voltmeter mode (Volt DC 0 - 20).

	Key switch in position	Operator	Action	Result
Front electrical socket	ON	(Absent)	<ul style="list-style-type: none"> • Insert the probes in the front socket. 	On the tester display you will see the value referring to battery voltage with the symbol + or - (if necessary reverse the position of the probes to read the correct positive value).
Rear electrical socket	ON	(Present)	<ul style="list-style-type: none"> • Insert the probes in the rear socket. • Press the rear accessory regulation control. 	On the tester display you will see the value referring to the battery voltage with the symbol + or - (if necessary reverse the position of the tips to read the correct positive value).
Rear auxiliary electrical socket	ON	(Absent)	<ul style="list-style-type: none"> • Insert the probes in the rear auxiliary socket 	On the tester display you will see the value referring to the battery voltage with the symbol + or - (if necessary reverse the position of the tips to read the correct positive value).

Check operation of the electromagnetic clutch



This check must be performed when the engine is stationary.

1. Disconnect the connectors CN1, CN2 and CN3 on the electronic board.
2. Wiring side connectors Connect the probes to connector 7 of the CN1 and to connector 2 of the CN2 (connector with the two red wires).
3. Turn the key to the "ON" position.
4. Press the power take-off button (activates the front accessory).
 - When activating the power take-off, you should note the click of the mobile part of the clutch caused by excitation of the electrical winding. If this does not happen, check the wiring and operation of the command button.
 - If after these checks the clutch does not engage it must be replaced.

Recharging circuit check

The charge regulator, located on the engine, is designed to provide the battery with a current flow at a constant voltage of approximately 14 - 15 Volt, intervening each time the generator output voltage exceeds this threshold to take it back down to the correct value.

A faulty regulator may insufficiently charge the battery (requiring frequent recharging interventions) or, on the contrary, provide overvoltage which leads to the machine being switched off to safeguard the electronics and the battery.

Before checking the charging circuit, make sure that:

- The connections on the charging circuit are correct (see the electrical diagram);
- The earth (on the engine block) offers safe connection, also check the earth connection of the charge regulator:

- The battery is charged and not sulfated.
- The 25A charge fuse is intact.

A) Check the minimum charge threshold

- Set the tester to voltmeter mode (Volt DC 0 - 20).
 1. Start the engine and keep it at idle rpm.
 2. Turn on the headlamps.
 3. Measure the voltage on the battery terminals.v
 - If the value tends to drop, even slowly, it means that the regulator is not charging sufficiently and needs replacing.
 - If the voltmeter is not giving any reading ,it means that the charge fuse has blown.

B) Check the maximum charge threshold

- Set the tester to voltmeter mode (Volt DC 0 - 20).
 1. Start the engine and take it up to maximum speed.
 2. Measure the voltage on the battery terminals: the value should increase slowly until it stops at 15-15 Volts.

! **Note!** If the value of 14-15 Volts is exceeded until the engine stops due to intervention of a safety device (at around 16.8 Volts), it means that the regulator is charging too much and needs replacing.

C) Intervention values

- Max current values for the Sand spreader: 6A
- Battery “on” threshold: $12 \pm 0.2V$
- Battery “off” threshold: $12.8 \pm 0.2V$
- Warning threshold for extravoltage: $16 \pm 0.5V$
- Intervention threshold for extravoltage: $16.8 \pm 0.5V$

7.5 Hermetic battery maintenance

A) General information

In recombination hermetic batteries, the electrolyte of each element is accurately dosed in the production stage and sealed at source in order to guarantee maximum efficiency throughout the battery's life cycle.



Warning! There is no need to add water or acid to this type of battery and it must never be opened nor the cover removed.

B) Recommendations for correct use

To maintain battery efficiency and increase its duration, certain precautions should be taken:

- Always keep the battery in a good state of charge.
- Always fully charge a flat battery within 1 month, otherwise it may get damaged and no longer be rechargeable (sulfation).
- Always charge the battery before and after a prolonged period of inactivity or storage.



Charge using a constant voltage battery charger only. The use of any other type of battery charger could damage the battery.

C) Rules for battery charging

The charging operation is particularly important for the duration of the battery and must be carried out in accordance with these prescriptions:

- Do not charge batteries if the casing is broken or cracked;
- Carefully read the user instructions provided with the battery charger and battery;
- Use a suitable battery charger;
- Charge in an environment with an ambient temperature of between +10°C and +30°C.



Warning! When charging, make sure that the battery does not heat up to over 50°C; if this happens stop charging immediately and replace the battery as it is unusable.

With the battery disconnected (and unused for at least 12 hours) and the tester in voltmeter mode, measure the voltage between the poles; the value detected (open circuit voltage) provides an indication of the operations to be carried out as indicated in the table below:

Open circuit battery voltage	Battery status	Operation to be performed
13.1 Volt	Max. threshold	None
12.6 Volt	Min. threshold	None
< 12.4 Volt	Flat	Recharge



Note! Check the battery voltage after at least 12-24 hours following charging.

7.5.1 Battery replacement

The battery is located under the engine casing on the right-hand side. To reach it follow the instructions.

Disassembly

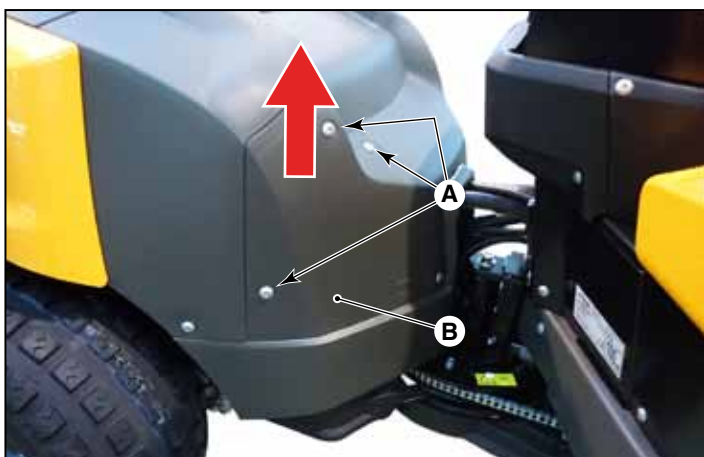

1. Tilt the seat forward.
2. Undo the 3 screws (A).
3. Lift and remove the casing (B).

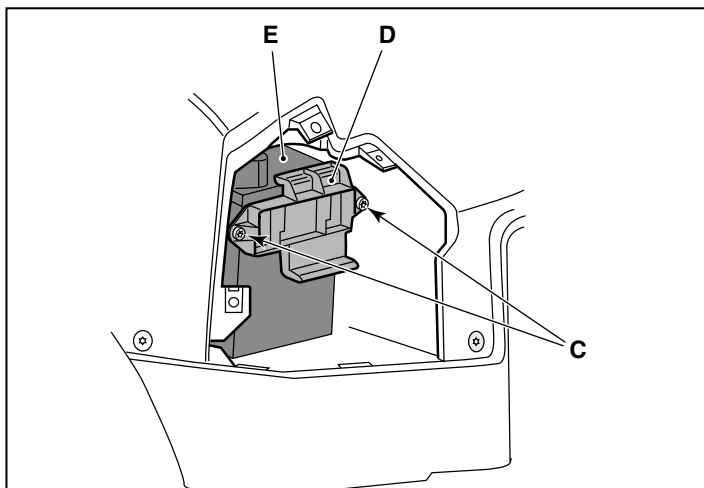

4. Unscrew the 2 screws (C) to remove the battery stopper (D)-
5. Take the battery out (E).

Reassembly

To reassemble the various parts, repeat the operations in reverse order.

7.6 Board replacement

Warning! Never wear rings, metal bracelets, necklaces or similar metal objects when working on the electrical system. They could cause short circuits, burns and fires.

Disassembly

- Remove the dashboard.

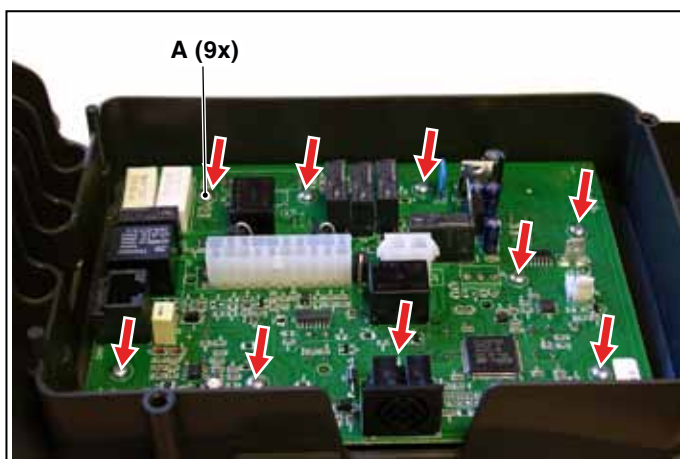

- Unscrew the screws (A) which fasten the board in place.
- Take the card from the dashboard mask.

Reassembly

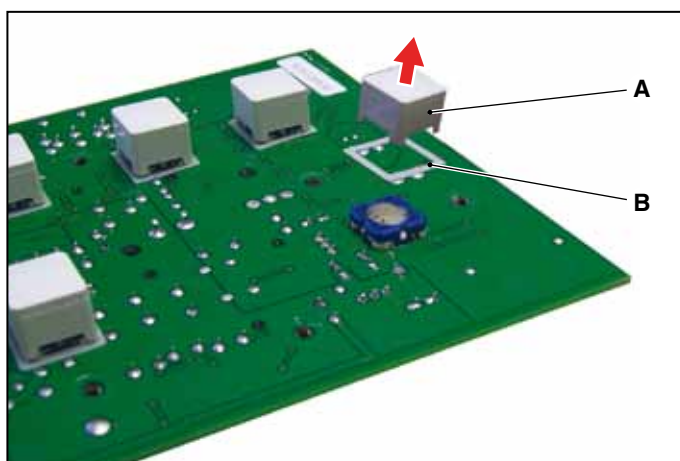

Note! On the rear of the card, in relation to each command, the following components are installed (A = button) and (B=gasket), take care not to damage them.

- Carefully remove the buttons (A) and the gaskets (B) one at a time and transfer them to the new card.
 - Assemble all the parts in reverse order and take special care over the button gaskets.
- Once reassembly has been completed, check all the functions.

7.7 Diagnostic Tool

The machine is fitted with an 8-pole connector (A) for connection to the Diagnostic Tool. This device together with the programmer (B) code 1134-9185-01, can perform the following functions:



1. Software updates of the electronic cards;
2. Diagnostics section to perform display testing and to check the keypad and control seat switch;
3. Access to data recorded on the electronic board (service hours, number of engine start-ups, number of battery warnings, max. revs reached by the engine, hours of use on slopes exceeding 10°, etc.);
4. Transfer of data recorded on one electronic card to another (useful when the electronic card has to be replaced).

For further information see:

<https://stiga.ev-portal.com/LogIn/Stiga>

<http://www.gggpartsandservice.com> ==> Service ==> Software ==> STIGA - Diagnostic Tool

7.8 Set Zero Tilt



Push the button "HIGH GRASS DOWN" and "REAR RAKE UP" together, after urn ON the key and after 5 seconds in the display it will appear the message "TILT SAVED".

7.9 Check and replace the main power cord



IMPORTANT - For work on the electrical system and battery, carefully check that the positive wires (red) are integral, that the insulation is not cracked or worn and that the corrugated protection sheath is installed and correctly mounted to prevent cables from being crushed by the battery housing after installation.

For machines prior to 2020 or, in any case, without corrugated protection sheath, this must be installed following the instructions hereto.

7.9.1 Protection sheath assembly

Needed Material:

- a) Open corrugated sheath \varnothing 10mm - length 150mm
- b) Duct tape
- c) Cable tie

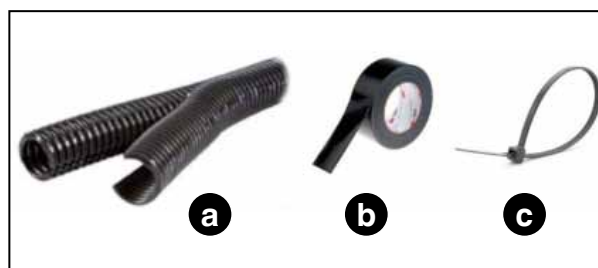

1. After having removed the fuel tank and battery housing, wrap the 2 red wires with the open corrugated sheath.



2. Secure the lower end of the corrugated sheath to the main harness with duct tape.



3. Place the main electric harness as closely as possible to the mudguard and pull the exceeding harness backwards as shown in the picture. This will avoid any possible contact with the battery case once mounted.



4. Secure the electric harness underneath the battery area by fastening the harness to the main frame bracket with a cable tie.



5. Rebuild the machine in reverse order.

7.10 Replacement of microswitch and operator presence cable (OPC)

1. Undo the two screws (1) and the two pins (2) to allow the seat (3) to be tilted and removed.

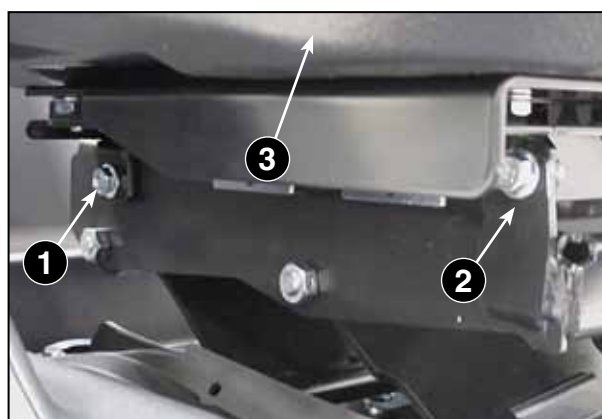

2. Disconnect the connector (4).



3. Undo the four screws (5) and remove the sliding plate (6).

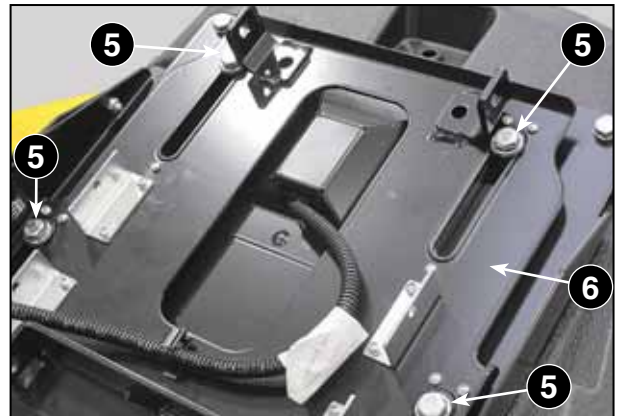

4. Undo the four screws (7) and remove the plate (8) taking care to extract the cable (9) without damaging it.

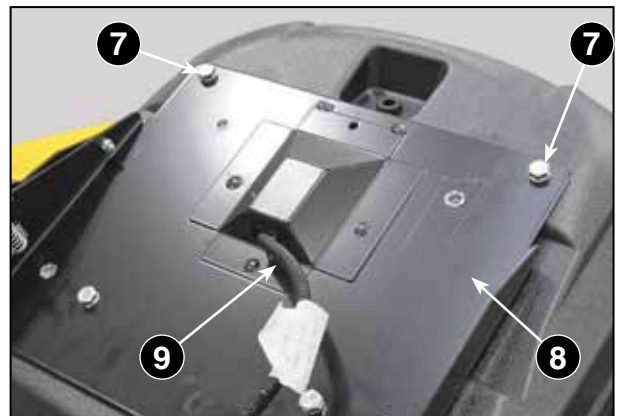

5. Use a screwdriver to release the connector (10).



6. Turn the switch (11) anticlockwise to extract it from its seat (12).

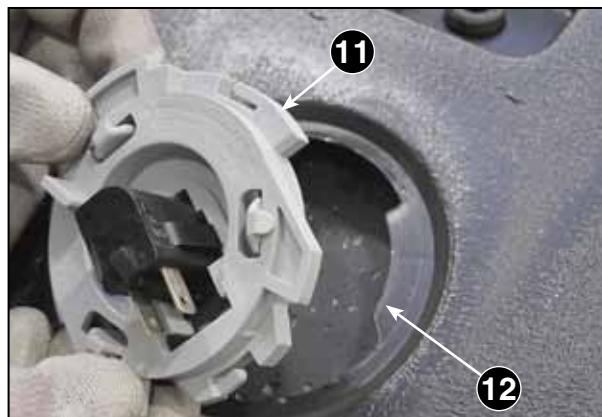

When assembling, perform the steps described above in reverse order.



WARNING! The screws (1) preventing the tilting of the seat are an important safety element for the operator and must therefore always be refitted after any work requiring their removal.



STIGA

STIGA S.p.A - Via del Lavoro, 6 - 31033 Castelfranco Veneto (TV) - Italy
www.stiga.com